

### Features

- Single Device: +5V Input
- Complimentary Dual Output:  $\pm 12V$ ,  $\pm 15V$
- Wide Input Voltage Range
- 85% Efficiency
- Adjustable Output Voltage
- Laser-trimmed

### Description

The PT5060 series of dual-output Integrated Switching Regulators (ISRs) provide a complimentary  $\pm 12V$  or  $\pm 15V$  from a single +5V input. Applications include systems that require power for analog interface circuitry, such as D/A and A/D converters, and Op Amps. The output voltage can be adjusted with an external resistor. These ISRs are made available in a 12-pin single in-line pin (SIP) package. Note that these modules are not short-circuit protected.

### Standard Application

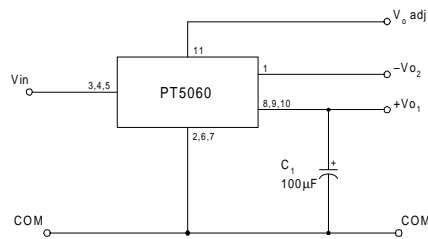

$C_1$  = Required 100µF electrolytic

### Pin-Out Information

Pin	Function
1	$-V_{O2}$
2	GND
3	$V_{in}$
4	$V_{in}$
5	$V_{in}$
6	GND
7	GND
8	$+V_{O1}$
9	$+V_{O1}$
10	$+V_{O1}$
11	$V_o$ Adj
12	Do Not Connect

### Ordering Information

PT5061□ =  $\pm 12$  Volts  
 PT5062□ =  $\pm 15$  Volts

### PT Series Suffix (PT1234 x)

Case/Pin Configuration	Order Suffix	Package Code *
Vertical	<b>N</b>	(ECD)
Horizontal	<b>A</b>	(ECA)
SMD	<b>C</b>	(ECC)
Vertical, Side Tabs	<b>R</b>	(ECE)
Horizontal, Side Tabs	<b>G</b>	(ECG)
SMD, Side Tabs	<b>B</b>	(ECK)

\* Previously known as package style 300.  
 (Reference the applicable package code drawing for the dimensions and PC board layout)

### Specifications (Unless otherwise stated, $T_a = 25^\circ C$ , $V_{in} = +5V$ , $I_o = I_{o,max}$ , $C_1 = 100\mu F$ )

Characteristics	Symbol	Conditions	PT5060 SERIES			Units	
			Min	Typ	Max		
Output Current	$I_o$	Over $V_{in}$ range	$V_{O1} = +12V$ $V_{O2} = -12V$	0.05 0.05 (1)	— —	0.50 0.25	A
Current Limit	$I_{lim}$			—	150 (2)	—	% $I_{o,max}$
Inrush Current	$I_{ir}$	On start up		—	5.5 (3)	—	A
	$t_{tr}$			—	2	—	mSec
Input Voltage Range	$V_{in}$	Over $I_o$ range		4.75	—	$+V_o - 1$	V
Output Voltage Tolerance	$\Delta V_o$	Over $V_{in}$ and $I_o$ ranges $T_a = 0^\circ C$ to SOA limit (3)	$+V_{O1}$ $-V_{O2}$	— —	$\pm 1.5$ $\pm 5$	$\pm 3.0$ $\pm 10$	% $V_o$
Line Regulation	$Reg_{line}$	Over $V_{in}$ range		—	$\pm 0.5$	$\pm 1.0$	% $V_o$
Load Regulation	$Reg_{load}$	$0.1 \leq I_o \leq I_{o,max}$		—	$\pm 0.5$	$\pm 1.0$	% $V_o$
$V_o$ Ripple (pk-pk)	$V_n$	20MHz bandwidth	$+V_{O1}$ $-V_{O2}$	— —	$\pm 1.5$ $\pm 2$	$\pm 3$ $\pm 3$	% $V_o$
Transient Response	$t_{tr}$ $V_{os}$	25% load change $V_o$ over/undershoot		— —	100 3	— 5	$\mu$ Sec % $V_o$
Efficiency	$\eta$	$I_o = 0.2A$ each output		—	85	—	%
Switching Frequency	$f_s$	Over $V_{in}$ and $I_o$ ranges		—	650	—	kHz
Operating Temperature Range	$T_a$	—		0	—	$+85$ (4)	$^\circ C$
Storage Temperature	$T_s$	—		-40	—	$+125$	$^\circ C$
Mechanical Shock		Per Mil-STD-883D, Method 2002.3, 1 msec, Half Sine, mounted to a fixture	—	500	—	G's	
Mechanical Vibration		Per Mil-STD-883D, Method 2007.2 20-2000 Hz, Soldered in a PC board	—	15	—	G's	
Weight				—	6.5	—	grams

- Notes:**
- (1) Do not operate the negative output rail of these ISRs below the minimum load.
  - (2) ISRs based on a boost topology are not short-circuit protected.
  - (3) The inrush current stated is above the normal input current for the associated output load.
  - (4) See Safe Operating Area curves or consult the factory for the appropriate derating.

**PT5061 +/- 12VDC** (See Note A)

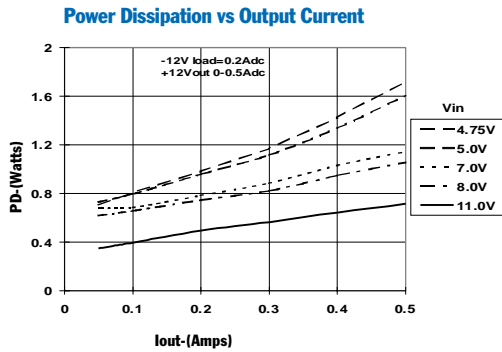
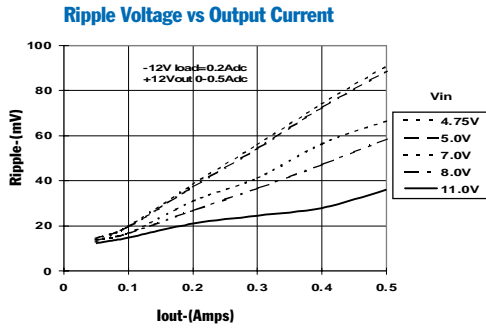
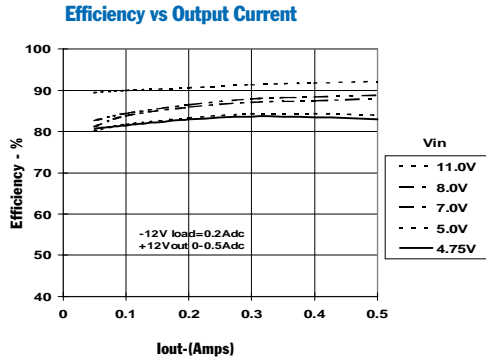

**Safe Operating Area,  $V_{in} = 5.0V$ ;  $I_{o2} = 0.25A$**  (See Note B)

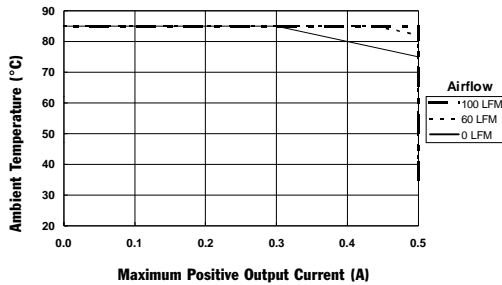

**PT5062 +/- 15V** (See Note A)

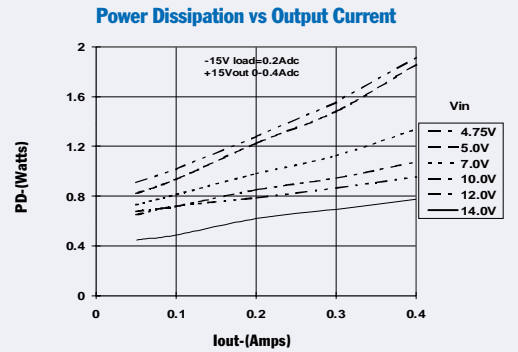
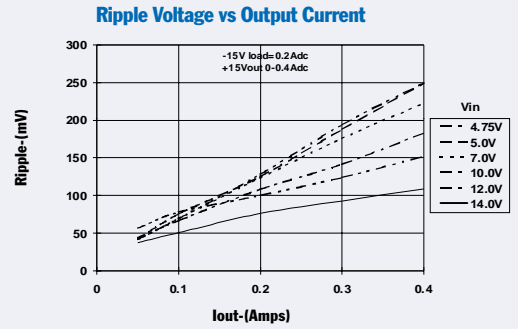
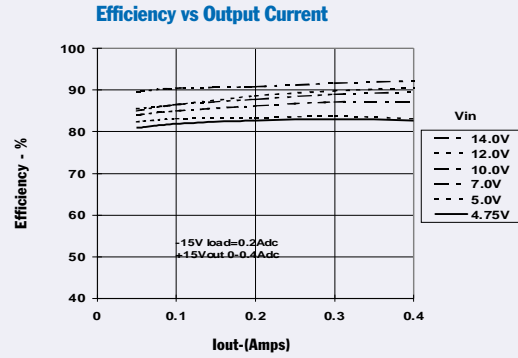

**Safe Operating Area  $V_{in} = 5.0V$ ,  $I_{o2} = 0.2A$**  (See Note B)

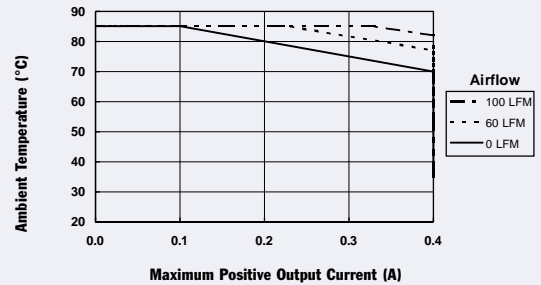

**Note A:** Characteristic data has been developed from actual products tested at 25°C. This data is considered typical data for the Converter.  
**Note B:** Thermal derating graphs are developed in free-air convection cooling, which corresponds to approximately 40-60 LFM of airflow.

## Adjusting the Output Voltage of the PT5060 Dual-Output Boost Converter Series

The dual output voltage of the PT5060 series modules can be adjusted higher or lower than the factory pre-set voltage with the addition of a single external resistor. Table 1 gives the applicable adjustment range for each model in the series as  $V_a$  (min) and  $V_a$  (max).

**Adjust Up:** An increase in the output voltage is obtained by adding a resistor  $R_2$ , between pin 11 ( $V_o$  adj) and pins 2, 6, or 7 (GND).

**Adjust Down:** Add a resistor ( $R_1$ ), between pin 11 ( $V_o$  adj) and pins 8, 9 or 10 ( $V_{o1}$ ).

Refer to Figure 1 and Table 2 for both the placement and value of the required resistor, either ( $R_1$ ) or  $R_2$  as appropriate.

### Notes:

- Both the positive and negative voltage outputs from the ISR are adjusted simultaneously.
- Use only a single 1% resistor in either the ( $R_1$ ) or  $R_2$  location. Place the resistor as close to the ISR as possible.
- Never connect capacitors from  $V_o$  adj to either GND or  $V_{o1}$ . Any capacitance added to the  $V_o$  adjust pin will affect the stability of the ISR.
- An increase in the output voltage must be accompanied by a corresponding reduction in the specified maximum current at each output. For  $V_{o1}$  and  $-V_{o2}$ , the revised maximum output current must be reduced to the equivalent of 6 watts and 3 watts respectively. i.e.

$$I_{o1}(\text{max}) = \frac{6}{V_a} \text{ A dc}$$

and

$$I_{o2}(\text{max}) = \frac{3}{V_a} \text{ A dc,}$$

where  $V_a$  is the adjusted output voltage.

- Adjustments to the output voltage will also limit the maximum input voltage that can be applied to the ISR. The maximum input voltage that may be applied is limited to  $(V_o - 1)\text{Vdc}$  or 14Vdc, whichever is less.

Figure 1

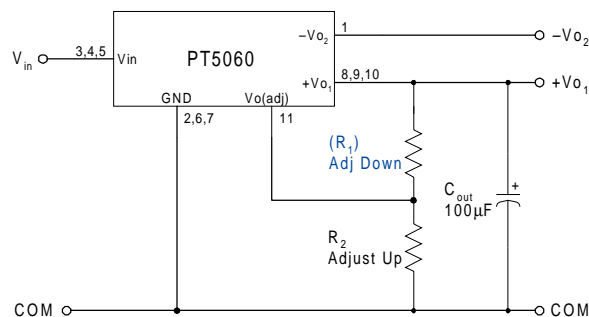

The values of ( $R_1$ ) [adjust down], and  $R_2$  [adjust up], can also be calculated using the following formulas.

$$(R_1) = \frac{3.65 (V_a - 2.5)}{(V_o - V_a)} - 0.1 \quad \text{k}\Omega$$

$$R_2 = \frac{9.125}{V_a - V_o} - 0.1 \quad \text{k}\Omega$$

Where:  $V_o$  = Original output voltage  
 $V_a$  = Adjusted output voltage

Table 1

PT5060 ADJUSTMENT AND FORMULA PARAMETERS		
Series Pt #	PT5061	PT5062
$V_o$ (nom)	$\pm 12.0\text{V}$	$\pm 15.0\text{V}$
$V_a$ (min)	$\pm 7.5\text{V}$	$\pm 7.5\text{V}$
$V_a$ (max)	$\pm 14.0\text{V}$	$\pm 20.0\text{V}$

Table 2

PT5060 ADJUSTMENT RESISTOR VALUES		
Series Pt #	PT5061	PT5062
Current	0.5/0.25A dc	0.4/0.2A dc
$V_o$ (nom)	$\pm 12.0\text{Vdc}$	$\pm 15.0\text{Vdc}$
$V_a$ (req'd)		
7.0		
7.5	(4.0)k $\Omega$	(2.3)k $\Omega$
8.0	(4.9)k $\Omega$	(2.8)k $\Omega$
8.5	(6.2)k $\Omega$	(3.3)k $\Omega$
9.0	(7.8)k $\Omega$	(3.9)k $\Omega$
9.5	(10.1)k $\Omega$	(4.6)k $\Omega$
10.0	(13.6)k $\Omega$	(5.4)k $\Omega$
10.5	(19.4)k $\Omega$	(6.4)k $\Omega$
11.0	(30.9)k $\Omega$	(7.7)k $\Omega$
11.5	(65.6)k $\Omega$	(9.3)k $\Omega$
12.0		(11.5)k $\Omega$
12.5	18.2k $\Omega$	(14.5)k $\Omega$
13.0	9.0k $\Omega$	(19.1)k $\Omega$
13.5	6.0k $\Omega$	(26.7)k $\Omega$
14.0	4.5k $\Omega$	(41.9)k $\Omega$
14.5		(87.5)k $\Omega$
15.0		
15.5		18.2k $\Omega$
16.0		9.0k $\Omega$
16.5		6.0k $\Omega$
17.0		4.5k $\Omega$
17.5		3.6k $\Omega$
18.0		2.9k $\Omega$
18.5		2.5k $\Omega$
19.0		2.2k $\Omega$
19.5		1.9k $\Omega$
20.0		1.7k $\Omega$

$R_1$  = (Blue)       $R_2$  = Black

**PACKAGING INFORMATION**

Orderable Device	Status <sup>(1)</sup>	Package Type	Package Drawing	Pins	Package Qty	Eco Plan <sup>(2)</sup>	Lead/ Ball Finish	MSL Peak Temp <sup>(3)</sup>	Samples (Requires Login)
PT5061A	NRND	SIP MODULE	ECA	12	12	Pb-Free (RoHS)	Call TI	N / A for Pkg Type	Samples Not Available
PT5061C	NRND	SIP MODULE	ECC	12	12	Pb-Free (RoHS)	Call TI	Level-1-215C-UNLIM	Samples Not Available
PT5061N	NRND	SIP MODULE	ECD	12	12	Pb-Free (RoHS)	Call TI	N / A for Pkg Type	Samples Not Available
PT5061R	NRND	SIP MODULE	ECE	12	12	Pb-Free (RoHS)	Call TI	N / A for Pkg Type	Samples Not Available
PT5062A	NRND	SIP MODULE	ECA	12	12	Pb-Free (RoHS)	Call TI	N / A for Pkg Type	Samples Not Available
PT5062C	NRND	SIP MODULE	ECC	12	12	Pb-Free (RoHS)	Call TI	Level-1-215C-UNLIM	Samples Not Available
PT5062G	NRND	SIP MODULE	ECG	12	12	Pb-Free (RoHS)	Call TI	N / A for Pkg Type	Samples Not Available
PT5062N	NRND	SIP MODULE	ECD	12	12	Pb-Free (RoHS)	Call TI	N / A for Pkg Type	Samples Not Available

<sup>(1)</sup> The marketing status values are defined as follows:

**ACTIVE:** Product device recommended for new designs.

**LIFEBUY:** TI has announced that the device will be discontinued, and a lifetime-buy period is in effect.

**NRND:** Not recommended for new designs. Device is in production to support existing customers, but TI does not recommend using this part in a new design.

**PREVIEW:** Device has been announced but is not in production. Samples may or may not be available.

**OBSELETE:** TI has discontinued the production of the device.

<sup>(2)</sup> Eco Plan - The planned eco-friendly classification: Pb-Free (RoHS), Pb-Free (RoHS Exempt), or Green (RoHS & no Sb/Br) - please check <http://www.ti.com/productcontent> for the latest availability information and additional product content details.

**TBD:** The Pb-Free/Green conversion plan has not been defined.

**Pb-Free (RoHS):** TI's terms "Lead-Free" or "Pb-Free" mean semiconductor products that are compatible with the current RoHS requirements for all 6 substances, including the requirement that lead not exceed 0.1% by weight in homogeneous materials. Where designed to be soldered at high temperatures, TI Pb-Free products are suitable for use in specified lead-free processes.

**Pb-Free (RoHS Exempt):** This component has a RoHS exemption for either 1) lead-based flip-chip solder bumps used between the die and package, or 2) lead-based die adhesive used between the die and leadframe. The component is otherwise considered Pb-Free (RoHS compatible) as defined above.

**Green (RoHS & no Sb/Br):** TI defines "Green" to mean Pb-Free (RoHS compatible), and free of Bromine (Br) and Antimony (Sb) based flame retardants (Br or Sb do not exceed 0.1% by weight in homogeneous material)

<sup>(3)</sup> MSL, Peak Temp. -- The Moisture Sensitivity Level rating according to the JEDEC industry standard classifications, and peak solder temperature.

**Important Information and Disclaimer:** The information provided on this page represents TI's knowledge and belief as of the date that it is provided. TI bases its knowledge and belief on information provided by third parties, and makes no representation or warranty as to the accuracy of such information. Efforts are underway to better integrate information from third parties. TI has taken and continues to take reasonable steps to provide representative and accurate information but may not have conducted destructive testing or chemical analysis on incoming materials and chemicals. TI and TI suppliers consider certain information to be proprietary, and thus CAS numbers and other limited information may not be available for release.

In no event shall TI's liability arising out of such information exceed the total purchase price of the TI part(s) at issue in this document sold by TI to Customer on an annual basis.

## IMPORTANT NOTICE

Texas Instruments Incorporated and its subsidiaries (TI) reserve the right to make corrections, modifications, enhancements, improvements, and other changes to its products and services at any time and to discontinue any product or service without notice. Customers should obtain the latest relevant information before placing orders and should verify that such information is current and complete. All products are sold subject to TI's terms and conditions of sale supplied at the time of order acknowledgment.

TI warrants performance of its hardware products to the specifications applicable at the time of sale in accordance with TI's standard warranty. Testing and other quality control techniques are used to the extent TI deems necessary to support this warranty. Except where mandated by government requirements, testing of all parameters of each product is not necessarily performed.

TI assumes no liability for applications assistance or customer product design. Customers are responsible for their products and applications using TI components. To minimize the risks associated with customer products and applications, customers should provide adequate design and operating safeguards.

TI does not warrant or represent that any license, either express or implied, is granted under any TI patent right, copyright, mask work right, or other TI intellectual property right relating to any combination, machine, or process in which TI products or services are used. Information published by TI regarding third-party products or services does not constitute a license from TI to use such products or services or a warranty or endorsement thereof. Use of such information may require a license from a third party under the patents or other intellectual property of the third party, or a license from TI under the patents or other intellectual property of TI.

Reproduction of TI information in TI data books or data sheets is permissible only if reproduction is without alteration and is accompanied by all associated warranties, conditions, limitations, and notices. Reproduction of this information with alteration is an unfair and deceptive business practice. TI is not responsible or liable for such altered documentation. Information of third parties may be subject to additional restrictions.

Resale of TI products or services with statements different from or beyond the parameters stated by TI for that product or service voids all express and any implied warranties for the associated TI product or service and is an unfair and deceptive business practice. TI is not responsible or liable for any such statements.

TI products are not authorized for use in safety-critical applications (such as life support) where a failure of the TI product would reasonably be expected to cause severe personal injury or death, unless officers of the parties have executed an agreement specifically governing such use. Buyers represent that they have all necessary expertise in the safety and regulatory ramifications of their applications, and acknowledge and agree that they are solely responsible for all legal, regulatory and safety-related requirements concerning their products and any use of TI products in such safety-critical applications, notwithstanding any applications-related information or support that may be provided by TI. Further, Buyers must fully indemnify TI and its representatives against any damages arising out of the use of TI products in such safety-critical applications.

TI products are neither designed nor intended for use in military/aerospace applications or environments unless the TI products are specifically designated by TI as military-grade or "enhanced plastic." Only products designated by TI as military-grade meet military specifications. Buyers acknowledge and agree that any such use of TI products which TI has not designated as military-grade is solely at the Buyer's risk, and that they are solely responsible for compliance with all legal and regulatory requirements in connection with such use.

TI products are neither designed nor intended for use in automotive applications or environments unless the specific TI products are designated by TI as compliant with ISO/TS 16949 requirements. Buyers acknowledge and agree that, if they use any non-designated products in automotive applications, TI will not be responsible for any failure to meet such requirements.

Following are URLs where you can obtain information on other Texas Instruments products and application solutions:

<b>Products</b>		<b>Applications</b>	
Amplifiers	<a href="http://amplifier.ti.com">amplifier.ti.com</a>	Audio	<a href="http://www.ti.com/audio">www.ti.com/audio</a>
Data Converters	<a href="http://dataconverter.ti.com">dataconverter.ti.com</a>	Automotive	<a href="http://www.ti.com/automotive">www.ti.com/automotive</a>
DLP® Products	<a href="http://www.dlp.com">www.dlp.com</a>	Communications and Telecom	<a href="http://www.ti.com/communications">www.ti.com/communications</a>
DSP	<a href="http://dsp.ti.com">dsp.ti.com</a>	Computers and Peripherals	<a href="http://www.ti.com/computers">www.ti.com/computers</a>
Clocks and Timers	<a href="http://www.ti.com/clocks">www.ti.com/clocks</a>	Consumer Electronics	<a href="http://www.ti.com/consumer-apps">www.ti.com/consumer-apps</a>
Interface	<a href="http://interface.ti.com">interface.ti.com</a>	Energy	<a href="http://www.ti.com/energy">www.ti.com/energy</a>
Logic	<a href="http://logic.ti.com">logic.ti.com</a>	Industrial	<a href="http://www.ti.com/industrial">www.ti.com/industrial</a>
Power Mgmt	<a href="http://power.ti.com">power.ti.com</a>	Medical	<a href="http://www.ti.com/medical">www.ti.com/medical</a>
Microcontrollers	<a href="http://microcontroller.ti.com">microcontroller.ti.com</a>	Security	<a href="http://www.ti.com/security">www.ti.com/security</a>
RFID	<a href="http://www.ti-rfid.com">www.ti-rfid.com</a>	Space, Avionics & Defense	<a href="http://www.ti.com/space-avionics-defense">www.ti.com/space-avionics-defense</a>
RF/IF and ZigBee® Solutions	<a href="http://www.ti.com/lprf">www.ti.com/lprf</a>	Video and Imaging	<a href="http://www.ti.com/video">www.ti.com/video</a>
		Wireless	<a href="http://www.ti.com/wireless-apps">www.ti.com/wireless-apps</a>