

SN65LVDS32A, SN65LVDT32A, SN65LVDS3486A SN65LVDT3486A, SN65LVDS9637A, SN65LVDT9637A HIGH-SPEED DIFFERENTIAL RECEIVERS

SLLS368E – JULY 1999 – REVISED JUNE 2001

- Meets or Exceeds the Requirements of ANSI EIA/TIA-644 Standard for Signaling Rates† up to 400 Mbps
- Operates With a Single 3.3-V Supply
- -2-V to 4.4-V Common-Mode Input Voltage Range
- Differential Input Thresholds <50 mV With 50 mV of Hysteresis Over Entire Common-Mode Input Voltage Range
- Integrated 110-Ω Line Termination Resistors Offered With the LVDT Series
- Propagation Delay Times 4 ns (typ)
- Active Fail Safe Assures a High-Level Output With No Input
- Recommended Maximum Parallel Rate of 100 M-Transfers/s
- Outputs High-Impedance With $V_{CC} < 1.5$ V
- Available in Small-Outline Package With 1,27 mm Terminal Pitch
- Pin-Compatible With the AM26LS32, MC3486, or μ A9637

description

This family of differential line receivers offers improved performance and features that implement the electrical characteristics of low-voltage differential signaling (LVDS). LVDS is defined in the TIA/EIA-644 standard. This improved performance represents the second generation of receiver products for this standard, providing a better overall solution for the cabled environment. The next generation family of products is an extension to TI's overall product portfolio and is not necessarily a replacement for older LVDS receivers.

Improved features include an input common-mode voltage range 2 V wider than the minimum required by the standard. This will allow longer cable lengths by tripling the allowable ground noise tolerance to 3 V between a driver and receiver.

NOT RECOMMENDED FOR NEW DESIGNS

For Replacement Use SN65LVDS32B or SN65LVDT32B

SN65LVDS32A, SN65LVDT32A

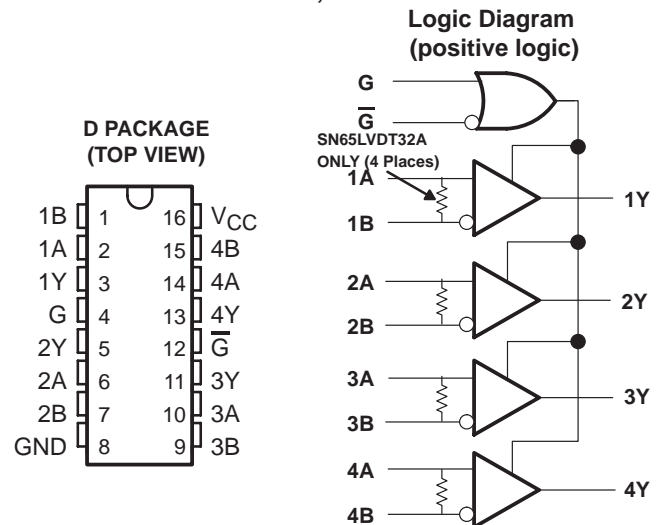

For Replacement Use SN65LVDS3486B or SN65LVDT3486B

SN65LVDS3486A, SN65LVDT3486A

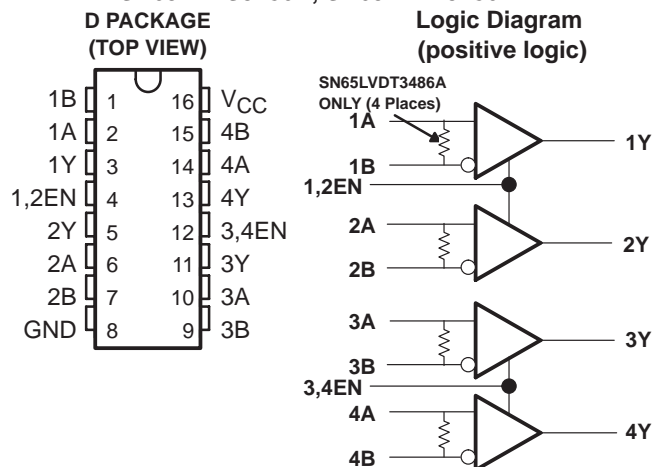

For Replacement Use SN65LVDS9637B or SN65LVDT9637B

SN65LVDS9637A, SN65LVDT9637A

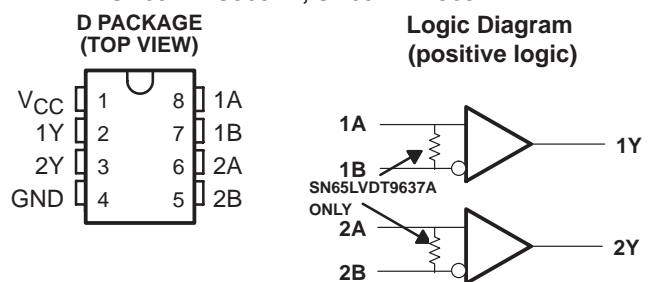

Please be aware that an important notice concerning availability, standard warranty, and use in critical applications of Texas Instruments semiconductor products and disclaimers thereto appears at the end of this data sheet.

† Signaling rate, $1/t$, where t is the minimum unit interval and is expressed in the units bits/s (bits per second)

PRODUCTION DATA information is current as of publication date. Products conform to specifications per the terms of Texas Instruments standard warranty. Production processing does not necessarily include testing of all parameters.

**TEXAS
INSTRUMENTS**

POST OFFICE BOX 655303 • DALLAS, TEXAS 75265

Copyright © 2001, Texas Instruments Incorporated

**SN65LVDS32A, SN65LVDT32A, SN65LVDS3486A
SN65LVDT3486A, SN65LVDS9637A, SN65LVDT9637A
HIGH-SPEED DIFFERENTIAL RECEIVERS**

SLLS368E – JULY 1999 – REVISED JUNE 2001

description (continued)

Precise control of the differential input voltage thresholds now allows for inclusion of 50 mV of input voltage hysteresis to improve noise rejection on slowly changing input signals. The input thresholds are still no more than ± 50 mV over the full input common-mode voltage range.

The high-speed switching of LVDS signals almost always necessitates the use of a line impedance matching resistor at the receiving-end of the cable or transmission media. The SN65LVDT series of receivers eliminates this external resistor by integrating it with the receiver. The nonterminated SN65LVDS series is also available for multidrop or other termination circuits.

The receivers also include a (patent pending) fail-safe circuit that will provide a high-level output within 600 ns after loss of the input signal. The most common causes of signal loss are disconnected cables, shorted lines, or powered-down transmitters. This prevents noise from being received as valid data under these fault conditions. This feature may also be used for wired-OR bus signaling.

The intended application of these devices and signaling technique is for point-to-point baseband data transmission over controlled impedance media of approximately 100 Ω . The transmission media may be printed-circuit board traces, backplanes, or cables. The ultimate rate and distance of data transfer is dependent upon the attenuation characteristics of the media and the noise coupling to the environment.

The SN65LVDS32A, SN65LVDT32A, SN65LVDS3486A, SN65LVDT3486A, SN65LVDS9637A, and SN65LVDT9637A are characterized for operation from -40°C to 85°C .

Function Tables
SN65LVDS32A and SN65LVDT32A

DIFFERENTIAL INPUT A-B	ENABLES		OUTPUT Y
	G	\bar{G}	
$V_{ID} \geq -70$ mV	H X	X L	H H
-100 mV $< V_{ID} \leq -70$ mV	H X	X L	? ?
$V_{ID} \leq -100$ mV	H X	X L	L L
X	L	H	Z
Open	H X	X L	H H

H = high level, L = low level, X = irrelevant,
Z = high impedance (off), ? = indeterminate

SN65LVDS3486A and SN65LVDT3486A

DIFFERENTIAL INPUT A-B	ENABLES EN	OUTPUT Y
$V_{ID} \geq -70$ mV	H	H
-100 mV $< V_{ID} \leq -70$ mV	H	?
$V_{ID} \leq -100$ mV	H	L
X	L	Z
Open	H	H

H = high level, L = low level, X = irrelevant,
Z = high impedance (off), ? = indeterminate



**SN65LVDS32A, SN65LVDT32A, SN65LVDS3486A
SN65LVDT3486A, SN65LVDS9637A, SN65LVDT9637A
HIGH-SPEED DIFFERENTIAL RECEIVERS**

SLLS368E – JULY 1999 – REVISED JUNE 2001

Function Tables (Continued)

SN65LVDS9637A and SN65LVDT9637A

DIFFERENTIAL INPUT	OUTPUT
A-B	Y
$V_{ID} \geq -70 \text{ mV}$	H
$-100 \text{ mV} < V_{ID} \leq -70 \text{ mV}$?
$V_{ID} \leq -100 \text{ mV}$	L
Open	H

H = high level, L = low level, ? = indeterminate

equivalent input and output schematic diagrams

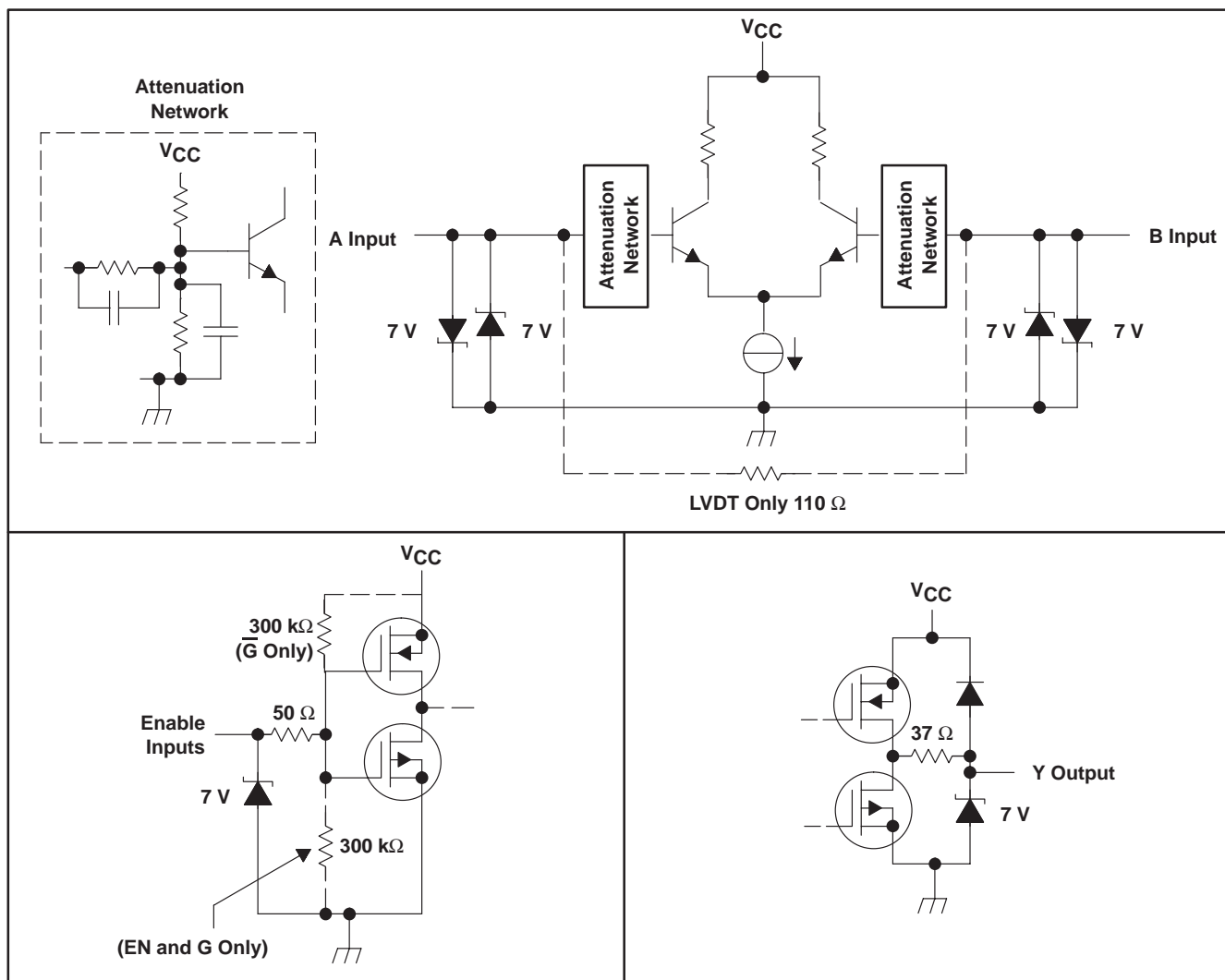

**SN65LVDS32A, SN65LVDT32A, SN65LVDS3486A
 SN65LVDT3486A, SN65LVDS9637A, SN65LVDT9637A
 HIGH-SPEED DIFFERENTIAL RECEIVERS**

SLLS368E – JULY 1999 – REVISED JUNE 2001

absolute maximum ratings over operating free-air temperature (unless otherwise noted)†

Supply voltage range, V_{CC} (see Note 1)	–0.5 V to 4 V
Voltage range: Enables or Y	–0.5 V to $V_{CC} + 3$ V
A or B	–4 V to 6 V
Bus-pin (A, B) electrostatic discharge (see Note 2)	2 kV
Continuous power dissipation	See Dissipation Rating Table
Storage temperature range	–65°C to 150°C
Lead temperature 1,6 mm (1/16 inch) from case for 10 seconds	260°C

† Stresses beyond those listed under “absolute maximum ratings” may cause permanent damage to the device. These are stress ratings only, and functional operation of the device at these or any other conditions beyond those indicated under “recommended operating conditions” is not implied. Exposure to absolute-maximum-rated conditions for extended periods may affect device reliability.

NOTES: 1. All voltage values, except differential I/O bus voltages, are with respect to network ground terminal.
 2. Tested in accordance with MIL-STD-883C Method 3015.7.

DISSIPATION RATING TABLE

PACKAGE	$T_A \leq 25^\circ\text{C}$ POWER RATING	OPERATING FACTOR‡ ABOVE $T_A = 25^\circ\text{C}$	$T_A = 85^\circ\text{C}$ POWER RATING
D8	725 mW	5.8 mW/°C	377 mW
D16	950 mW	7.6 mW/°C	494 mW

‡ This is the inverse of the junction-to-ambient thermal resistance when board-mounted and with no air flow.

recommended operating conditions

		MIN	NOM	MAX	UNIT
Supply voltage, V_{CC}		3	3.3	3.6	V
High-level input voltage, V_{IH}	Enables	2			V
Low-level input voltage, V_{IL}	Enables			0.8	V
Magnitude of differential input voltage, $ V_{ID} $		0.1		3	V
Common-mode input voltage, V_{IC}		–2		4.4	V
Operating free-air temperature, T_A		–40		85	°C



**SN65LVDS32A, SN65LVDT32A, SN65LVDS3486A
SN65LVDT3486A, SN65LVDS9637A, SN65LVDT9637A
HIGH-SPEED DIFFERENTIAL RECEIVERS**

SLLS368E – JULY 1999 – REVISED JUNE 2001

electrical characteristics over recommended operating conditions (unless otherwise noted)

PARAMETER		TEST CONDITIONS	MIN	TYP†	MAX	UNIT	
V _I TH1	Positive-going differential input voltage threshold	V _I B = -2 V or 4.4 V, See Figure 1			50	mV	
V _I TH2	Negative-going differential input voltage threshold				-50		
V _I TH3	Differential input fail-safe voltage threshold	See Figure 2 and Table 1	-70		-100	mV	
V _{ID} (HYS)	Differential input voltage hysteresis, V _I TH1 - V _I TH2			50		mV	
V _{OH}	High-level output voltage	I _{OH} = -8 mA		2.4		V	
V _{OL}	Low-level output voltage	I _{OL} = 8 mA			0.4	V	
I _{CC}	Supply current	'32A or '3486A	G or EN at V _{CC} , No load, Steady-state		16	23	mA
			G or EN at GND		1.1	5	
		'9637A	No load, Steady-state		8	12	
I _I	Input current (A or B inputs)	SN65LVDS	V _I = 0 V, Other input open			±20	μA
			V _I = 2.4 V, Other input open			±20	
			V _I = -2 V, Other input open			±40	
			V _I = 4.4 V, Other input open			±40	
		SN65LVDT	V _I = 0 V, Other input open			±40	μA
			V _I = 2.4 V, Other input open			±40	
			V _I = -2 V, Other input open			±80	
			V _I = 4.4 V, Other input open			±80	
I _{ID}	Differential input current (I _{IA} - I _{IB})	SN65LVDS	V _{ID} = 100 mV, V _{IC} = -2 V or 4.4 V, See Figure 1			±2	μA
		SN65LVDT	V _{ID} = 0.4 V, V _{IC} = -2 V or 4.4 V	3.1		4.5	mA
		SN65LVDT	V _{ID} = -0.4 V, V _{IC} = -2 V or 4.4 V	-3.1		-4.5	mA
I _I (OFF)	Power-off input current (A or B inputs)	V _A or V _B = 0 or 2.4 V, V _{CC} = 0 V				±30	μA
		V _A or V _B = -2 V or 4.4 V, V _{CC} = 0 V				±50	
I _I H	High-level input current (enables)	V _I H = 2 V				10	μA
I _I L	Low-level input current (enables)	V _I L = 0.8 V				10	μA
I _{OZ}	High-impedance output current					±10	μA
C _{IN}	Input capacitance, A or B input to GND	V _I = 0.4 sin(4E6πt) + 0.5 V				5	pF

† All typical values are at 25°C and with a 3.3 V supply.



**SN65LVDS32A, SN65LVDT32A, SN65LVDS3486A
SN65LVDT3486A, SN65LVDS9637A, SN65LVDT9637A
HIGH-SPEED DIFFERENTIAL RECEIVERS**

SLLS368E – JULY 1999 – REVISED JUNE 2001

switching characteristics over recommended operating conditions (unless otherwise noted)

PARAMETER	TEST CONDITIONS	MIN	TYP†	MAX	UNIT
t _{PLH} Propagation delay time, low-to-high-level output	C _L = 10 pF, See Figure 3	2.5	4	6	ns
t _{PHL} Propagation delay time, high-to-low-level output		2.5	4	6	ns
t _{d1} Delay time, fail-safe deactivate time				6.1	ns
t _{d2} Delay time, fail-safe activate time		0.3		1	μs
t _{sk(p)} Pulse skew (t _{PHL1} - t _{PLH1})		200			ps
t _{sk(o)} Output skew§		150			ps
t _{sk(pp)} Part-to-part skew‡				1	ns
t _r Output signal rise time				600	ps
t _f Output signal fall time			600	ps	
t _{PHZ} Propagation delay time, high-level-to-high-impedance output	See Figure 4		5.5	9	ns
t _{PLZ} Propagation delay time, low-level-to-high-impedance output			4.4	9	ns
t _{PZH} Propagation delay time, high-impedance -to-high-level output			3.8	9	ns
t _{PZL} Propagation delay time, high-impedance-to-low-level output			7	9	ns

† All typical values are at 25°C and with a 3.3 V supply.

‡ t_{sk(pp)} is the magnitude of the time difference in propagation delay times between any specified terminals of two devices when both devices operate with the same supply voltages, at the same temperature, and have identical packages and test circuits.

§ t_{sk(o)} is the magnitude of the time difference between the t_{PLH} or t_{PHL} of all receivers of a single device with all of their inputs driven together.

PARAMETER MEASUREMENT INFORMATION

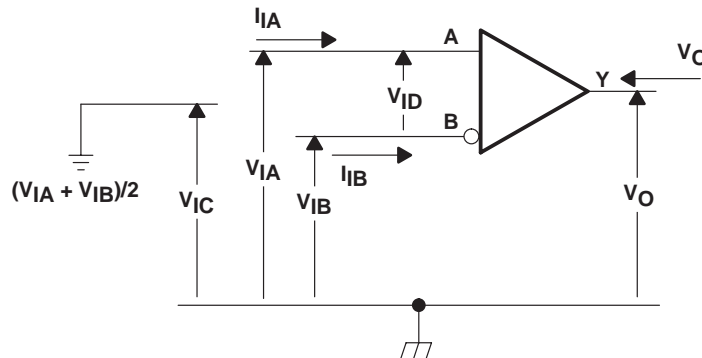

Figure 1. Voltage and Current Definitions

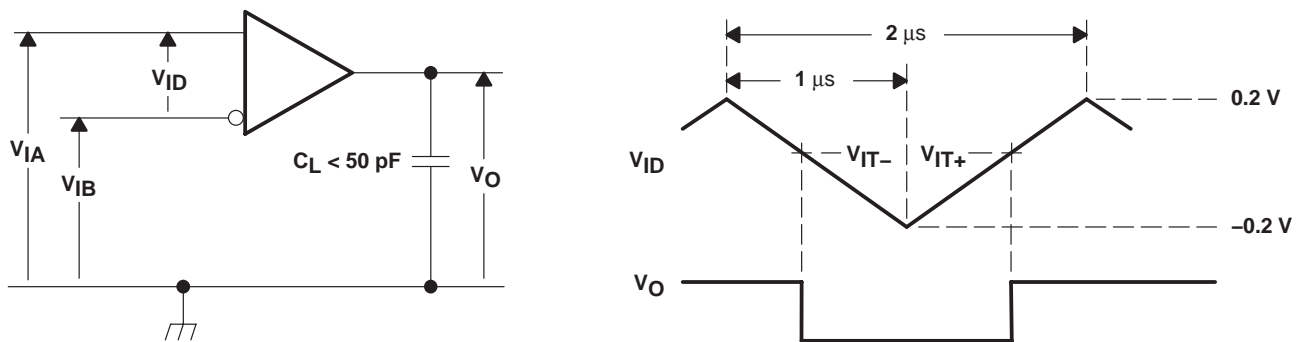

Figure 2. V_{ITH3} Input Voltage Threshold Test Circuit and Definitions

PARAMETER MEASUREMENT INFORMATION

Table 1. Receiver Minimum and Maximum Fail-Safe Input Threshold Test Voltages

APPLIED VOLTAGES†		RESULTANT INPUTS		
V _{IA} (mV)	V _{IB} (mV)	V _{ID} (mV)	V _{IC} (mV)	Output
-2050	-1950	-100	-2000	L
-2035	-1965	-70	-2000	H
4350	4450	-100	4400	L
4365	4435	-70	4400	H

† These voltages are applied for a minimum of 1 μs.

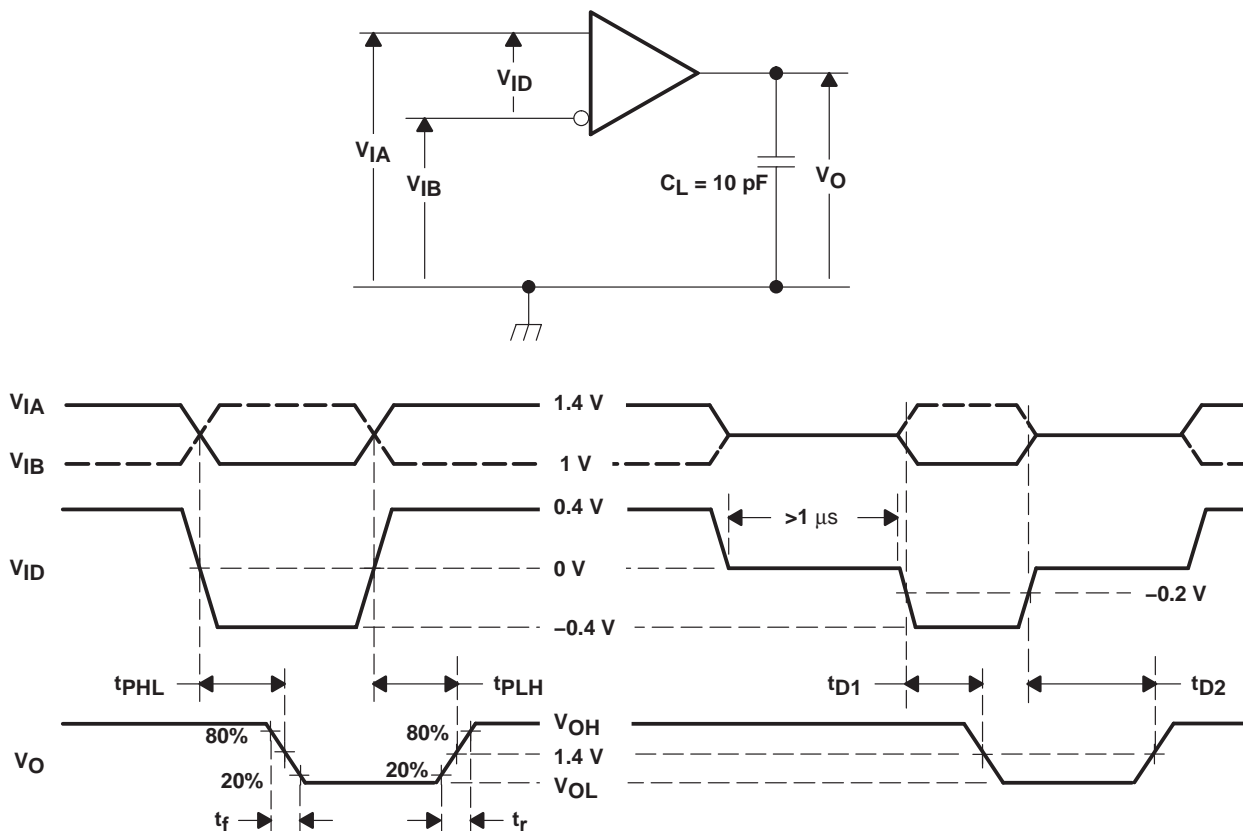

NOTE A: All input pulses are supplied by a generator having the following characteristics: t_r or $t_f \leq 1$ ns, pulse repetition rate (PRR) = 50 Mpps, pulse width = 10 ± 0.2 ns. C_L includes instrumentation and fixture capacitance within 0,06 mm of the D.U.T.

Figure 3. Timing Test Circuit and Waveforms

**SN65LVDS32A, SN65LVDT32A, SN65LVDS3486A
 SN65LVDT3486A, SN65LVDS9637A, SN65LVDT9637A
 HIGH-SPEED DIFFERENTIAL RECEIVERS**

SLLS368E – JULY 1999 – REVISED JUNE 2001

PARAMETER MEASUREMENT INFORMATION

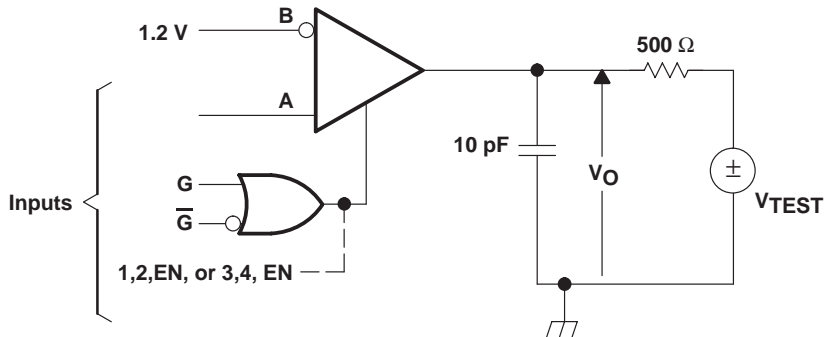

NOTE B: All input pulses are supplied by a generator having the following characteristics: t_r or $t_f \leq 1$ ns, pulse repetition rate (PRR) = 0.5 Mpps, pulse width = 500 ± 10 ns. C_L includes instrumentation and fixture capacitance within 0,06 mm of the D.U.T.

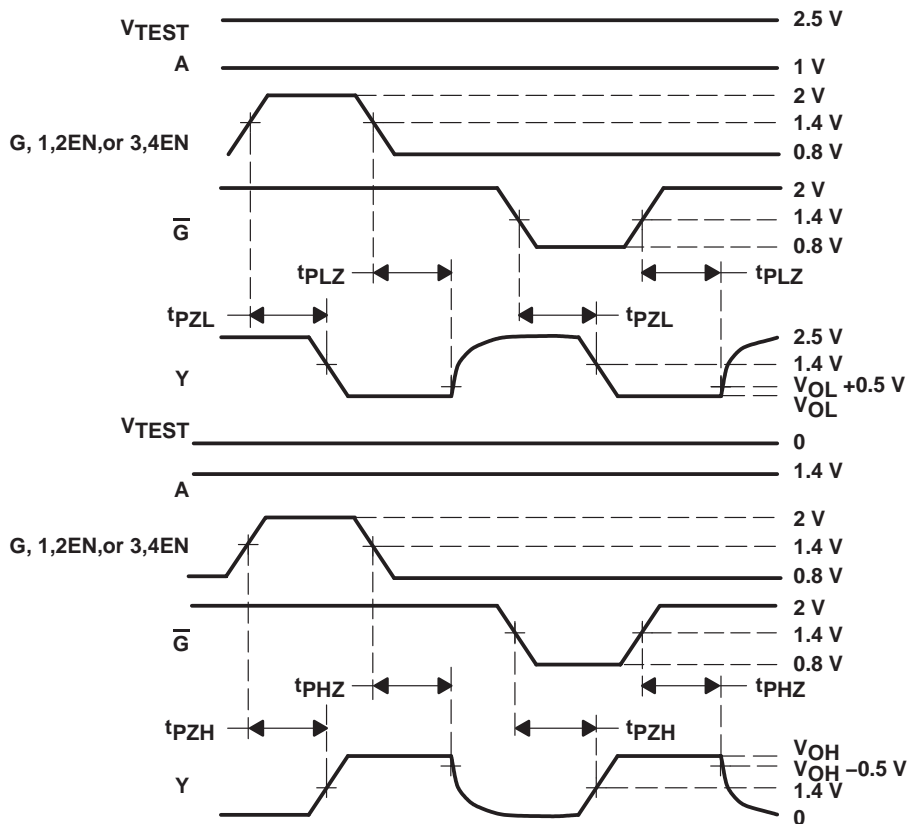

Figure 4. Enable/Disable Time Test Circuit and Waveforms

TYPICAL CHARACTERISTICS

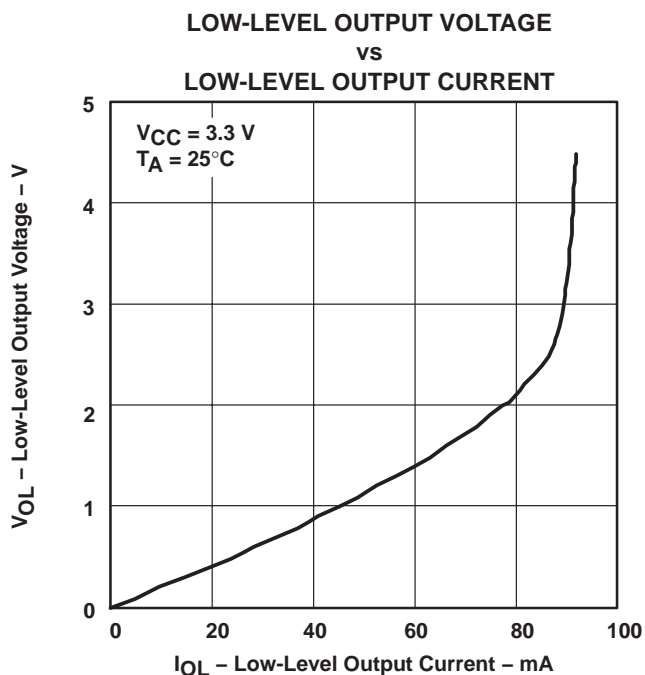

Figure 5

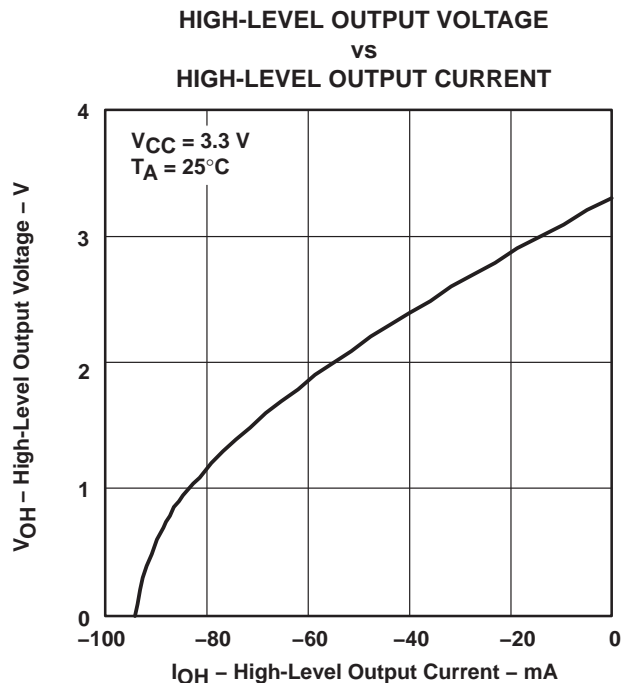

Figure 6

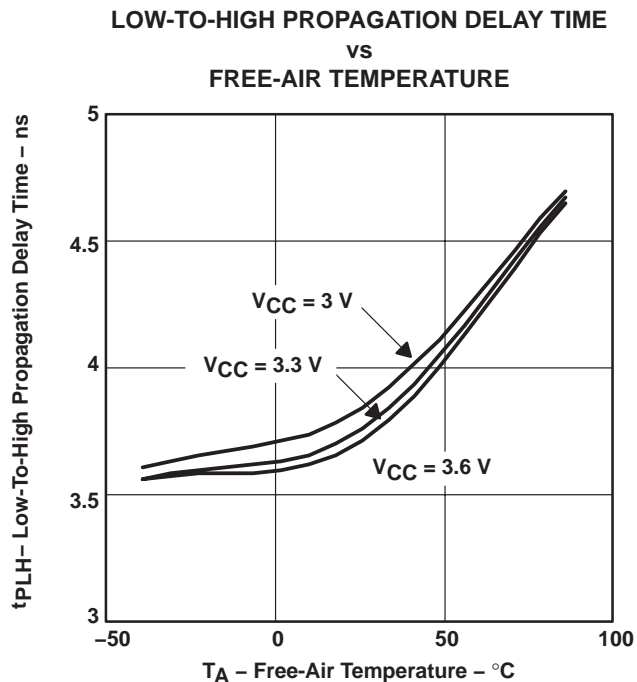

Figure 7

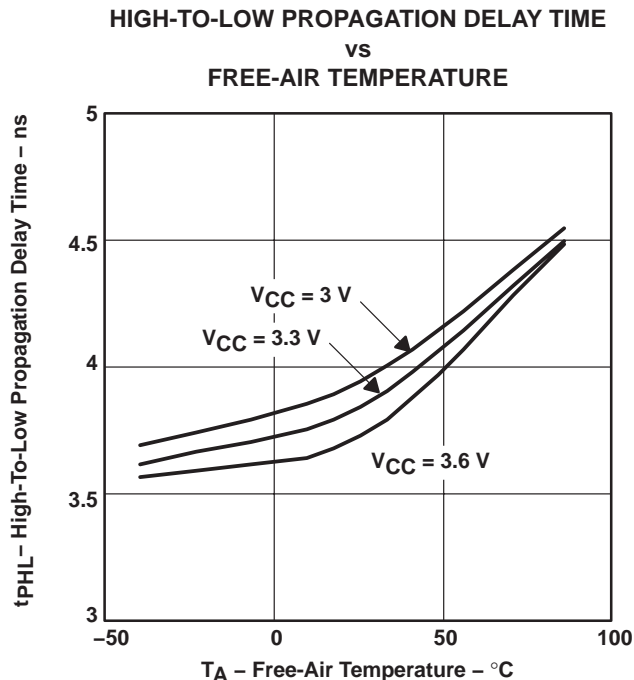

Figure 8

**SN65LVDS32A, SN65LVDT32A, SN65LVDS3486A
SN65LVDT3486A, SN65LVDS9637A, SN65LVDT9637A
HIGH-SPEED DIFFERENTIAL RECEIVERS**

SLLS368E – JULY 1999 – REVISED JUNE 2001

TYPICAL CHARACTERISTICS

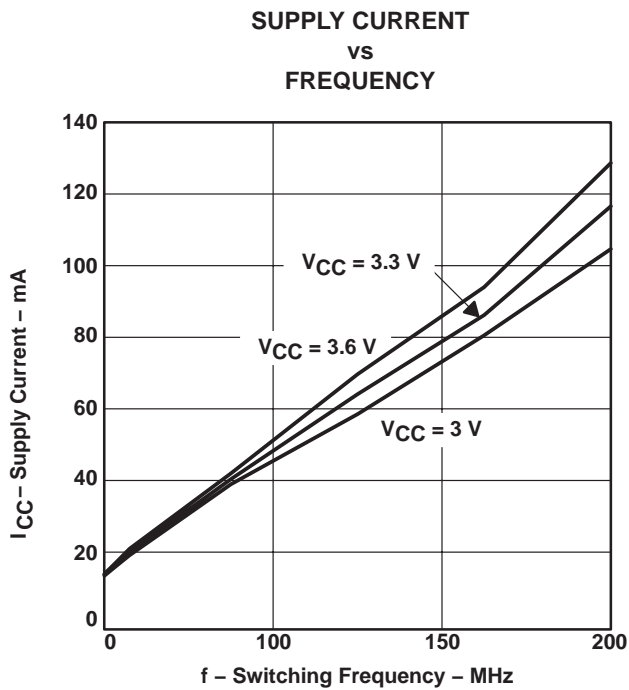
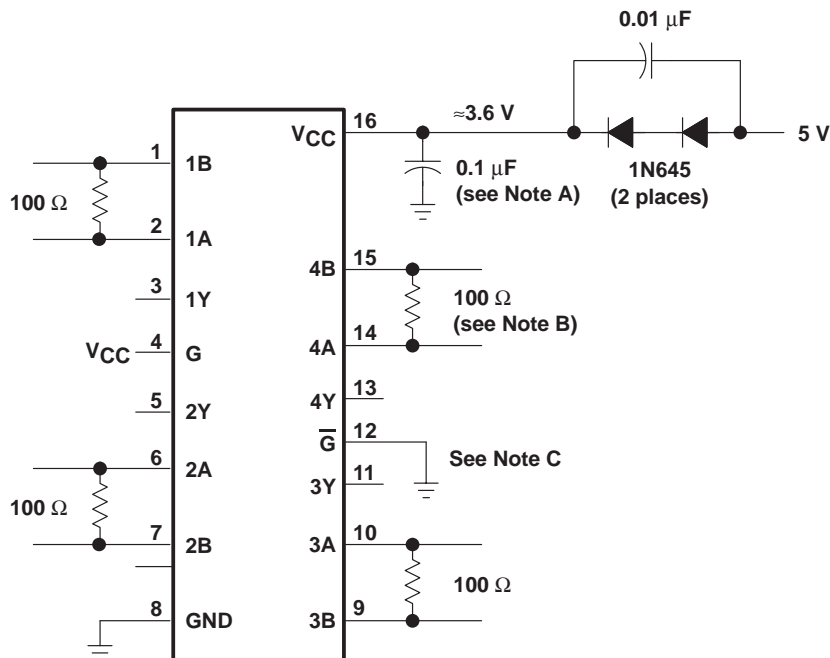

Figure 9

APPLICATION INFORMATION



- NOTES: A. Place a 0.1 μF Z5U ceramic, mica or polystyrene dielectric, 0805 size, chip capacitor between V_{CC} and the ground plane. The capacitor should be located as close as possible to the device terminals.
- B. The termination resistance value should match the nominal characteristic impedance of the transmission media with $\pm 10\%$.
- C. Unused enable inputs should be tied to V_{CC} or GND as appropriate.

Figure 10. Operation with 5-V Supply

related information

IBIS modeling is available for this device. Please contact the local TI sales office or the TI Web site at www.ti.com for more information.

For more application guidelines, please see the following documents:

- *Low-Voltage Signalling Design Notes* (TI literature number SLLA014)
- *Interface Circuits for TIA/EIA-644 (LVDS)* (SLLA038)
- *Reducing EMI With LVDS* (SLLA030)
- *Slew Rate Control of LVDS Circuits* (SLLA034)
- *Using an LVDS Receiver With RS-422 Data* (SLLA031)
- *Evaluating the LVDS EVM* (SLLA033)

SN65LVDS32A, SN65LVDT32A, SN65LVDS3486A SN65LVDT3486A, SN65LVDS9637A, SN65LVDT9637A HIGH-SPEED DIFFERENTIAL RECEIVERS

SLLS368E – JULY 1999 – REVISED JUNE 2001

APPLICATION INFORMATION

abstract terminated failsafe

A differential line receiver commonly has a fail-safe circuit to prevent it from switching on input noise. Current LVDS fail-safe solutions require either external components with subsequent reduction in signal quality or integrated solutions with limited application. This family of receivers has a new integrated fail-safe that solves the limitations in present solutions. A detailed theory of operation is presented in the application note *The Active Fail-Safe Feature of the SN65LVDS32A*, literature number SLLA082.

Figure 11 shows one receiver channel with active fail-safe. It consists of a main receiver that can respond to a high-speed input differential signal. Also connected to the input pair are two fail-safe receivers that form a window comparator. The window comparator has a much slower response than the main receiver and detects when the input differential falls below 80 mV. A 600-ns fail-safe timer filters the window comparator outputs. When fail-safe is asserted, the fail-safe logic drives the main receiver output to logic high.

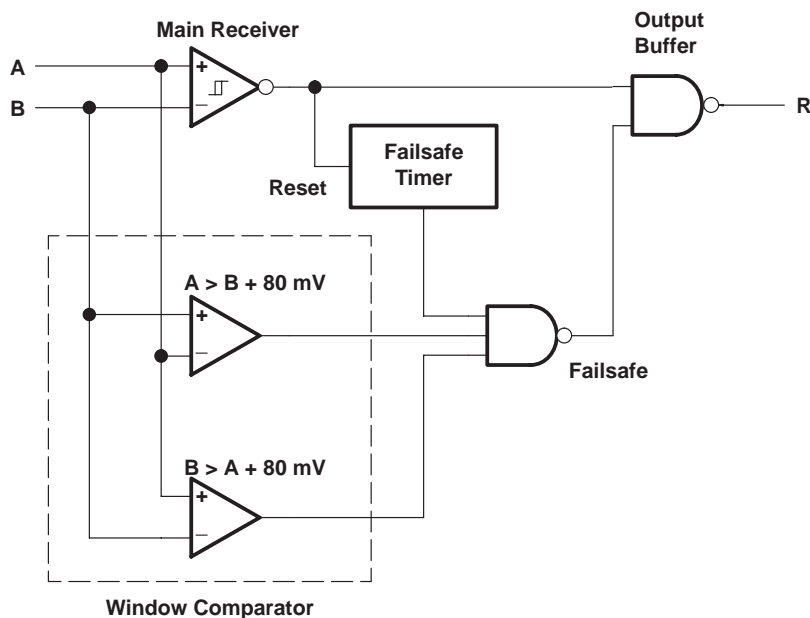

Figure 11. Receiver With Terminated Failsafe

APPLICATION INFORMATION

test conditions

- $V_{CC} = 3.3\text{ V}$
- $T_A = 25^\circ\text{C}$ (ambient temperature)
- All four channels switching simultaneously with NRZ data. Scope is pulse-triggered simultaneously with NRZ data.

equipment

- Tektronix PS25216 programmable power supply
- Tektronix HFS 9003 stimulus system
- Tektronix TDS 784D 4-channel digital phosphor oscilloscope – DPO

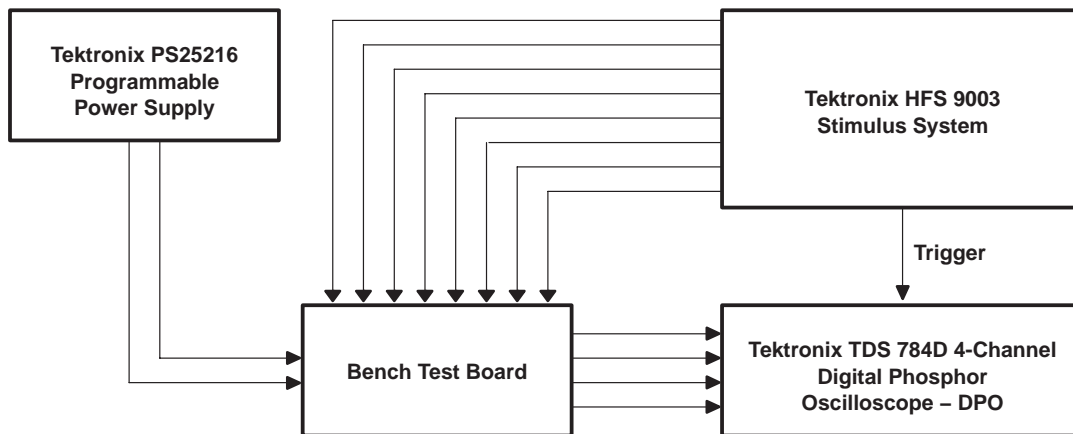

Figure 12. Equipment Setup

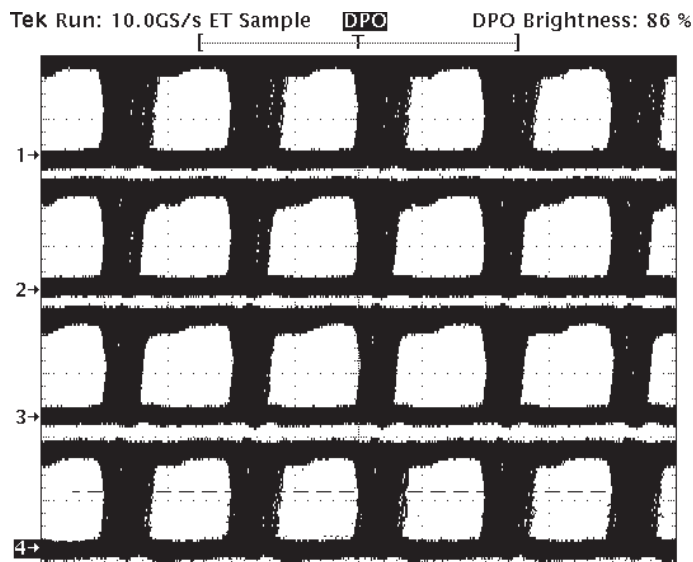

Figure 13. Typical Eye Pattern SN65LVDS32A 100 Mbit/s

**SN65LVDS32A, SN65LVDT32A, SN65LVDS3486A
 SN65LVDT3486A, SN65LVDS9637A, SN65LVDT9637A
 HIGH-SPEED DIFFERENTIAL RECEIVERS**

SLLS368E - JULY 1999 - REVISED JUNE 2001

MECHANICAL DATA

D (R-PDSO-G)**

PLASTIC SMALL-OUTLINE PACKAGE

14 PIN SHOWN

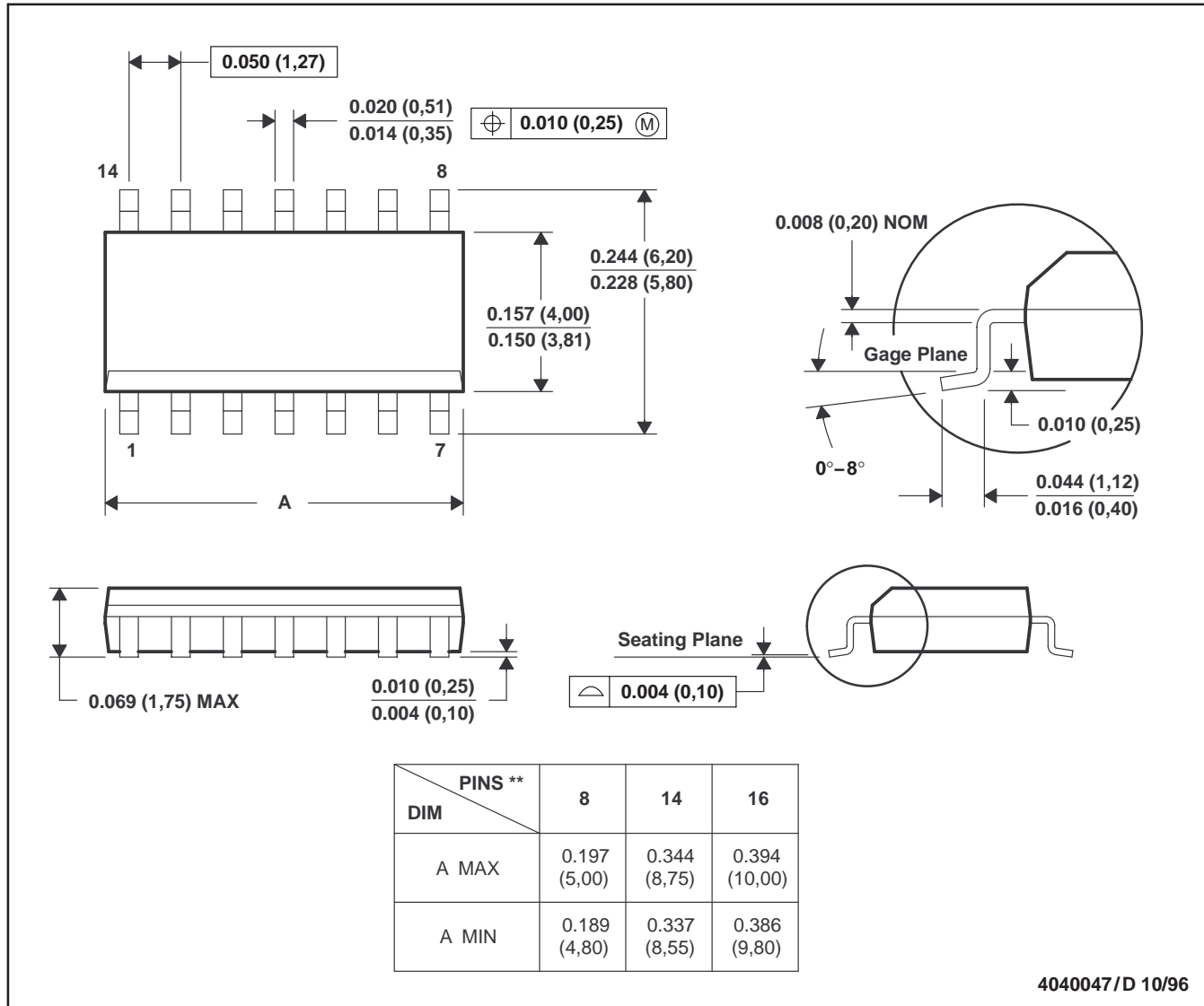

- NOTES: A. All linear dimensions are in inches (millimeters).
 B. This drawing is subject to change without notice.
 C. Body dimensions do not include mold flash or protrusion, not to exceed 0.006 (0,15).

IMPORTANT NOTICE

Texas Instruments Incorporated and its subsidiaries (TI) reserve the right to make corrections, modifications, enhancements, improvements, and other changes to its products and services at any time and to discontinue any product or service without notice. Customers should obtain the latest relevant information before placing orders and should verify that such information is current and complete. All products are sold subject to TI's terms and conditions of sale supplied at the time of order acknowledgment.

TI warrants performance of its hardware products to the specifications applicable at the time of sale in accordance with TI's standard warranty. Testing and other quality control techniques are used to the extent TI deems necessary to support this warranty. Except where mandated by government requirements, testing of all parameters of each product is not necessarily performed.

TI assumes no liability for applications assistance or customer product design. Customers are responsible for their products and applications using TI components. To minimize the risks associated with customer products and applications, customers should provide adequate design and operating safeguards.

TI does not warrant or represent that any license, either express or implied, is granted under any TI patent right, copyright, mask work right, or other TI intellectual property right relating to any combination, machine, or process in which TI products or services are used. Information published by TI regarding third-party products or services does not constitute a license from TI to use such products or services or a warranty or endorsement thereof. Use of such information may require a license from a third party under the patents or other intellectual property of the third party, or a license from TI under the patents or other intellectual property of TI.

Reproduction of TI information in TI data books or data sheets is permissible only if reproduction is without alteration and is accompanied by all associated warranties, conditions, limitations, and notices. Reproduction of this information with alteration is an unfair and deceptive business practice. TI is not responsible or liable for such altered documentation. Information of third parties may be subject to additional restrictions.

Resale of TI products or services with statements different from or beyond the parameters stated by TI for that product or service voids all express and any implied warranties for the associated TI product or service and is an unfair and deceptive business practice. TI is not responsible or liable for any such statements.

TI products are not authorized for use in safety-critical applications (such as life support) where a failure of the TI product would reasonably be expected to cause severe personal injury or death, unless officers of the parties have executed an agreement specifically governing such use. Buyers represent that they have all necessary expertise in the safety and regulatory ramifications of their applications, and acknowledge and agree that they are solely responsible for all legal, regulatory and safety-related requirements concerning their products and any use of TI products in such safety-critical applications, notwithstanding any applications-related information or support that may be provided by TI. Further, Buyers must fully indemnify TI and its representatives against any damages arising out of the use of TI products in such safety-critical applications.

TI products are neither designed nor intended for use in military/aerospace applications or environments unless the TI products are specifically designated by TI as military-grade or "enhanced plastic." Only products designated by TI as military-grade meet military specifications. Buyers acknowledge and agree that any such use of TI products which TI has not designated as military-grade is solely at the Buyer's risk, and that they are solely responsible for compliance with all legal and regulatory requirements in connection with such use.

TI products are neither designed nor intended for use in automotive applications or environments unless the specific TI products are designated by TI as compliant with ISO/TS 16949 requirements. Buyers acknowledge and agree that, if they use any non-designated products in automotive applications, TI will not be responsible for any failure to meet such requirements.

Following are URLs where you can obtain information on other Texas Instruments products and application solutions:

Products

Amplifiers	amplifier.ti.com
Data Converters	dataconverter.ti.com
DSP	dsp.ti.com
Clocks and Timers	www.ti.com/clocks
Interface	interface.ti.com
Logic	logic.ti.com
Power Mgmt	power.ti.com
Microcontrollers	microcontroller.ti.com
RFID	www.ti-rfid.com
RF/IF and ZigBee® Solutions	www.ti.com/lprf

Applications

Audio	www.ti.com/audio
Automotive	www.ti.com/automotive
Broadband	www.ti.com/broadband
Digital Control	www.ti.com/digitalcontrol
Medical	www.ti.com/medical
Military	www.ti.com/military
Optical Networking	www.ti.com/opticalnetwork
Security	www.ti.com/security
Telephony	www.ti.com/telephony
Video & Imaging	www.ti.com/video
Wireless	www.ti.com/wireless

Mailing Address: Texas Instruments, Post Office Box 655303, Dallas, Texas 75265
Copyright © 2008, Texas Instruments Incorporated