

TPS1120, TPS1120Y DUAL P-CHANNEL ENHANCEMENT-MODE MOSFETS

SLVS080A – MARCH 1994 – REVISED AUGUST 1995

- Low $r_{DS(on)}$. . . 0.18 Ω at $V_{GS} = -10$ V
- 3-V Compatible
- Requires No External V_{CC}
- TTL and CMOS Compatible Inputs
- $V_{GS(th)} = -1.5$ V Max
- ESD Protection Up to 2 kV per MIL-STD-883C, Method 3015

D PACKAGE
(TOP VIEW)

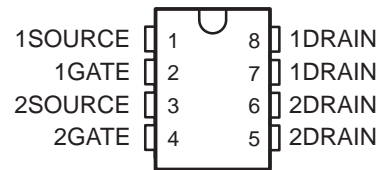

description

The TPS1120 incorporates two independent p-channel enhancement-mode MOSFETs that have been optimized, by means of the Texas Instruments LinBiCMOS™ process, for 3-V or 5-V power distribution in battery-powered systems. With a maximum $V_{GS(th)}$ of -1.5 V and an I_{DSS} of only $0.5 \mu A$, the TPS1120 is the ideal high-side switch for low-voltage portable battery-management systems, where maximizing battery life is a primary concern. Because portable equipment is potentially subject to electrostatic discharge (ESD), the MOSFETs have built-in circuitry for 2-kV ESD protection. End equipment for the TPS1120 includes notebook computers, personal digital assistants (PDAs), cellular telephones, bar-code scanners, and PCMCIA cards. For existing designs, the TPS1120D has a pinout common with other p-channel MOSFETs in small-outline integrated circuit SOIC packages.

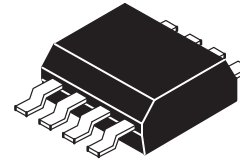

The TPS1120 is characterized for an operating junction temperature range, T_J , from $-40^\circ C$ to $150^\circ C$.

AVAILABLE OPTIONS

| T_J | PACKAGED DEVICES† | CHIP FORM (Y) |
|--------------------------------|-------------------|---------------|
| | SMALL OUTLINE (D) | |
| $-40^\circ C$ to $150^\circ C$ | TPS1120D | TPS1120Y |

† The D package is available taped and reeled. Add an R suffix to device type (e.g., TPS1120DR). The chip form is tested at $25^\circ C$.



Caution. This device contains circuits to protect its inputs and outputs against damage due to high static voltages or electrostatic fields. These circuits have been qualified to protect this device against electrostatic discharges (ESD) of up to 2 kV according to MIL-STD-883C, Method 3015; however, it is advised that precautions be taken to avoid application of any voltage higher than maximum-rated voltages to these high-impedance circuits.

LinBiCMOS is a trademark of Texas Instruments Incorporated.

PRODUCTION DATA information is current as of publication date. Products conform to specifications per the terms of Texas Instruments standard warranty. Production processing does not necessarily include testing of all parameters.

 **TEXAS
INSTRUMENTS**

POST OFFICE BOX 655303 • DALLAS, TEXAS 75265

Copyright © 1995, Texas Instruments Incorporated

TPS1120, TPS1120Y DUAL P-CHANNEL ENHANCEMENT-MODE MOSFETS

SLVS080A – MARCH 1994 – REVISED AUGUST 1995

schematic

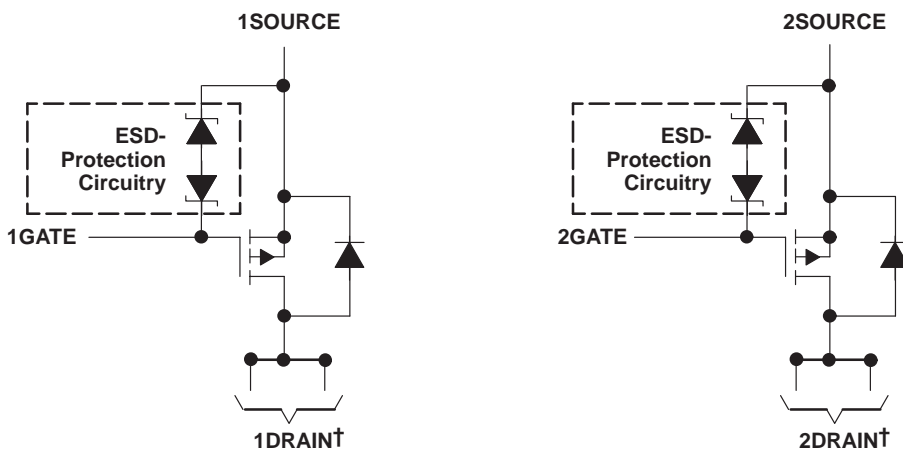

† For all applications, both drain pins for each device should be connected.

TPS1120Y chip information

This chip, when properly assembled, displays characteristics similar to the TPS1120C. Thermal compression or ultrasonic bonding may be used on the doped aluminum bonding pads. The chip may be mounted with conductive epoxy or a gold-silicon preform.

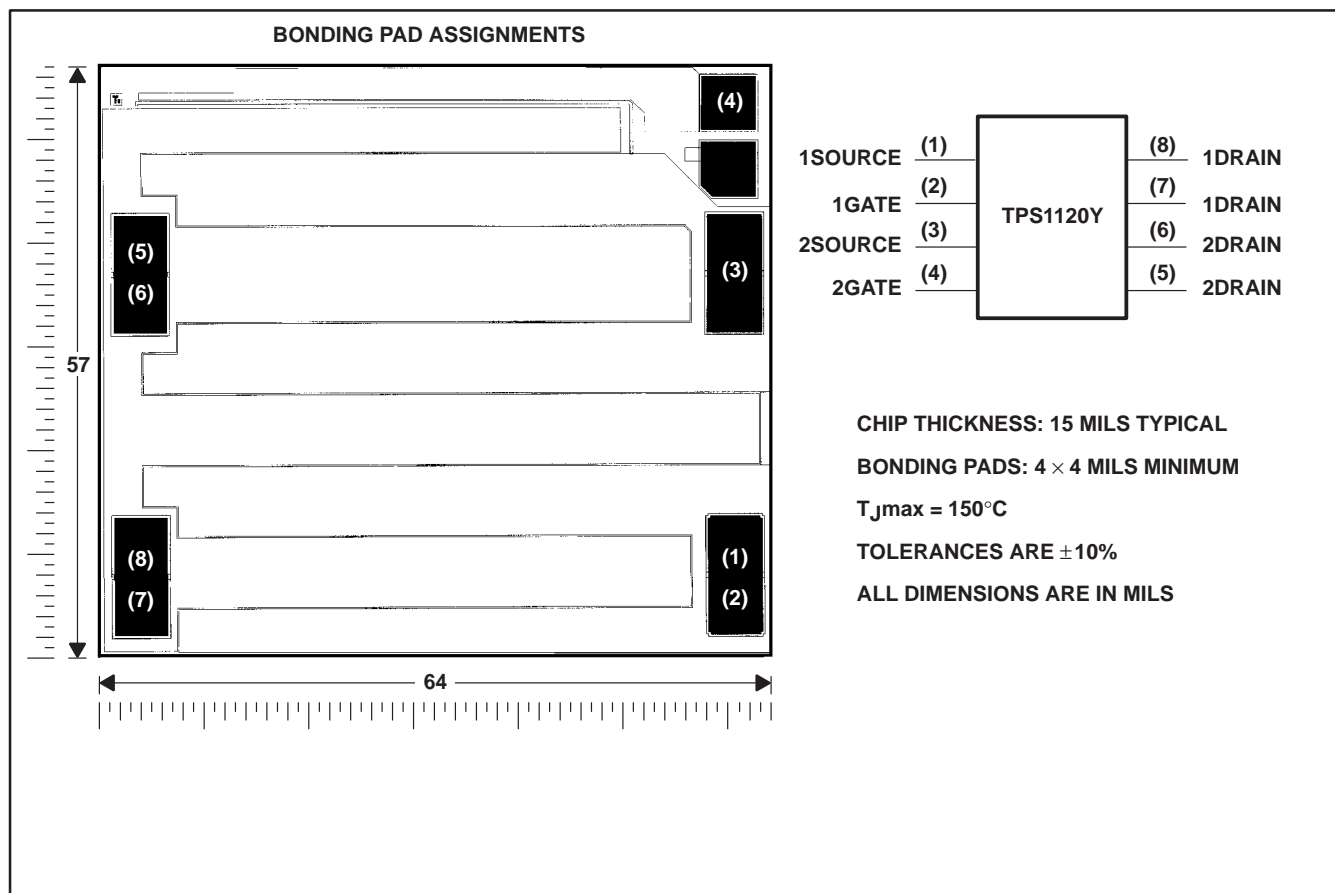

TPS1120, TPS1120Y

DUAL P-CHANNEL ENHANCEMENT-MODE MOSFETS

SLVS080A – MARCH 1994 – REVISED AUGUST 1995

absolute maximum ratings over operating free-air temperature (unless otherwise noted)[†]

| | | | UNIT |
|--|--------------------------|------------------------------|------------------|
| Drain-to-source voltage, V_{DS} | | -15 | V |
| Gate-to-source voltage, V_{GS} | | 2 or -15 | V |
| Continuous drain current, each device ($T_J = 150^\circ\text{C}$), I_D | $V_{GS} = -2.7\text{ V}$ | $T_A = 25^\circ\text{C}$ | ± 0.39 |
| | | $T_A = 125^\circ\text{C}$ | ± 0.21 |
| | $V_{GS} = -3\text{ V}$ | $T_A = 25^\circ\text{C}$ | ± 0.5 |
| | | $T_A = 125^\circ\text{C}$ | ± 0.25 |
| | $V_{GS} = -4.5\text{ V}$ | $T_A = 25^\circ\text{C}$ | ± 0.74 |
| | | $T_A = 125^\circ\text{C}$ | ± 0.34 |
| | $V_{GS} = -10\text{ V}$ | $T_A = 25^\circ\text{C}$ | ± 1.17 |
| | | $T_A = 125^\circ\text{C}$ | ± 0.53 |
| Pulse drain current, I_D | | $T_A = 25^\circ\text{C}$ | ± 7 |
| Continuous source current (diode conduction), I_S | | $T_A = 25^\circ\text{C}$ | -1 |
| Continuous total power dissipation | | See Dissipation Rating Table | |
| Storage temperature range, T_{stg} | | -55 to 150 | $^\circ\text{C}$ |
| Operating junction temperature range, T_J | | -40 to 150 | $^\circ\text{C}$ |
| Operating free-air temperature range, T_A | | -40 to 125 | $^\circ\text{C}$ |
| Lead temperature 1,6 mm (1/16 inch) from case for 10 seconds | | 260 | $^\circ\text{C}$ |

[†] Stresses beyond those listed under "absolute maximum ratings" may cause permanent damage to the device. These are stress ratings only, and functional operation of the device at these or any other conditions beyond those indicated under "recommended operating conditions" is not implied. Exposure to absolute-maximum-rated conditions for extended periods may affect device reliability.

DISSIPATION RATING TABLE

| PACKAGE | $T_A \leq 25^\circ\text{C}$ POWER RATING | DERATING FACTOR [‡] ABOVE $T_A = 25^\circ\text{C}$ | $T_A = 70^\circ\text{C}$ POWER RATING | $T_A = 85^\circ\text{C}$ POWER RATING | $T_A = 125^\circ\text{C}$ POWER RATING |
|---------|---|--|--|--|---|
| D | 840 mW | 6.71 mW/ $^\circ\text{C}$ | 538 mW | 437 mW | 169 mW |

[‡] Maximum values are calculated using a derating factor based on $R_{\theta JA} = 149^\circ\text{C}/\text{W}$ for the package. These devices are mounted on an FR4 board with no special thermal considerations.

TPS1120, TPS1120Y

DUAL P-CHANNEL ENHANCEMENT-MODE MOSFETS

SLVS080A – MARCH 1994 – REVISED AUGUST 1995

electrical characteristics at $T_J = 25^\circ\text{C}$ (unless otherwise noted)

static

| PARAMETER | TEST CONDITIONS | TPS1120 | | | UNIT |
|---|--|---------------------------|---------|-------|---------------|
| | | MIN | TYP | MAX | |
| $V_{GS(th)}$ Gate-to-source threshold voltage | $V_{DS} = V_{GS}$, $I_D = -250 \mu\text{A}$ | -1 | -1.25 | -1.50 | V |
| V_{SD} Source-to-drain voltage (diode forward voltage) [†] | $I_S = -1 \text{ A}$, $V_{GS} = 0 \text{ V}$ | -0.9 | | | V |
| I_{GSS} Reverse gate current, drain short circuited to source | $V_{DS} = 0 \text{ V}$, $V_{GS} = -12 \text{ V}$ | ±100 | | | nA |
| I_{DSS} Zero-gate-voltage drain current | $V_{DS} = -12 \text{ V}$, $V_{GS} = 0 \text{ V}$ | $T_J = 25^\circ\text{C}$ | -0.5 | | μA |
| | | $T_J = 125^\circ\text{C}$ | -10 | | |
| $r_{DS(on)}$ Static drain-to-source on-state resistance [†] | $V_{GS} = -10 \text{ V}$ | $I_D = -1.5 \text{ A}$ | 180 | | m Ω |
| | $V_{GS} = -4.5 \text{ V}$ | $I_D = -0.5 \text{ A}$ | 291 400 | | |
| | $V_{GS} = -3 \text{ V}$ | $I_D = -0.2 \text{ A}$ | 476 700 | | |
| | $V_{GS} = -2.7 \text{ V}$ | | 606 850 | | |
| g_{fs} Forward transconductance [†] | $V_{DS} = -10 \text{ V}$, $I_D = -2 \text{ A}$ | 2.5 | | | S |

[†] Pulse test: pulse width $\leq 300 \mu\text{s}$, duty cycle $\leq 2\%$

static

| PARAMETER | TEST CONDITIONS | TPS1120Y | | | UNIT |
|---|---|------------------------|-----|-----|------------|
| | | MIN | TYP | MAX | |
| $V_{GS(th)}$ Gate-to-source threshold voltage | $V_{DS} = V_{GS}$, $I_D = -250 \mu\text{A}$ | -1.25 | | | V |
| V_{SD} Source-to-drain voltage (diode forward voltage) [†] | $I_S = -1 \text{ A}$, $V_{GS} = 0 \text{ V}$ | -0.9 | | | V |
| $r_{DS(on)}$ Static drain-to-source on-state resistance [†] | $V_{GS} = -10 \text{ V}$ | $I_D = -1.5 \text{ A}$ | 180 | | m Ω |
| | $V_{GS} = -4.5 \text{ V}$ | $I_D = -0.5 \text{ A}$ | 291 | | |
| | $V_{GS} = -3 \text{ V}$ | $I_D = -0.2 \text{ A}$ | 476 | | |
| | $V_{GS} = -2.7 \text{ V}$ | | 606 | | |
| g_{fs} Forward transconductance [†] | $V_{DS} = -10 \text{ V}$, $I_D = -2 \text{ A}$ | 2.5 | | | S |

[†] Pulse test: pulse width $\leq 300 \mu\text{s}$, duty cycle $\leq 2\%$

dynamic

| PARAMETER | TEST CONDITIONS | TPS1120, TPS1120Y | | | UNIT |
|--|--|---|-----|-----|------|
| | | MIN | TYP | MAX | |
| Q_g Total gate charge | $V_{DS} = -10 \text{ V}$, $V_{GS} = -10 \text{ V}$, $I_D = -1 \text{ A}$ | 5.45 | | | nC |
| Q_{gs} Gate-to-source charge | | 0.87 | | | |
| Q_{gd} Gate-to-drain charge | | 1.4 | | | |
| $t_{d(on)}$ Turn-on delay time | $V_{DD} = -10 \text{ V}$, $R_L = 10 \Omega$, $R_G = 6 \Omega$, See Figures 1 and 2 $I_D = -1 \text{ A}$, | 4.5 | | | ns |
| $t_{d(off)}$ Turn-off delay time | | 13 | | | ns |
| t_r Rise time | | 10 | | | ns |
| t_f Fall time | | 2 | | | |
| $t_{rr(SD)}$ Source-to-drain reverse recovery time | | $I_F = 5.3 \text{ A}$, $di/dt = 100 \text{ A}/\mu\text{s}$ | 16 | | |

PARAMETER MEASUREMENT INFORMATION

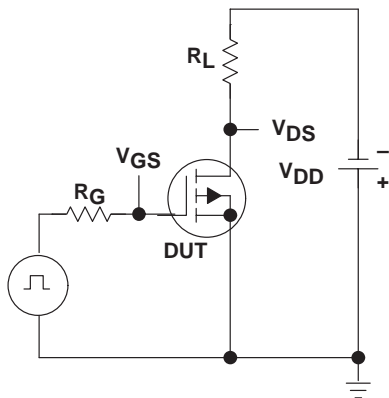

Figure 1. Switching-Time Test Circuit

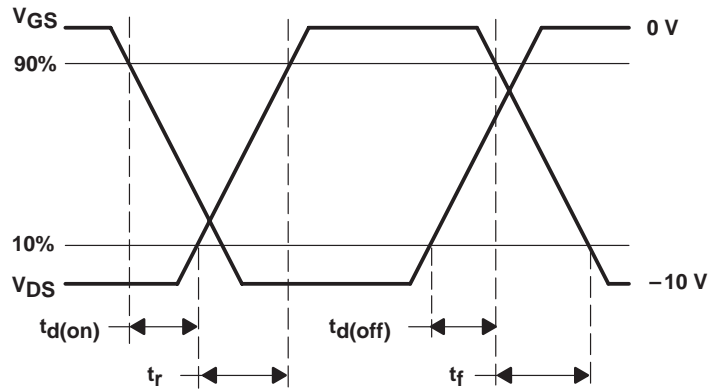

Figure 2. Switching-Time Waveforms

TPS1120, TPS1120Y DUAL P-CHANNEL ENHANCEMENT-MODE MOSFETS

SLVS080A – MARCH 1994 – REVISED AUGUST 1995

TYPICAL CHARACTERISTICS†

Table of Graphs

| | | FIGURE |
|---|----------------------------|--------|
| Drain current | vs Drain-to-source voltage | 3 |
| Drain current | vs Gate-to-source voltage | 4 |
| Static drain-to-source on-state resistance | vs Drain current | 5 |
| Capacitance | vs Drain-to-source voltage | 6 |
| Static drain-to-source on-state resistance (normalized) | vs Junction temperature | 7 |
| Source-to-drain diode current | vs Source-to-drain voltage | 8 |
| Static drain-to-source on-state resistance | vs Gate-to-source voltage | 9 |
| Gate-to-source threshold voltage | vs Junction temperature | 10 |
| Gate-to-source voltage | vs Gate charge | 11 |

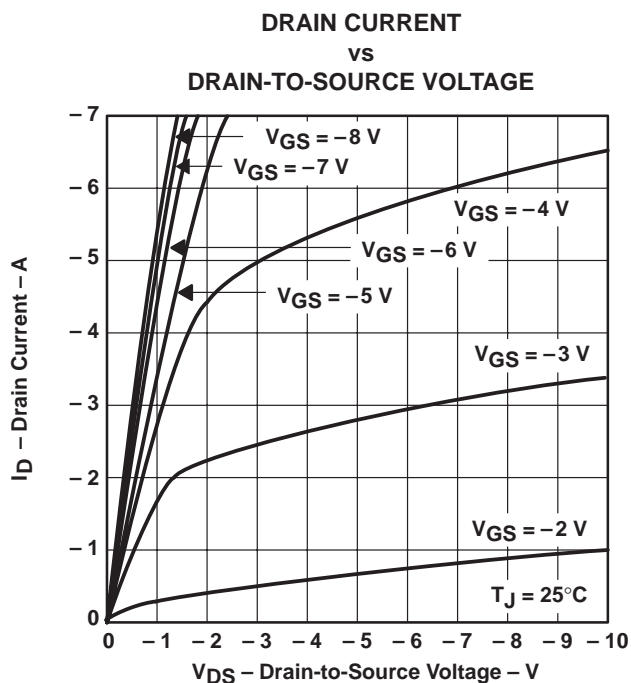

Figure 3

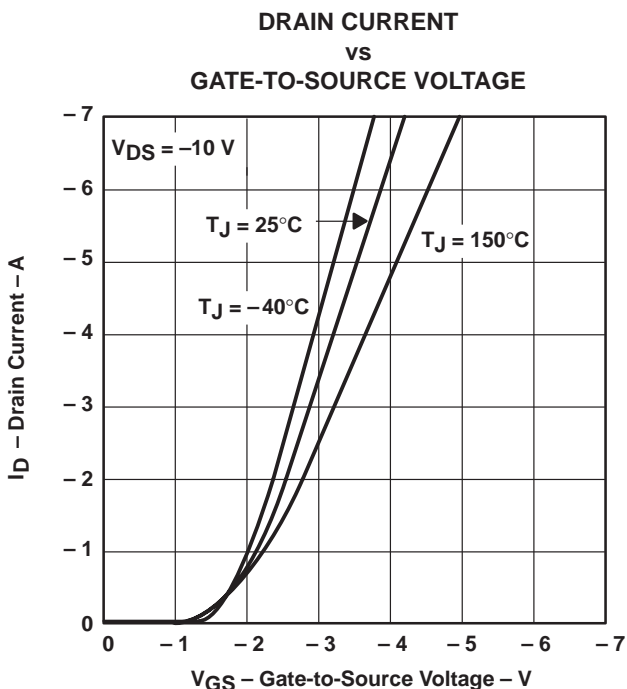

Figure 4

† All characteristics data applies for each independent MOSFET incorporated on the TPS1120.

TYPICAL CHARACTERISTICS

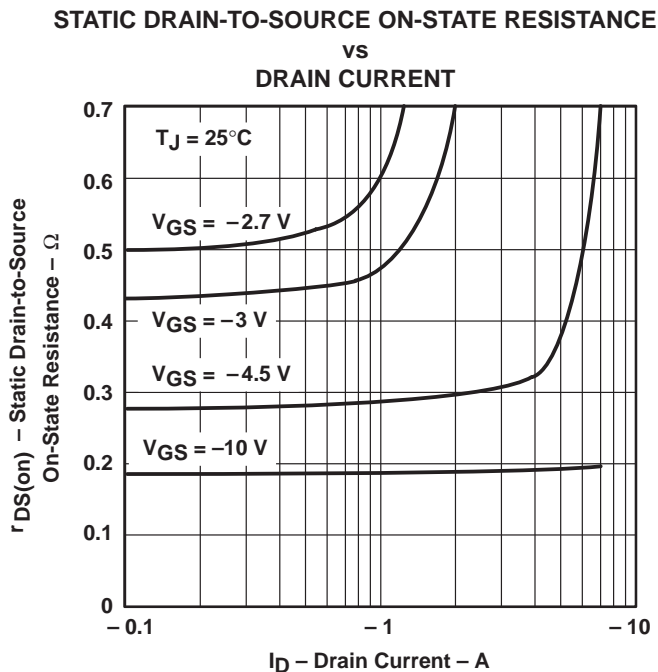
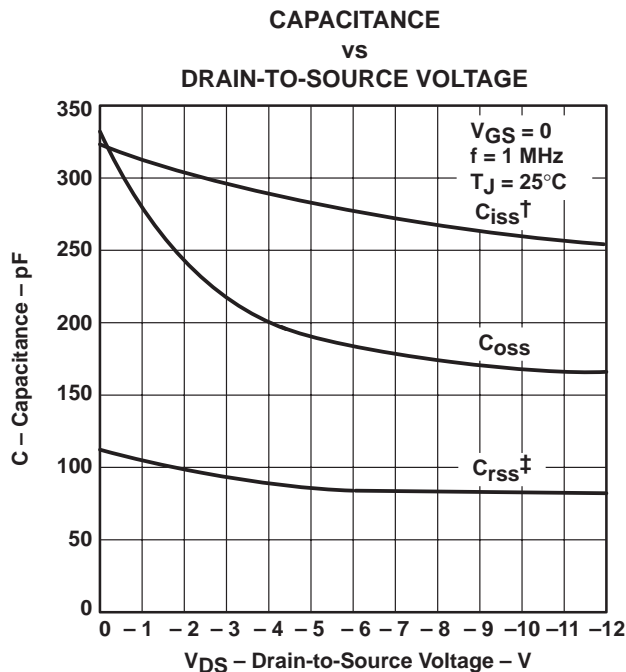

Figure 5



$$\dagger C_{iss} = C_{gs} + C_{gd}, \quad C_{ds(\text{shorted})}$$

$$\ddagger C_{rss} = C_{gd}, \quad C_{oss} = C_{ds} + \frac{C_{gs} C_{gd}}{C_{gs} + C_{gd}} \approx C_{ds} + C_{gd}$$

Figure 6

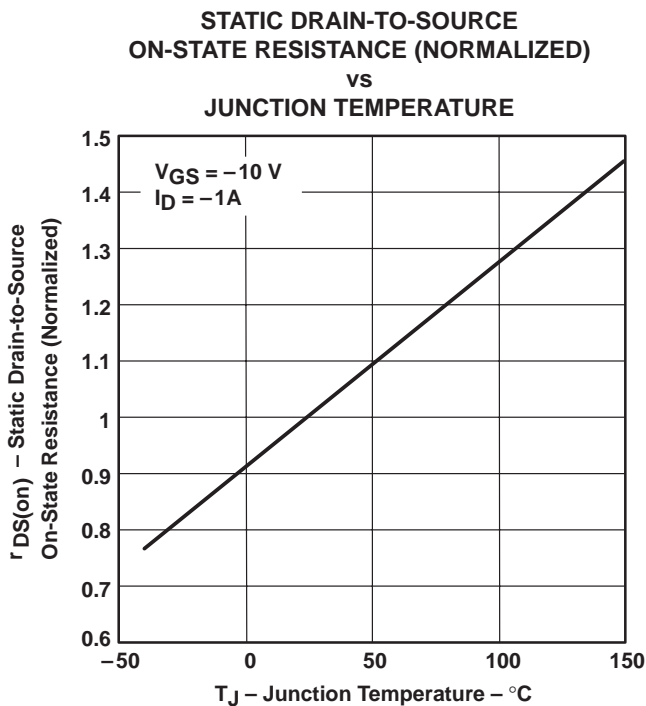

Figure 7

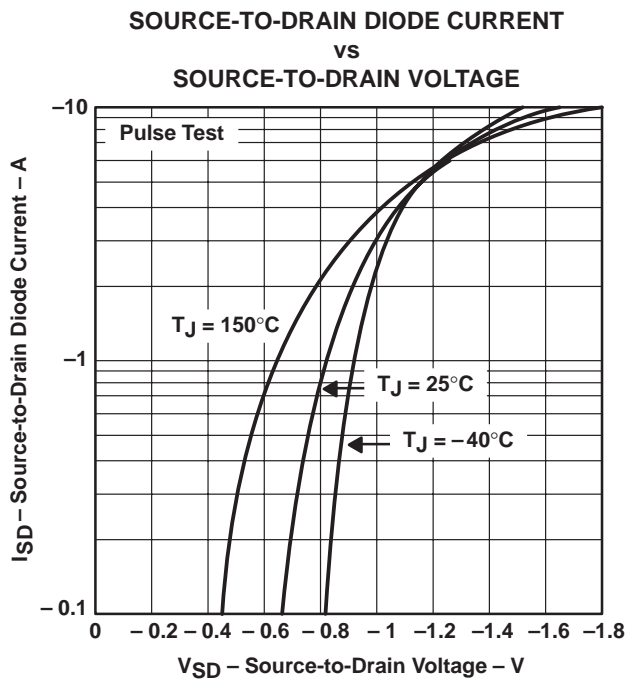

Figure 8

TPS1120, TPS1120Y DUAL P-CHANNEL ENHANCEMENT-MODE MOSFETS

SLVS080A – MARCH 1994 – REVISED AUGUST 1995

TYPICAL CHARACTERISTICS

STATIC DRAIN-TO-SOURCE ON-STATE RESISTANCE
vs
GATE-TO-SOURCE VOLTAGE

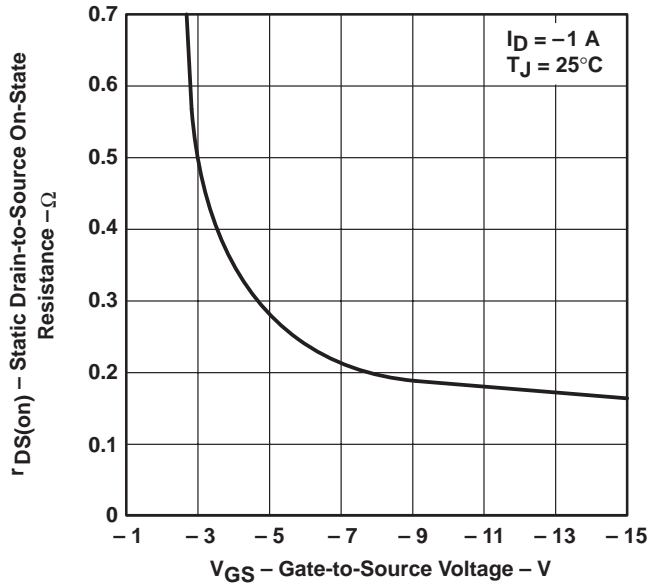

Figure 9

GATE-TO-SOURCE THRESHOLD VOLTAGE
vs
JUNCTION TEMPERATURE

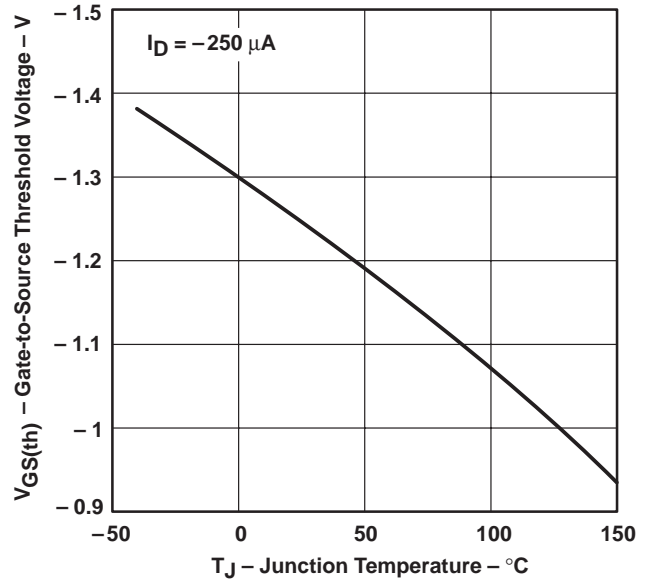

Figure 10

GATE-TO-SOURCE VOLTAGE
vs
GATE CHARGE

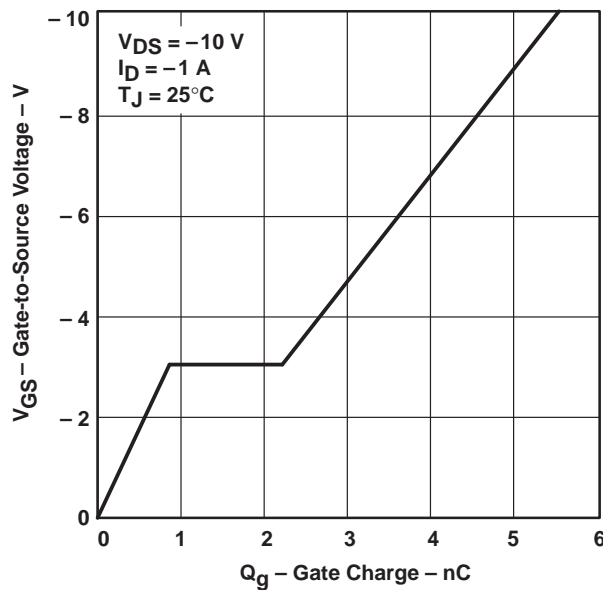
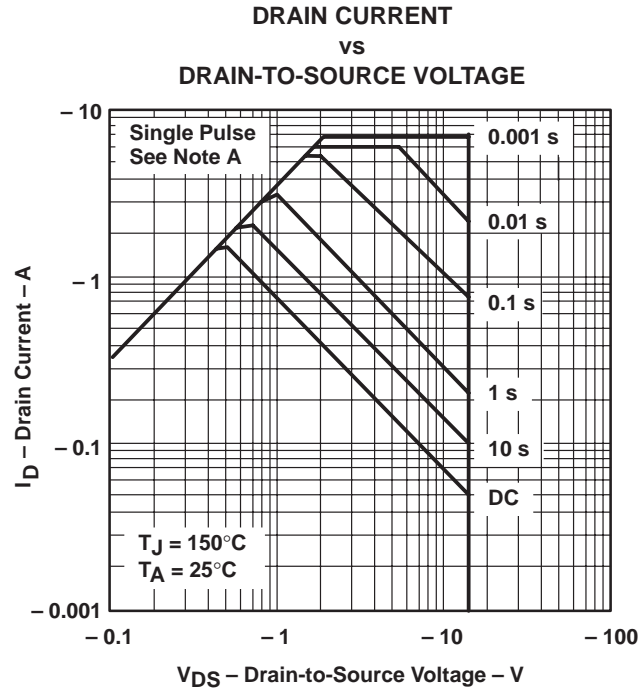

Figure 11



POST OFFICE BOX 655303 • DALLAS, TEXAS 75265

THERMAL INFORMATION



NOTE A: FR4-board-mounted only

Figure 12

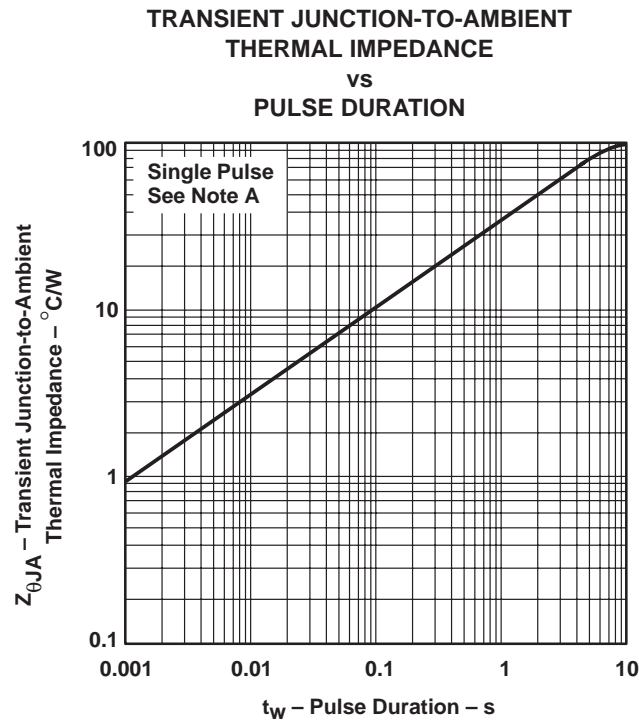

NOTE A: FR4-board-mounted only

Figure 13

TPS1120, TPS1120Y DUAL P-CHANNEL ENHANCEMENT-MODE MOSFETS

SLVS080A – MARCH 1994 – REVISED AUGUST 1995

THERMAL INFORMATION

The profile of the heat sinks used for thermal measurements is shown in Figure 14. Board type is FR4 with 1-oz copper and 1-oz tin/lead (63/37) plate. Use of vias or through-holes to enhance thermal conduction was avoided.

Figure 15 shows a family of $R_{\theta JA}$ curves. The $R_{\theta JA}$ was obtained for various areas of heat sinks while subject to air flow. Power remained fixed at 0.25 W per device or 0.50 W per package. This testing was done at 25°C.

As Figure 14 illustrates, there are two separated heat sinks for each package. Each heat sink is coupled to the lead that is internally tied to a single MOSFET source and is half the total area, as shown in Figure 15. For example, if the total area shown in Figure 15 is 4 cm², each heat sink is 2 cm².

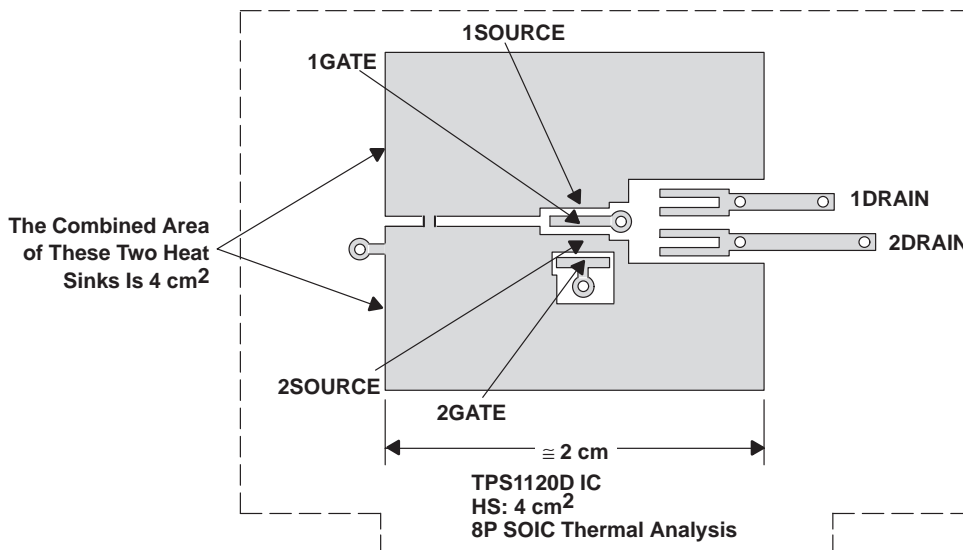

Figure 14. Profile of Heat Sinks

THERMAL RESISTANCE, JUNCTION-TO-AMBIENT vs AIRFLOW, 25°C

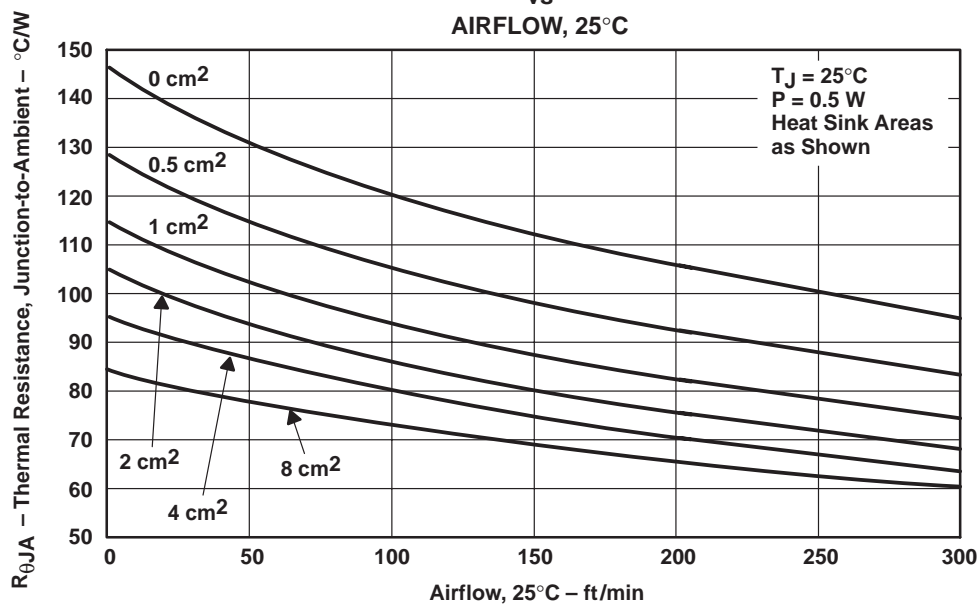

Figure 15

THERMAL INFORMATION

Figure 16 illustrates the thermally enhanced (SO) lead frame. Attaching the two MOSFET dies directly to the source terminals allows maximum heat transfer into a power plane.

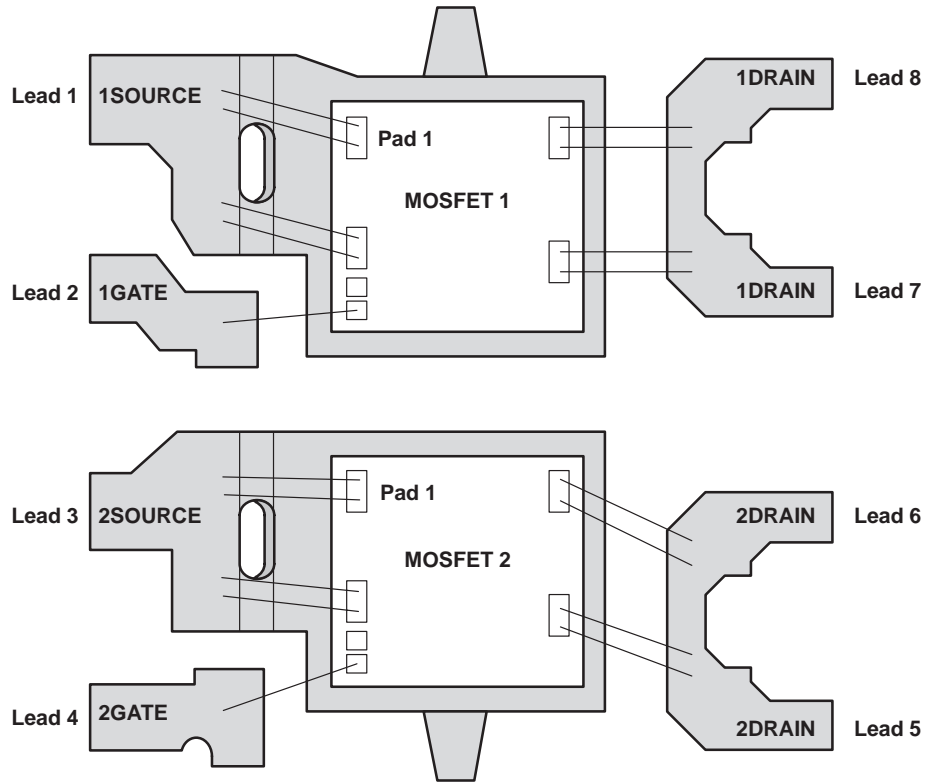

Figure 16. TPS1120 Dual MOSFET SO-8 Lead Frame

APPLICATION INFORMATION

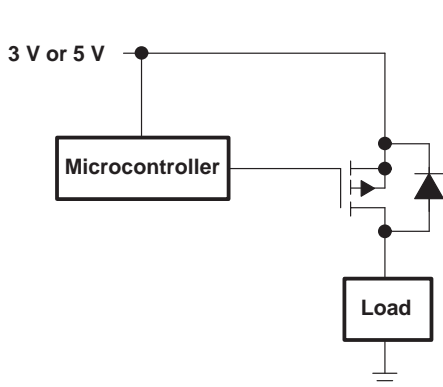

Figure 17. Notebook Load Management

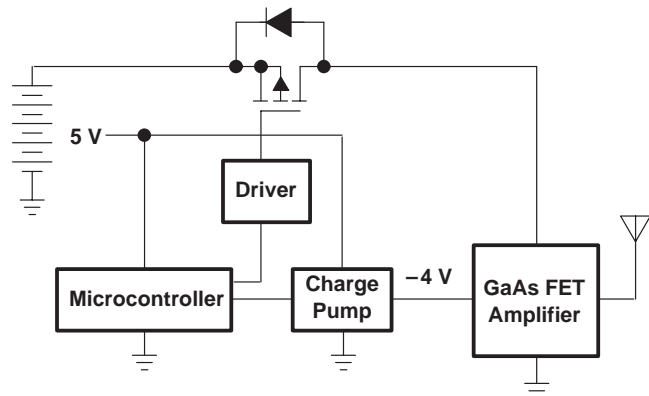

Figure 18. Cellular Phone Output Drive

PACKAGING INFORMATION

| Orderable Device | Status ⁽¹⁾ | Package Type | Package Drawing | Pins | Package Qty | Eco Plan ⁽²⁾ | Lead/Ball Finish | MSL Peak Temp ⁽³⁾ |
|------------------|-----------------------|--------------|-----------------|------|-------------|-------------------------|------------------|------------------------------|
| TPS1120D | ACTIVE | SOIC | D | 8 | 75 | Green (RoHS & no Sb/Br) | CU NIPDAU | Level-1-260C-UNLIM |
| TPS1120DG4 | ACTIVE | SOIC | D | 8 | 75 | Green (RoHS & no Sb/Br) | CU NIPDAU | Level-1-260C-UNLIM |
| TPS1120DR | ACTIVE | SOIC | D | 8 | 2500 | Green (RoHS & no Sb/Br) | CU NIPDAU | Level-1-260C-UNLIM |
| TPS1120DRG4 | ACTIVE | SOIC | D | 8 | 2500 | Green (RoHS & no Sb/Br) | CU NIPDAU | Level-1-260C-UNLIM |

⁽¹⁾ The marketing status values are defined as follows:

ACTIVE: Product device recommended for new designs.

LIFEBUY: TI has announced that the device will be discontinued, and a lifetime-buy period is in effect.

NRND: Not recommended for new designs. Device is in production to support existing customers, but TI does not recommend using this part in a new design.

PREVIEW: Device has been announced but is not in production. Samples may or may not be available.

OBSOLETE: TI has discontinued the production of the device.

⁽²⁾ Eco Plan - The planned eco-friendly classification: Pb-Free (RoHS), Pb-Free (RoHS Exempt), or Green (RoHS & no Sb/Br) - please check <http://www.ti.com/productcontent> for the latest availability information and additional product content details.

TBD: The Pb-Free/Green conversion plan has not been defined.

Pb-Free (RoHS): TI's terms "Lead-Free" or "Pb-Free" mean semiconductor products that are compatible with the current RoHS requirements for all 6 substances, including the requirement that lead not exceed 0.1% by weight in homogeneous materials. Where designed to be soldered at high temperatures, TI Pb-Free products are suitable for use in specified lead-free processes.

Pb-Free (RoHS Exempt): This component has a RoHS exemption for either 1) lead-based flip-chip solder bumps used between the die and package, or 2) lead-based die adhesive used between the die and leadframe. The component is otherwise considered Pb-Free (RoHS compatible) as defined above.

Green (RoHS & no Sb/Br): TI defines "Green" to mean Pb-Free (RoHS compatible), and free of Bromine (Br) and Antimony (Sb) based flame retardants (Br or Sb do not exceed 0.1% by weight in homogeneous material)

⁽³⁾ MSL, Peak Temp. -- The Moisture Sensitivity Level rating according to the JEDEC industry standard classifications, and peak solder temperature.

Important Information and Disclaimer:The information provided on this page represents TI's knowledge and belief as of the date that it is provided. TI bases its knowledge and belief on information provided by third parties, and makes no representation or warranty as to the accuracy of such information. Efforts are underway to better integrate information from third parties. TI has taken and continues to take reasonable steps to provide representative and accurate information but may not have conducted destructive testing or chemical analysis on incoming materials and chemicals. TI and TI suppliers consider certain information to be proprietary, and thus CAS numbers and other limited information may not be available for release.

In no event shall TI's liability arising out of such information exceed the total purchase price of the TI part(s) at issue in this document sold by TI to Customer on an annual basis.

IMPORTANT NOTICE

Texas Instruments Incorporated and its subsidiaries (TI) reserve the right to make corrections, modifications, enhancements, improvements, and other changes to its products and services at any time and to discontinue any product or service without notice. Customers should obtain the latest relevant information before placing orders and should verify that such information is current and complete. All products are sold subject to TI's terms and conditions of sale supplied at the time of order acknowledgment.

TI warrants performance of its hardware products to the specifications applicable at the time of sale in accordance with TI's standard warranty. Testing and other quality control techniques are used to the extent TI deems necessary to support this warranty. Except where mandated by government requirements, testing of all parameters of each product is not necessarily performed.

TI assumes no liability for applications assistance or customer product design. Customers are responsible for their products and applications using TI components. To minimize the risks associated with customer products and applications, customers should provide adequate design and operating safeguards.

TI does not warrant or represent that any license, either express or implied, is granted under any TI patent right, copyright, mask work right, or other TI intellectual property right relating to any combination, machine, or process in which TI products or services are used. Information published by TI regarding third-party products or services does not constitute a license from TI to use such products or services or a warranty or endorsement thereof. Use of such information may require a license from a third party under the patents or other intellectual property of the third party, or a license from TI under the patents or other intellectual property of TI.

Reproduction of information in TI data books or data sheets is permissible only if reproduction is without alteration and is accompanied by all associated warranties, conditions, limitations, and notices. Reproduction of this information with alteration is an unfair and deceptive business practice. TI is not responsible or liable for such altered documentation.

Resale of TI products or services with statements different from or beyond the parameters stated by TI for that product or service voids all express and any implied warranties for the associated TI product or service and is an unfair and deceptive business practice. TI is not responsible or liable for any such statements.

Following are URLs where you can obtain information on other Texas Instruments products and application solutions:

| Products | | Applications | |
|------------------|--|---------------------|--|
| Amplifiers | amplifier.ti.com | Audio | www.ti.com/audio |
| Data Converters | dataconverter.ti.com | Automotive | www.ti.com/automotive |
| DSP | dsp.ti.com | Broadband | www.ti.com/broadband |
| Interface | interface.ti.com | Digital Control | www.ti.com/digitalcontrol |
| Logic | logic.ti.com | Military | www.ti.com/military |
| Power Mgmt | power.ti.com | Optical Networking | www.ti.com/opticalnetwork |
| Microcontrollers | microcontroller.ti.com | Security | www.ti.com/security |
| | | Telephony | www.ti.com/telephony |
| | | Video & Imaging | www.ti.com/video |
| | | Wireless | www.ti.com/wireless |

Mailing Address: Texas Instruments
Post Office Box 655303 Dallas, Texas 75265

Copyright © 2006, Texas Instruments Incorporated