

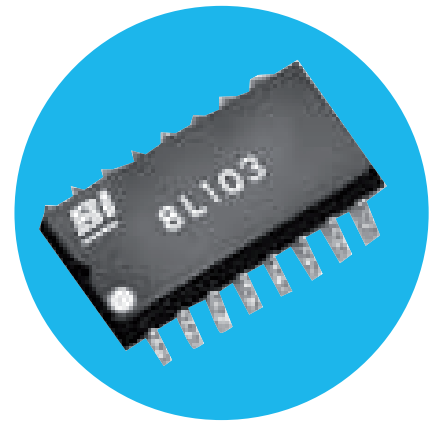

## Model 628 L

### Model 628 L Series

- R/2R Ladder
- .220" Small Outline
- Thick Film DIP
- Surface Mount
- Resistor Networks



 All parts are Pb-free and comply with EU Directive 2011/65/EU (RoHS2)

### Electrical

|  |                                   |
|--|-----------------------------------|
| Standard Resistance Range, Ohms        | 1K to 100K                        |
| Standard Resistance Tolerance, at 25°C | ±2%                               |
| Operating Temperature Range            | -55°C to +125°C                   |
| Temperature Coefficient of Resistance  | ±100ppm/°C                        |
| Maximum Operating Voltage              | 50Vdc or √PR                      |
| Insulation Resistance                  | ≥10,000 Megohms                   |
| Ladder Network Accuracy                | 8 Bits: ±1/2 LSB, -55°C to +125°C |

### Mechanical

|                    |  |
|--------------------|--|
| Lead Material      | Copper Alloy, 96.5 / 3.5 SnAg (Dipped) |
| Lead Configuration | Gull Wing                              |
| Lead Coplanarity   | ±0.002 in. (0.057mm)                   |
| Substrate Material | Alumina                                |
| Resistor Material  | Cermet                                 |
| Body Material      | Epoxy                                  |

### Applicable Documents

|   |
|---|
| MIL-R-914 — Resistor Networks, Fixed, Film, Surface Mount Established Reliability General Specification |
| MIL-STD-202 — Test Methods for Electronic and Electrical Component Parts                                |
| EIA-481 — Carrier Taping of Surface Mount Components for Automatic Handling                             |
| EIA-PDP-100 — SOGN-0002 Outline Dimensions  |

Specifications subject to change without notice.

#### General Note

TT Electronics reserves the right to make changes in product specification without notice or liability. All information is subject to TT Electronics' own data and is considered accurate at time of going to print.

Model 628 L Series

### Outline Dimensions (Inch/mm)

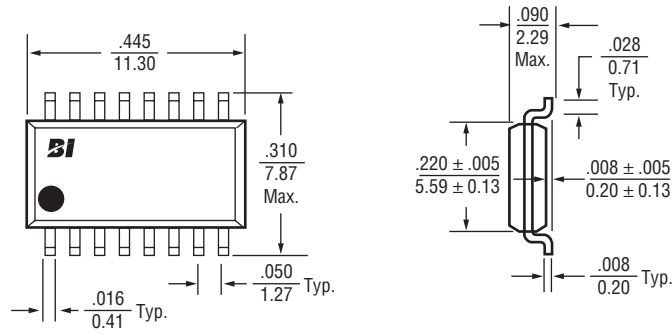

Note: Maximum Allowable Mold Excursion = 0.006"

### Schematics

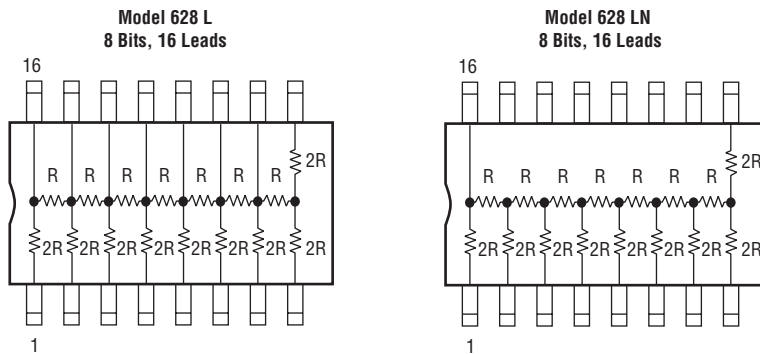

Note: Custom circuits are available. Consult factory.

**General Note**

TT Electronics reserves the right to make changes in product specification without notice or liability. All information is subject to TT Electronics' own data and is considered accurate at time of going to print.

Model 628 L Series

### Solder Pad Layout (Inch/mm)

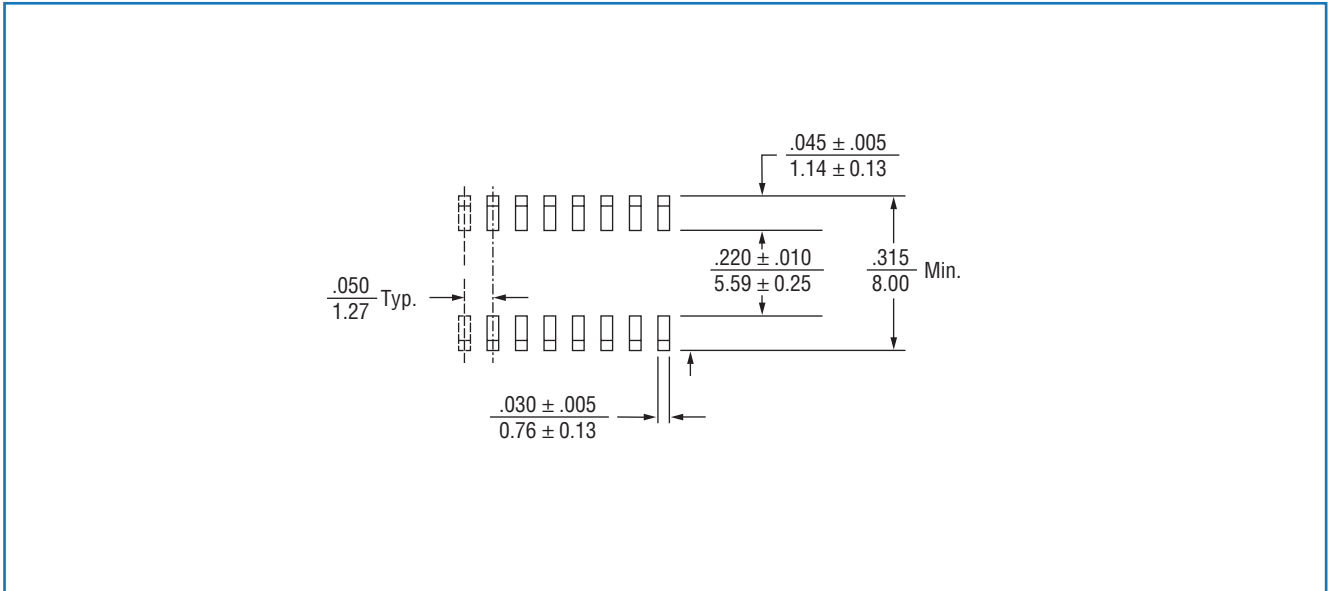

### Power Derating Curve

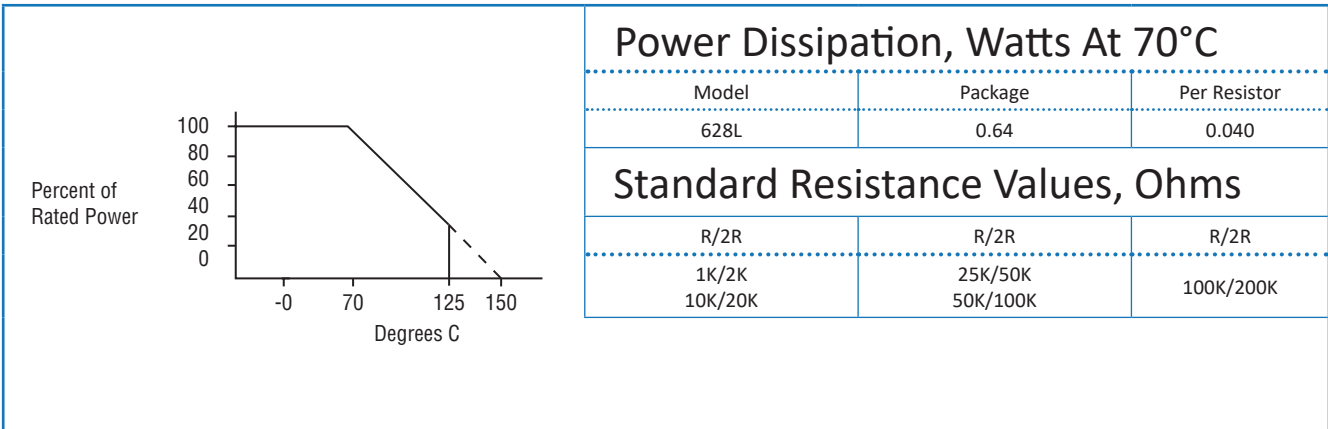

### Typical Part Marking

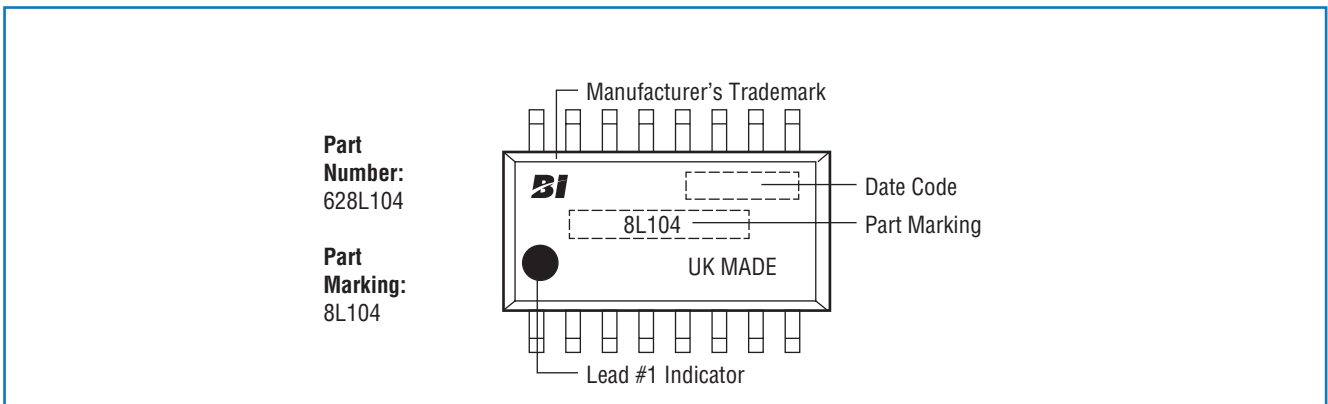

**General Note**

TT Electronics reserves the right to make changes in product specification without notice or liability. All information is subject to TT Electronics' own data and is considered accurate at time of going to print.

Model 628 L Series

## Packaging

|           |  |                              |  |
|-----------|--|------------------------------|--|
| Standard: | Tape & Reel<br>Conforms to requirements of EIA-481.<br>All units oriented with lead #1 to the left of direction of feed. |                              |  |
| Tape      | Width =  | 24mm                         |  |
|           | Pocket =   | Embossed Plastic, Antistatic |  |
|           | Pitch =  | 12mm                         |  |
| Reel      | Diameter =   | 13" (330mm) Maximum          |  |
|           | Capacity =   | 2,000 Units                  |  |
| Option:   | Magazines<br>Conforms to EIA and JEDEC standards.<br>All units oriented with lead #1 to the same side.                   |                              |  |
| Magazine: | Capacity =   | 50 Units                     |  |

## Ordering Information

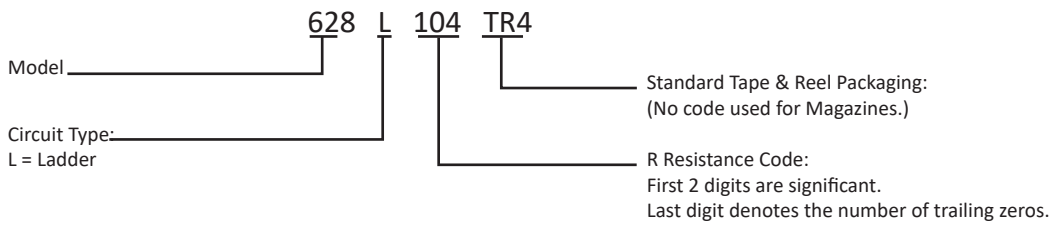

**General Note**

TT Electronics reserves the right to make changes in product specification without notice or liability.  
All information is subject to TT Electronics' own data and is considered accurate at time of going to print.