

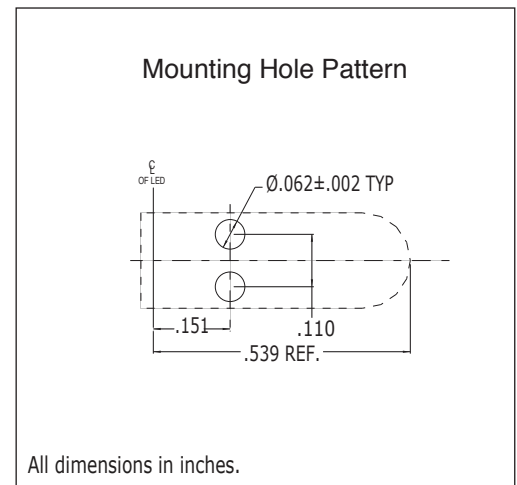

**7511G Series**  
**Light Pipe 0.565" Length**  
**Polycarbonate UL94 V-0**

**7511 Series Bright Pipes™ Optical Lightpipes**

**Descriptions and Features**

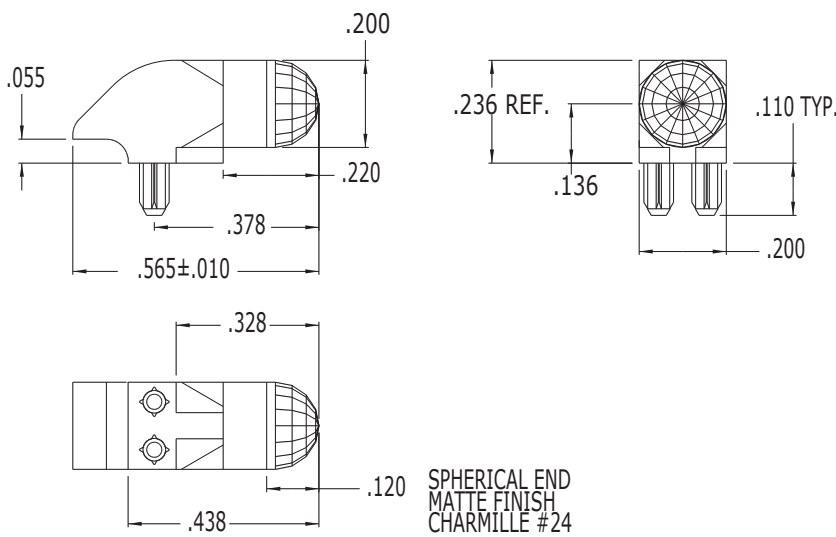

All dimensions in inches.

All dimensions in inches.

- Precision engineered with ray tracing for bright, optically precise even indication and attractive appearance.
- ESD protection from circuitry for exceptional reliability.
- High contrast and wide viewing angle for greater visibility.
- Available in a variety of colors for added contrast and aesthetics.
- Parts inserted after reflow to permit LED pad inspection before assembly.
- Compliance to UL94 V-0.
- Low profile for height constrained applications.
- Large lens provides high visibility.
- 7511G Series designed for use with 7012X SMT LED.

Color	Part Number
Red	7511G1
Clear Transparent	7511G2C
Green	7511G5
Yellow	7511G7

**Compliance and Approvals**

