

NOTES:

- 1) FINISH: Parts shall have a smooth appearance, min. 600 surface finish, with no gates and all flash removed
- 2) U.S. & Foreign Pat. Issued and Pend.

REVISIONS				
ECN #	REV	DESCRIPTION	DATE	INITIALS
	N/A	INITIAL RELEASE	10/25/85	JS
	001	REVISED PER ECR111009AZ01	2/8/10	KH

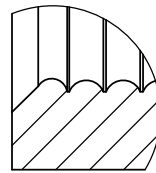
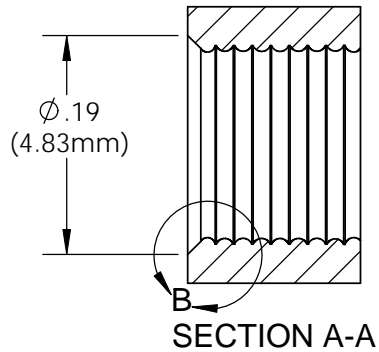
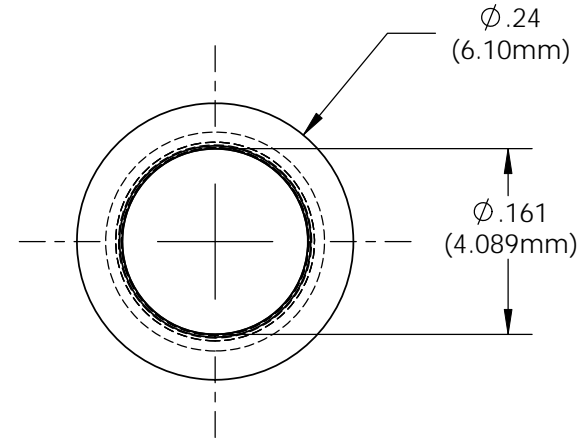
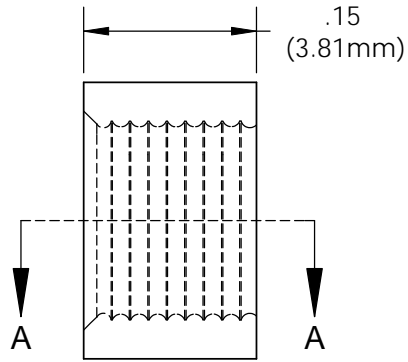

**DETAIL B
SCALE 12 : 1**



**ISOMETRIC VIEW
SCALE 4:1**

<small>UNLESS OTHERWISE SPECIFIED DIMENSIONS ARE IN INCHES: ANGLES DECIMALS ± 1' .X ±.020 .XX ±.010 FINISH .XXX ±.005 BREAK ALL CORNERS AND SHARP EDGES .050 MAX</small>	MATERIAL Polypropylene UL 94-HB		VISUAL COMMUNICATIONS COMPANY 190 Bosstick Boulevard, Suite 101 San Marcos, CA 92069 USA Phone (760) 560-1300 Fax (760) 560-1301 email vccsales@vcclite.com		
	FINISH SEE NOTES		TITLE: CLIPLITE RNG 165		
<small>THIRD ANGLE PROJECTION</small>	APPROVALS	DATE	SIZE A	DWG. NO. RNG 165	REV 001
	DRAWN K.HOWARD	2/8/10	CHECKED DPZ	SCALE: 6:1	SHEET 1 OF 1
<small>PROPRIETARY AND CONFIDENTIAL THE INFORMATION CONTAINED IN THIS DRAWING IS THE SOLE PROPERTY OF VISUAL COMMUNICATIONS COMPANY, INC. ANY REPRODUCTION IN PART OR AS A WHOLE WITHOUT THE WRITTEN PERMISSION OF VISUAL COMMUNICATIONS COMPANY, INC IS PROHIBITED.</small>			DO NOT SCALE DRAWING		