

## Quad Complementary CMOS Analog Switch

### FEATURES

- $\pm 22\text{-V}$  Supply Voltage Rating
- TTL and CMOS Compatible Logic
- Low On-Resistance— $r_{DS(on)}$ :  $45\ \Omega$
- Low Leakage— $I_{D(on)}$ :  $20\ \text{pA}$
- Single Supply Operation Possible
- Extended Temperature Range
- Fast Switching— $t_{ON}$ :  $85\ \text{ns}$

### BENEFITS

- Low Charge Injection— $Q$ :  $1\ \text{pC}$
- Wide Analog Signal Range
- Simple Logic Interface
- Higher Accuracy
- Minimum Transients
- Reduced Power Consumption
- Low Cost

### APPLICATIONS

- Industrial Instrumentation
- Test Equipment
- Communications Systems
- Computer Peripherals
- Portable Instruments
- Sample-and-Hold Circuits

### DESCRIPTION

The versatile DG213 analog switch has two NC and two NO switches. It can be used in various configurations, including four single-pole single-throw (SPST), two single-pole double-throw (SPDT), one "T" switch, one DPDT, etc. This device is fabricated in a Vishay Siliconix' proprietary high-voltage silicon gate CMOS process, resulting in lower on-resistance, lower leakage, higher speed, and lower power consumption.

This analog switch was designed for a wide variety of general purpose applications in telecommunications, instrumentation, process control, computer peripherals, etc. An improved charge

injection compensation design minimizes switching transients. These switches can handle up to  $\pm 22\ \text{V}$ , and have an improved continuous current rating of  $30\ \text{mA}$ . An epitaxial layer prevents latchup.

All switches feature true bi-directional performance in the on condition, and will block signals to the supply levels in the off condition.

For additional information, please refer to Application Note AN208 (FaxBack document #70606).

### FUNCTIONAL BLOCK DIAGRAM AND PIN CONFIGURATION

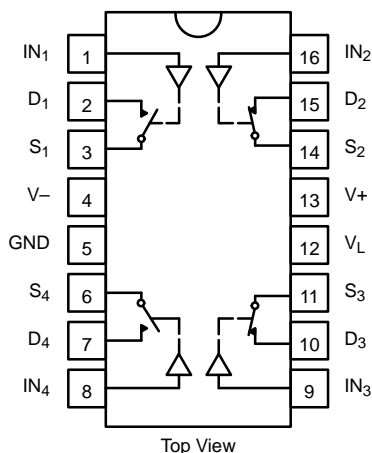

TRUTH TABLE		
Logic	SW <sub>1</sub> , SW <sub>4</sub>	SW <sub>2</sub> , SW <sub>3</sub>
0	OFF	ON
1	ON	OFF

Logic "0"  $\leq 0.8\ \text{V}$   
 Logic "1"  $\geq 2.4\ \text{V}$

ORDERING INFORMATION		
Temp Range	Package	Part Number
-40 to 85°C	16-Pin Plastic DIP	DG213DJ
	16-Pin Narrow SOIC	DG213DY
	16-Pin TSSOP	DG213DQ



**ABSOLUTE MAXIMUM RATINGS**

Voltages Referenced to V-

V+ ..... 44 V

GND ..... 25 V

Digital Inputs<sup>a</sup> V<sub>S</sub>, V<sub>D</sub> ..... (V-) -2 V to (V+) +2 V  
or 30 mA, whichever occurs first

Current, Any Terminal ..... 30 mA

Peak Current, S or D  
(Pulsed at 1 ms, 10% duty cycle max) ..... 100 mA

Storage Temperature ..... -65 to 125°C

Power Dissipation (Package)<sup>b</sup>

16-Pin Plastic DIP<sup>c</sup> ..... 470 mW

16-Pin Narrow SOIC<sup>d</sup> ..... 640 mW

16-Pin TSSOP<sup>d</sup> ..... 500 mW

- Notes:
- Signals on S<sub>X</sub>, D<sub>X</sub>, or IN<sub>X</sub> exceeding V+ or V- will be clamped by internal diodes. Limit forward diode current to maximum current ratings.
  - All leads welded or soldered to PC Board.
  - Derate 6.5 mW/°C above 75°C
  - Derate 7.6 mW/°C above 75°C

SPECIFICATIONS							
Parameter	Symbol	Test Conditions Unless Otherwise Specified V+ = 15 V, V- = -15 V V <sub>L</sub> = 5 V, V <sub>IN</sub> = 2.4 V, 0.8 V <sup>e</sup>	Temp <sup>a</sup>	D Suffix -40 to 85°C			Unit
				Min <sup>c</sup>	Typ <sup>b</sup>	Max <sup>c</sup>	
<b>Analog Switch</b>							
Analog Signal Range <sup>d</sup>	V <sub>ANALOG</sub>		Full	V-		V+	V
Drain-Source On-Resistance	r <sub>DS(on)</sub>	V <sub>D</sub> = ±10 V, I <sub>S</sub> = 1 mA	Room		45	60	Ω
r <sub>DS(on)</sub> Match	Δr <sub>DS(on)</sub>		Room		1	2	
Source Off Leakage Current	I <sub>S(off)</sub>	V <sub>S</sub> = ±14 V, V <sub>D</sub> = ∓14 V	Room	-0.5	±0.01	0.5	nA
Drain Off Leakage Current	I <sub>D(off)</sub>	V <sub>D</sub> = ±14 V, V <sub>S</sub> = ∓14 V	Room	-0.5	±0.01	0.5	
Drain On Leakage Current	I <sub>D(on)</sub>	V <sub>S</sub> = V <sub>D</sub> = 14 V	Room	-0.5	±0.02	0.5	
<b>Digital Control</b>							
Input Voltage High	V <sub>INH</sub>		Full	2.4			V
Input Voltage Low	V <sub>INL</sub>		Full			0.8	
Input Current	I <sub>INH</sub> or I <sub>INL</sub>	V <sub>INH</sub> or V <sub>INL</sub>	Full	-1		1	μA
Input Capacitance	C <sub>IN</sub>		Room		5		pF
<b>Dynamic Characteristics</b>							
Turn-On Time	t <sub>ON</sub>	V <sub>S</sub> = 10 V See Figure 2	Room		85	130	ns
Turn-Off Time	t <sub>OFF</sub>		Room		55	100	
Break-Before-Make Time Delay	t <sub>D</sub>	V <sub>S</sub> = 10 V, See Figure 3	Room	15	25		
Charge Injection	Q	C <sub>L</sub> = 1000 pF, V <sub>g</sub> = 0 V, R <sub>g</sub> = 0 Ω	Room		1		pC
Source-Off Capacitance	C <sub>S(off)</sub>	V <sub>S</sub> = 0 V, f = 1 MHz	Room		5		pF
Drain-Off Capacitance	C <sub>D(off)</sub>		Room		5		
Channel On Capacitance	C <sub>D(on)</sub>	V <sub>D</sub> = V <sub>S</sub> = 0 V, f = 1 MHz	Room		16		
Off Isolation	OIRR	C <sub>L</sub> = 15 pF, R <sub>L</sub> = 50 Ω V <sub>S</sub> = 1 V <sub>RMS</sub> , f = 100 kHz	Room		90		dB
Channel-to-Channel Crosstalk	X <sub>TALK</sub>		Room		95		



SPECIFICATIONS							
Parameter	Symbol	Test Conditions Unless Otherwise Specified $V_+ = 15\text{ V}$ , $V_- = -15\text{ V}$ $V_L = 5\text{ V}$ , $V_{IN} = 2.4\text{ V}$ , $0.8\text{ V}^e$	Temp <sup>a</sup>	D Suffix -40 to 85°C			Unit
				Min <sup>c</sup>	Typ <sup>b</sup>	Max <sup>c</sup>	
<b>Power Supply</b>							
Positive Supply Current	I+	$V_{IN} = 0\text{ or }5\text{ V}$	Room Full			1 5	$\mu\text{A}$
Negative Supply Current	I-		Room Full	-1 -5			
Logic Supply Current	I <sub>L</sub>		Room Full			1 5	
Power Supply Range for Continuous Operation	V <sub>OP</sub>		Full	±3		±22	V

SPECIFICATIONS FOR UNIPOLAR SUPPLY							
Parameter	Symbol	Test Conditions Unless Otherwise Specified $V_+ = 12\text{ V}$ , $V_- = 0\text{ V}$ $V_L = 5\text{ V}$ , $V_{IN} = 2.4\text{ V}$ , $0.8\text{ V}^e$	Temp <sup>a</sup>	D Suffix -40 to 85°C			Unit
				Min <sup>c</sup>	Typ <sup>b</sup>	Max <sup>c</sup>	
<b>Analog Switch</b>							
Analog Signal Range <sup>d</sup>	V <sub>ANALOG</sub>		Full	V-		V+	V
Drain-Source On-Resistance	r <sub>DS(on)</sub>	$V_D = 3\text{ V}$ , $8\text{ V}$ , $I_S = 1\text{ mA}$	Room Full		90	110 140	$\Omega$
<b>Dynamic Characteristics</b>							
Turn-On Time	t <sub>ON</sub>	See Figure 2	Room		125	200	ns
Turn-Off Time	t <sub>OFF</sub>		Room		45	100	
Break-Before-Make Time Delay	t <sub>D</sub>	$V_S = 8\text{ V}$ , See Figure 3	Room	50	80		
Charge Injection	Q	$C_L = 1\text{ nF}$ , $V_{gen} = 6\text{ V}$ , $R_{gen} = 0\ \Omega$	Room		4		pC
<b>Power Supply</b>							
Positive Supply Current	I+	$V_{IN} = 0\text{ or }5\text{ V}$	Room Full			1 5	$\mu\text{A}$
Negative Supply Current	I-		Room Full	-1 -5			
Logic Supply Current	I <sub>L</sub>		Room Full			1 5	
Power Supply Range for Continuous Operation	V <sub>OP</sub>		Full	+3		+40	V

Notes:

- a. Room = 25°C, Full = as determined by the operating temperature suffix.
- b. Typical values are for DESIGN AID ONLY, not guaranteed nor subject to production testing.
- c. The algebraic convention whereby the most negative value is a minimum and the most positive a maximum, is used in this data sheet.
- d. Guaranteed by design, not subject to production test.
- e. V<sub>IN</sub> = input voltage to perform proper function.



**TYPICAL CHARACTERISTICS (25°C UNLESS NOTED)**

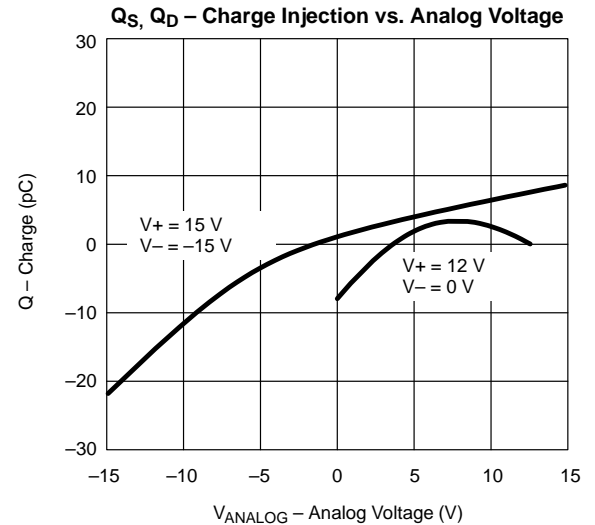
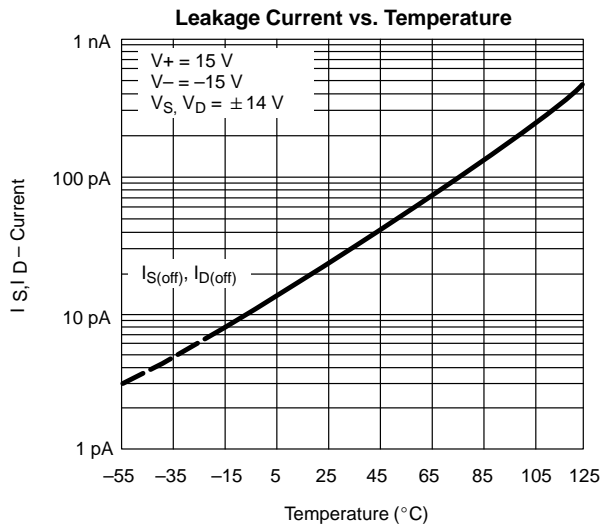
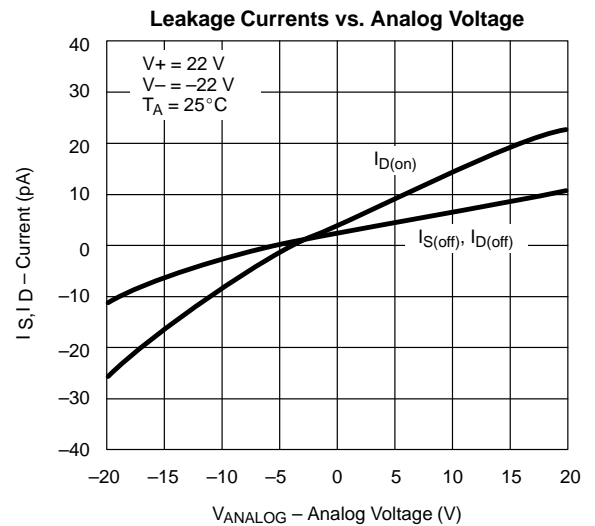
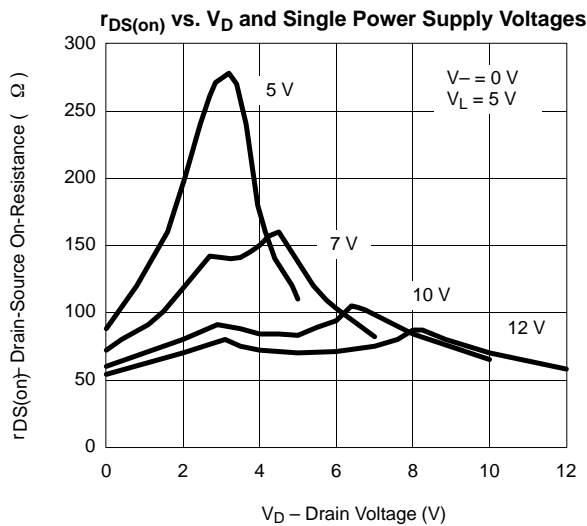
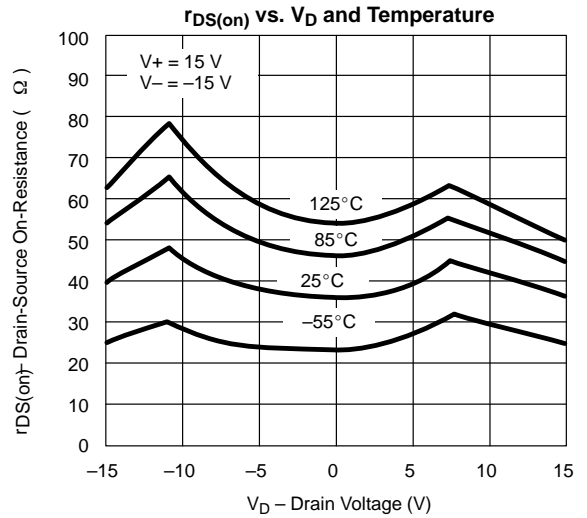
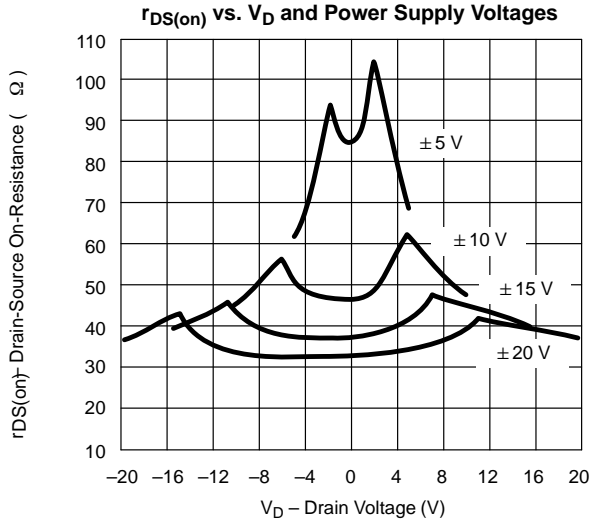

**TYPICAL CHARACTERISTICS (25°C UNLESS NOTED)**

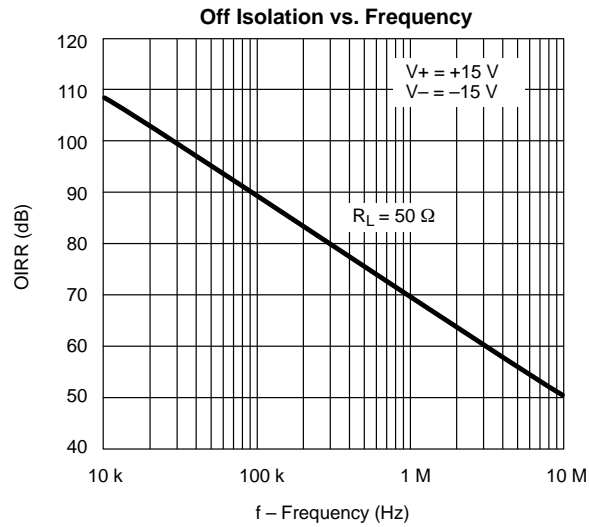

**SCHEMATIC DIAGRAM (TYPICAL CHANNEL)**

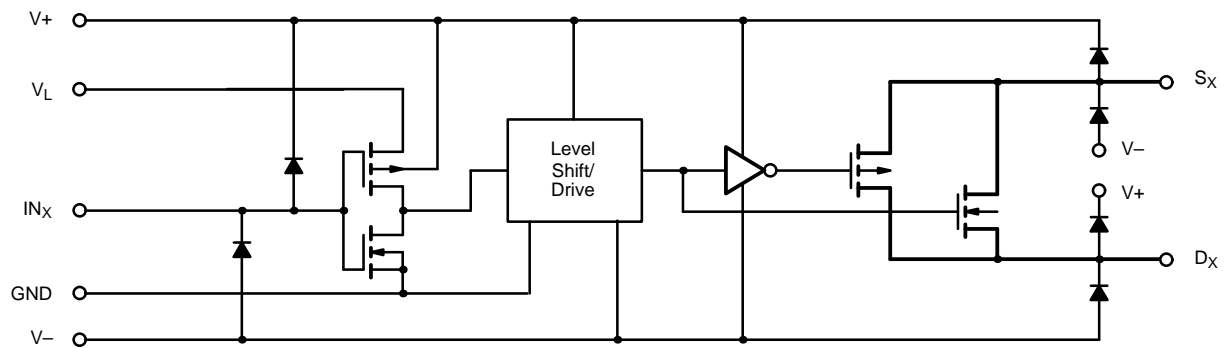

FIGURE 1.

**TEST CIRCUITS**

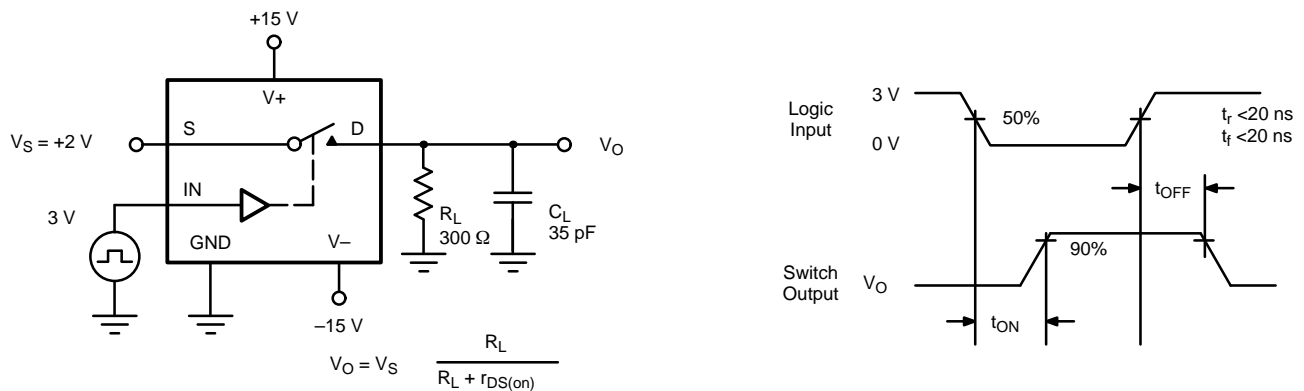
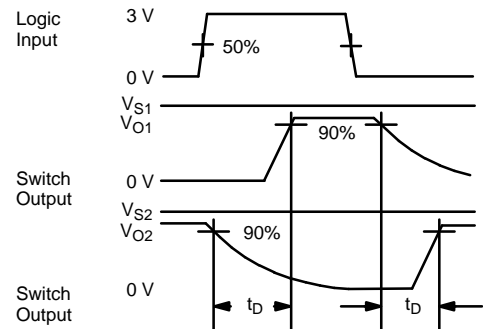
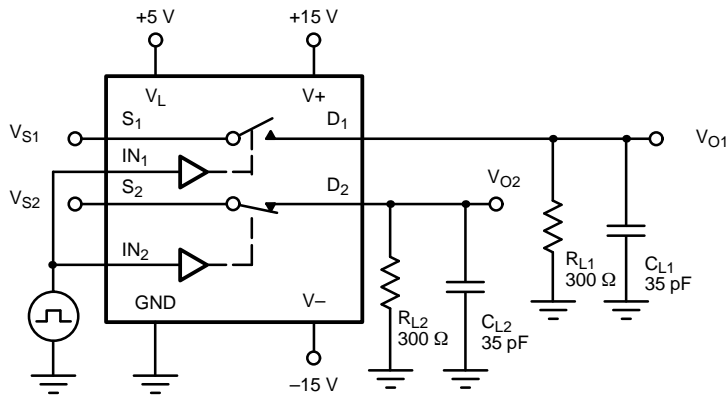

FIGURE 2. Switching Time

**TEST CIRCUITS**



$C_L$  (includes fixture and stray capacitance)

**FIGURE 3.** Break-Before-Make

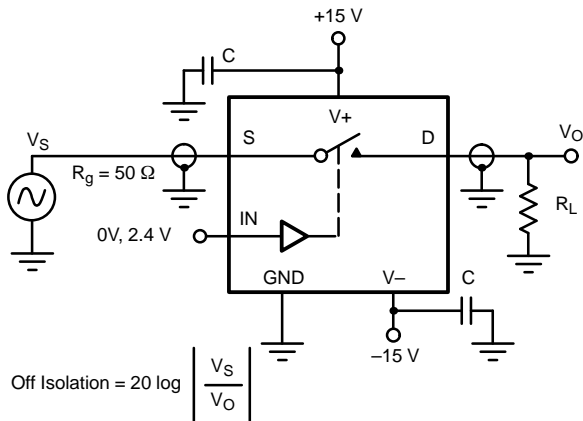

$$\text{Off Isolation} = 20 \log \left| \frac{V_S}{V_O} \right|$$

**FIGURE 4.** Off Isolation

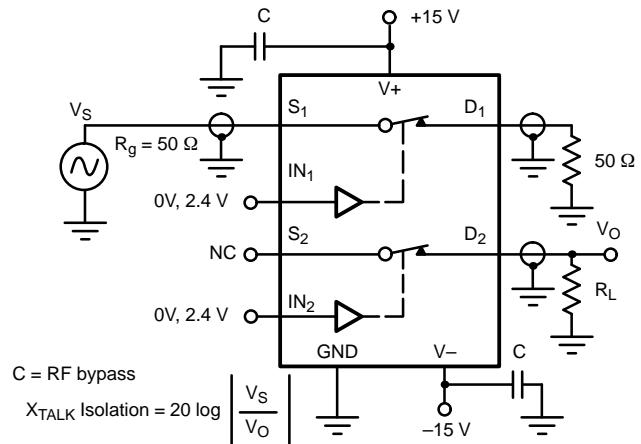

$C = \text{RF bypass}$   
 $X_{\text{TALK}} \text{ Isolation} = 20 \log \left| \frac{V_S}{V_O} \right|$

**FIGURE 5.** Channel-to-Channel Crosstalk

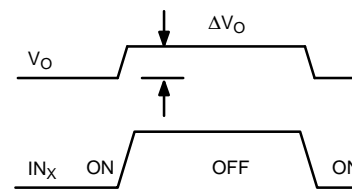
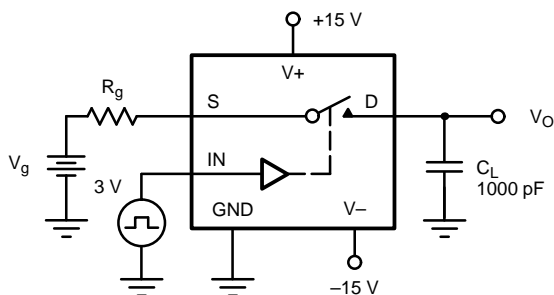

$\Delta V_O$  = measured voltage error due to charge injection  
 The charge injection in coulombs is  $Q = C_L \times \Delta V_O$

**FIGURE 6.** Charge Injection

**APPLICATIONS**

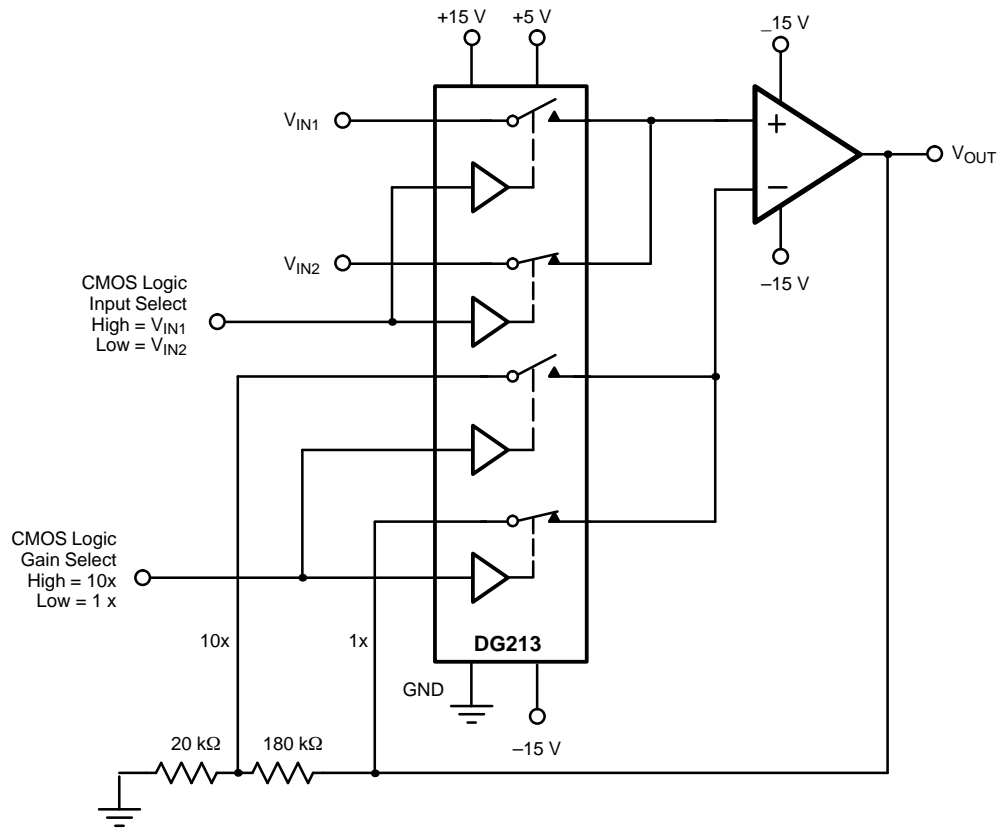

**FIGURE 7.** Low Power Non-Inverting Amplifier with Digitally Selectable Inputs and Gain



## Notice

Specifications of the products displayed herein are subject to change without notice. Vishay Intertechnology, Inc., or anyone on its behalf, assumes no responsibility or liability for any errors or inaccuracies.

Information contained herein is intended to provide a product description only. No license, express or implied, by estoppel or otherwise, to any intellectual property rights is granted by this document. Except as provided in Vishay's terms and conditions of sale for such products, Vishay assumes no liability whatsoever, and disclaims any express or implied warranty, relating to sale and/or use of Vishay products including liability or warranties relating to fitness for a particular purpose, merchantability, or infringement of any patent, copyright, or other intellectual property right.

The products shown herein are not designed for use in medical, life-saving, or life-sustaining applications. Customers using or selling these products for use in such applications do so at their own risk and agree to fully indemnify Vishay for any damages resulting from such improper use or sale.