

Precision CMOS Analog Switches

DESCRIPTION

The DG417/418/419 monolithic CMOS analog switches were designed to provide high performance switching of analog signals. Combining low power, low leakages, high speed, low on-resistance and small physical size, the DG417 series is ideally suited for portable and battery powered industrial and military applications requiring high performance and efficient use of board space.

To achieve high-voltage ratings and superior switching performance, the DG417 series is built on Vishay Siliconix's high voltage silicon gate (HVSG) process. Break-before-make is guaranteed for the DG419, which is an SPDT configuration. An epitaxial layer prevents latchup.

Each switch conducts equally well in both directions when on, and blocks up to the power supply level when off.

The DG417 and DG418 respond to opposite control logic levels as shown in the Truth Table.

FEATURES

- ± 15 V Analog Signal Range
- On-Resistance - $r_{DS(on)}$: 20 Ω
- Fast Switching Action - t_{ON} : 100 ns
- Ultra Low Power Requirements - P_D : 35 nW
- TTL and CMOS Compatible
- MiniDIP and SOIC Packaging
- 44 V Supply Max Rating

RoHS*
 COMPLIANT

BENEFITS

- Wide Dynamic Range
- Low Signal Errors and Distortion
- Break-Before-Make Switching Action
- Simple Interfacing
- Reduced Board Space
- Improved Reliability

APPLICATIONS

- Precision Test Equipment
- Precision Instrumentation
- Battery Powered Systems
- Sample-and-Hold Circuits
- Military Radios
- Guidance and Control Systems
- Hard Disk Drives

FUNCTIONAL BLOCK DIAGRAM AND PIN CONFIGURATION

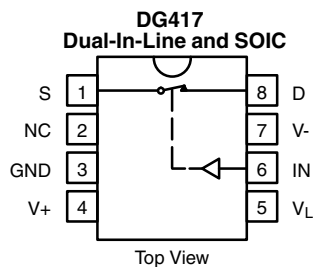

TRUTH TABLE		
Logic	DG417	DG418
0	ON	OFF
1	OFF	ON

 Logic "0" ≤ 0.8 V

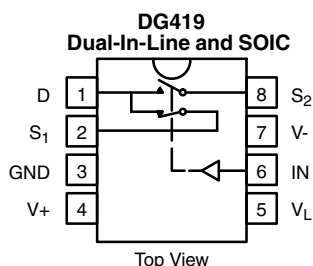
 Logic "1" ≥ 2.4 V

TRUTH TABLE - DG419		
Logic	SW ₁	SW ₂
0	ON	OFF
1	OFF	ON

 Logic "0" ≤ 0.8 V

 Logic "1" ≥ 2.4 V

* Pb containing terminations are not RoHS compliant, exemptions may apply



ORDERING INFORMATION		
Temp Range	Package	Part Number
DG417/DG418		
- 40 to 85 °C	8-Pin Plastic MiniDIP	DG417DJ DG417DJ-E3
		DG418DJ DG418DJ-E3
	8-Pin Narrow SOIC	DG417DY DG417DY-E3 DG417DY-T1 DG417DY-T1-E3
		DG418DY DG418DY-E3 DG418DY-T1 DG418DY-T1-E3
DG419		
- 40 to 85 °C	8-Pin Plastic MiniDIP	DG419DJ DG419DJ-E3
	8-Pin Narrow SOIC	DG419DY DG419DY-E3 DG419DY-T1 DG419DY-T1-E3

ABSOLUTE MAXIMUM RATINGS			
Parameter	Limit	Unit	
Voltages Referenced V+ to V-	44	V	
GND	25		
V _L	(GND - 0.3) to (V+) + 0.3		
Digital Inputs ^a , V _S , V _D	(V-) - 2 to (V+) + 2 or 30 mA, whichever occurs first		
Current, (Any Terminal) Continuous	30	mA	
Current, S or D (Pulsed at 1 ms, 10 % duty cycle)	100		
Storage Temperature	(AK Suffix)	- 65 to 150	°C
	(DJ, DY Suffix)	- 65 to 125	
Power Dissipation (Package) ^b	8-Pin Plastic MiniDIP ^c	400	mW
	8-Pin Narrow SOIC ^d	400	
	8-Pin CerDIP ^e	600	

Notes:

- a. Signals on S_X, D_X, or IN_X exceeding V+ or V- will be clamped by internal diodes. Limit forward diode current to maximum current ratings.
- b. All leads welded or soldered to PC Board.
- c. Derate 6 mW/°C above 75 °C.
- d. Derate 6.5 mW/°C above 75 °C.
- e. Derate 12 mW/°C above 75 °C.

SCHEMATIC DIAGRAM (TYPICAL CHANNEL)

Figure 1.

SPECIFICATIONS^a										
Parameter	Symbol	Test Conditions Unless Otherwise Specified $V_+ = 15\text{ V}$, $V_- = -15\text{ V}$ $V_L = 5\text{ V}$, $V_{IN} = 2.4\text{ V}$, 0.8 V^f	Temp ^b	Typ ^c	A Suffix - 55 to 125 °C		D Suffix - 40 to 85 °C		Unit	
					Min ^d	Max ^d	Min ^d	Max ^d		
Analog Switch										
Analog Signal Range ^e	V_{ANALOG}		Full		- 15	15	- 15	15	V	
Drain-Source On-Resistance	$r_{DS(on)}$	$I_S = -10\text{ mA}$, $V_D = \pm 12.5\text{ V}$ $V_+ = 13.5\text{ V}$, $V_- = -13.5\text{ V}$	Room Full	20		35 45		35 45	Ω	
Switch Off Leakage Current	$I_{S(off)}$	$V_+ = 16.5\text{ V}$, $V_- = -16.5\text{ V}$ $V_D = \pm 15.5\text{ V}$ $V_S = \pm 15.5\text{ V}$	Room Full	- 0.1	- 0.25 - 20	0.25 20	- 0.25 - 5	0.25 5	nA	
	$I_{D(off)}$		DG417 DG418	Room Full	- 0.1	- 0.25 - 20	0.25 20	- 0.25 - 5		0.25 5
			DG419	Room Full	- 0.1	- 0.75 - 60	0.75 60	- 0.75 - 12		0.75 12
Channel Off Leakage Current	$I_{D(on)}$	$V_+ = 16.5\text{ V}$, $V_- = -16.5\text{ V}$ $V_S = V_D = \pm 15.5\text{ V}$	DG417 DG418 DG419	Room Full	- 0.4 - 40 - 60	0.4 40 60	- 0.4 - 10 - 12	0.4 10 12		
Digital Control										
Input Current V_{IN} Low	I_{IL}		Full	0.005	- 0.5	0.5	- 0.5	0.5	μA	
Input Current V_{IN} High	I_{IH}		Full	0.005	- 0.5	0.5	- 0.5	0.5		
Dynamic Characteristics										
Turn-On Time	t_{ON}	$R_L = 300\ \Omega$, $C_L = 35\text{ pF}$ $V_S = \pm 10\text{ V}$ See Switching Time Test Circuit	DG417 DG418	Room Full	100		175 250		175 250	ns
Turn-Off Time	t_{OFF}		DG417 DG418	Room Full	60		145 210		145 210	
Transition Time	t_{TRANS}	$R_L = 300\ \Omega$, $C_L = 35\text{ pF}$ $V_{S1} = \pm 10\text{ V}$, $V_{S2} = \pm 10\text{ V}$	DG419	Room Full			175 250		175 250	
Break-Before-Make Time Delay (DG403)	t_D	$R_L = 300\ \Omega$, $C_L = 35\text{ pF}$ $V_{S1} = V_{S2} = \pm 10\text{ V}$	DG419	Room	13	5		5		
Charge Injection	Q	$C_L = 10\text{ nF}$, $V_{gen} = 0\text{ V}$, $R_{gen} = 0\ \Omega$		Room	60					pC
Source Off Capacitance	$C_{S(off)}$	$f = 1\text{ MHz}$, $V_S = 0\text{ V}$		Room	8					pF
Drain Off Capacitance	$C_{D(off)}$		DG417 DG418	Room	8					
Channel On Capacitance	$C_{D(on)}$		DG417 DG418 DG419	Room	30 35					

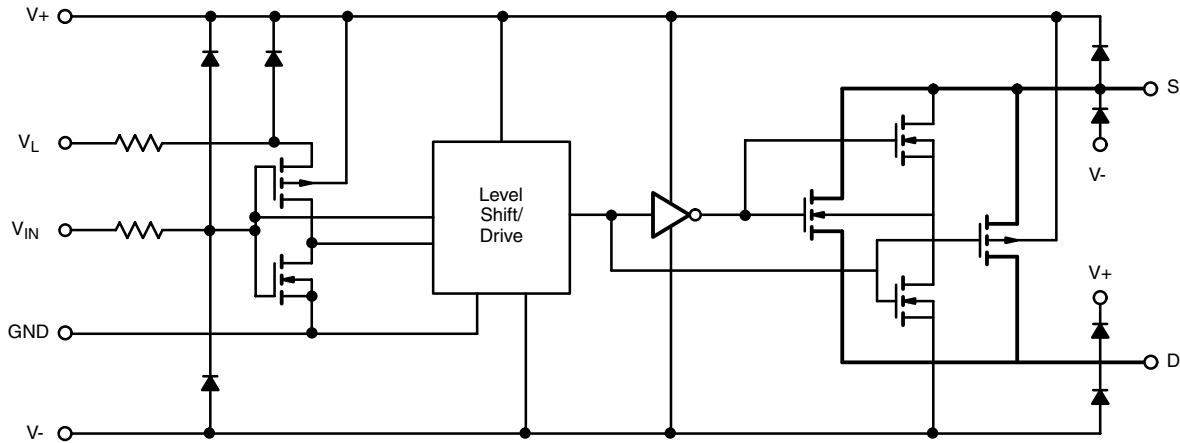

SPECIFICATIONS ^a									
Parameter	Symbol	Test Conditions Unless Otherwise Specified $V_+ = 15\text{ V}$, $V_- = -15\text{ V}$ $V_L = 5\text{ V}$, $V_{IN} = 2.4\text{ V}$, 0.8 V^f	Temp ^b	Typ ^c	A Suffix - 55 to 125 °C		D Suffix - 40 to 85 °C		Unit
					Min ^d	Max ^d	Min ^d	Max ^d	
Power Supplies									
Positive Supply Current	I ₊	$V_+ = 16.5\text{ V}$, $V_- = -16.5\text{ V}$ $V_{IN} = 0$ or 5 V	Room Full	0.001		1 5		1 5	μA
Negative Supply Current	I ₋		Room Full	- 0.001	- 1 - 5		- 1 - 5		
Logic Supply Current	I _L		Room Full	0.001		1 5		1 5	
Ground Current	I _{GND}		Room Full	- 0.0001	- 1 - 5		- 1 - 5		

SPECIFICATIONS FOR UNIPOLAR SUPPLIES ^a									
Parameter	Symbol	Test Conditions Unless Otherwise Specified $V_+ = 12\text{ V}$, $V_- = 0\text{ V}$ $V_L = 5\text{ V}$, $V_{IN} = 2.4\text{ V}$, 0.8 V^f	Temp ^b	Typ ^c	A Suffix - 55 to 125 °C		D Suffix - 40 to 85 °C		Unit
					Min ^d	Max ^d	Min ^d	Max ^d	
Analog Switch									
Analog Signal Range ^e	V _{ANALOG}		Full		0	12	0	12	V
Drain-Source On-Resistance	r _{DS(on)}	$I_S = -10\text{ mA}$, $V_D = 3.8\text{ V}$ $V_+ = 10.8\text{ V}$	Room	40					Ω
Dynamic Characteristics									
Turn-On Time	t _{ON}	R _L = 300 Ω, C _L = 35 pF, V _S = 8 V See Switching Time Test Circuit	Room	110					ns
Turn-Off Time	t _{OFF}		Room	40					
Break-Before-Make Time Delay	t _D	DG419 Only R _L = 300 Ω, C _L = 35 pF	Room	60					
Charge Injection	Q	C _L = 10 nF, V _{gen} = 0 V, R _{gen} = 0 Ω	Room	5					pC
Power Supplies									
Positive Supply Current	I ₊	$V_+ = 13.2\text{ V}$, $V_L = 5.25\text{ V}$ $V_{IN} = 0$ or 5 V	Room	0.001					μA
Negative Supply Current	I ₋		Room	- 0.001					
Logic Supply Current	I _L		Room	0.001					
Ground Current	I _{GND}		Room	- 0.001					

Notes:

- a. Refer to PROCESS OPTION FLOWCHART.
- b. Room = 25 °C, Full = as determined by the operating temperature suffix.
- c. Typical values are for DESIGN AID ONLY, not guaranteed nor subject to production testing.
- d. The algebraic convention whereby the most negative value is a minimum and the most positive a maximum, is used in this data sheet.
- e. Guaranteed by design, not subject to production test.
- f. V_{IN} = input voltage to perform proper function.

Stresses beyond those listed under "Absolute Maximum Ratings" may cause permanent damage to the device. These are stress ratings only, and functional operation of the device at these or any other conditions beyond those indicated in the operational sections of the specifications is not implied. Exposure to absolute maximum rating conditions for extended periods may affect device reliability.

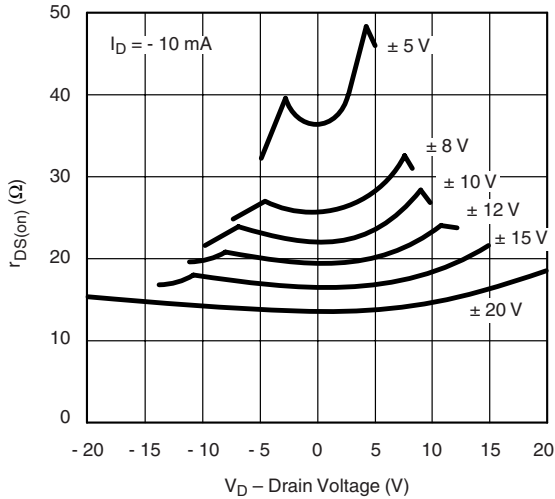
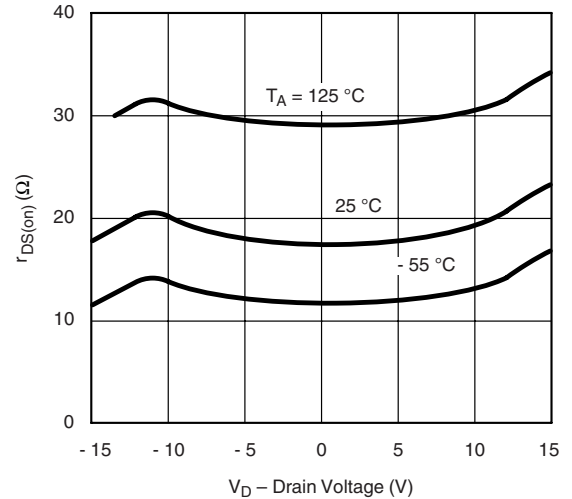
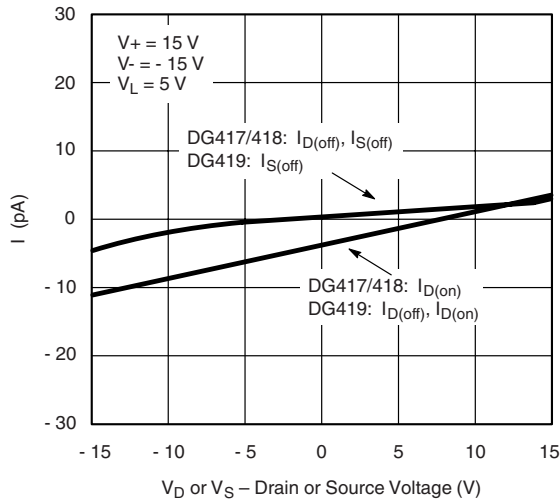
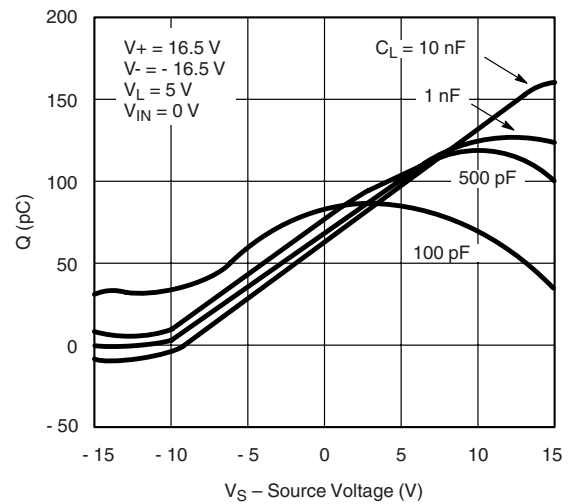
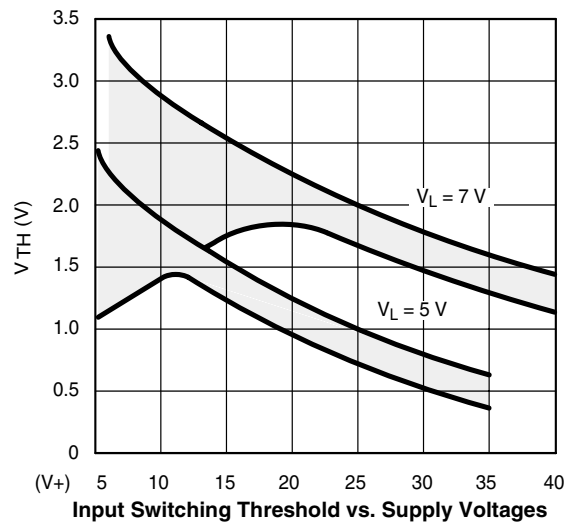
TYPICAL CHARACTERISTICS 25 °C, unless otherwise noted

 $r_{DS(on)}$ vs. V_D and Supply Voltage

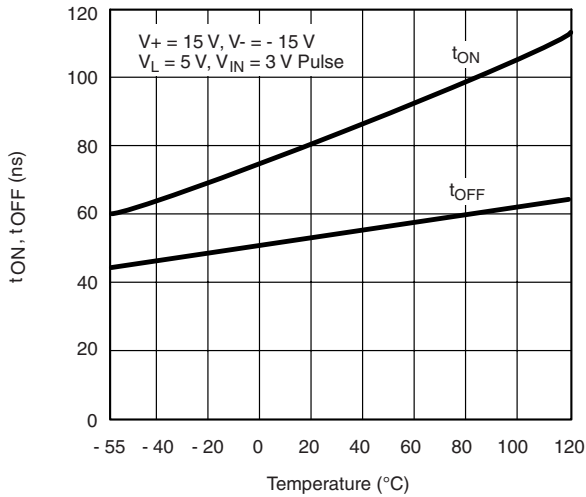
 $r_{DS(on)}$ vs. Temperature

Leakage Currents vs. Analog Voltage

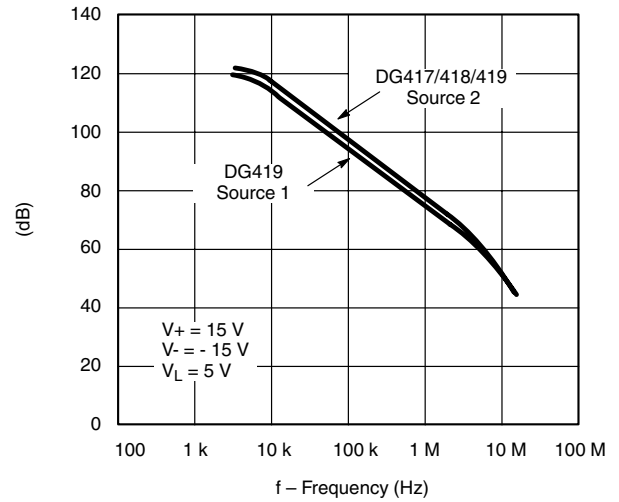
Drain Charge Injection

Input Switching Threshold vs. Supply Voltages

TYPICAL CHARACTERISTICS 25 °C, unless otherwise noted



Switching Time vs. Temperature



Crosstalk and Off Isolation vs. Frequency

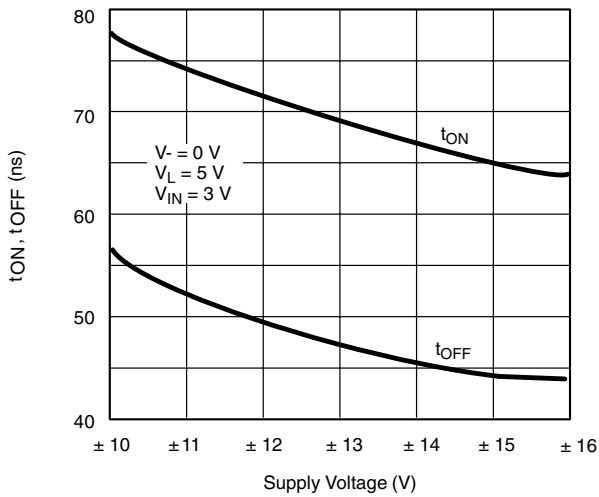

Switching Time vs. Supply Voltages

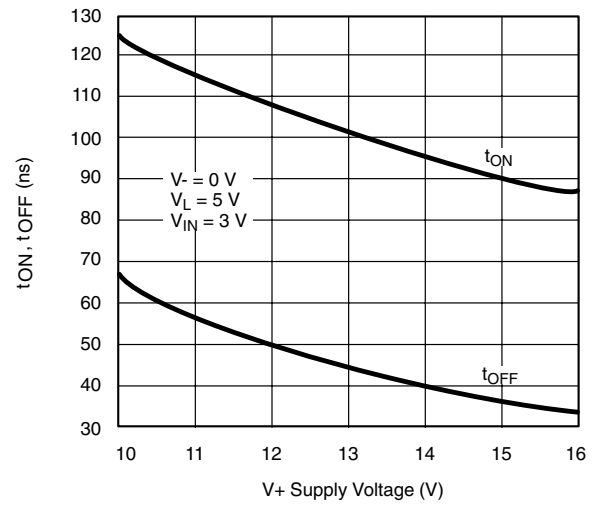

Switching Time vs. V_+

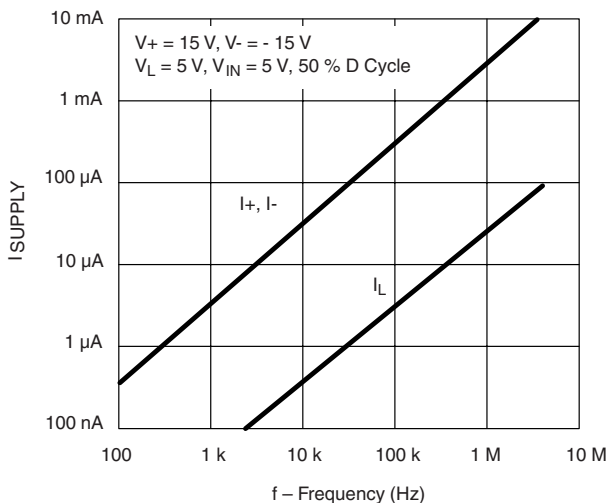

Power Supply Currents vs. Switching Frequency

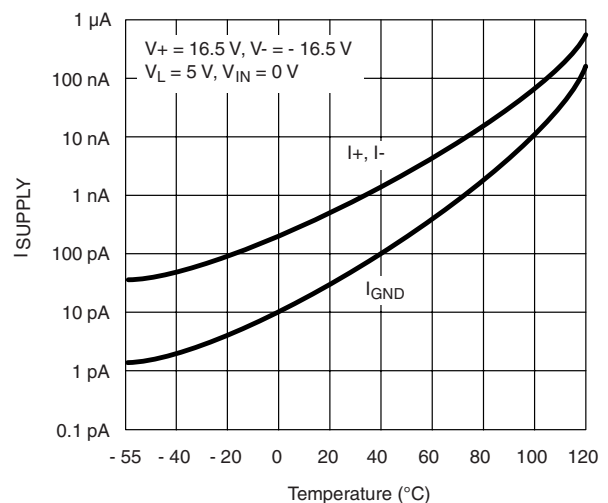

Supply Current vs. Temperature

TEST CIRCUITS

V_O is the steady state output with the switch on.

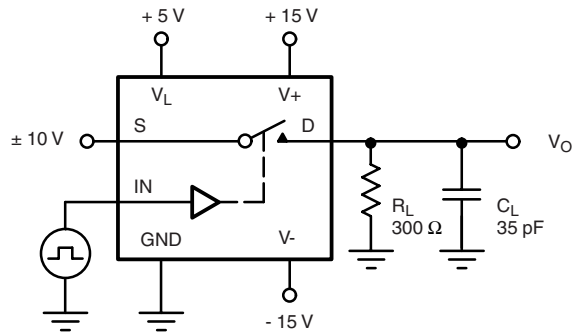

C_L (includes fixture and stray capacitance)

$$V_O = V_S \frac{R_L}{R_L + r_{DS(on)}}$$

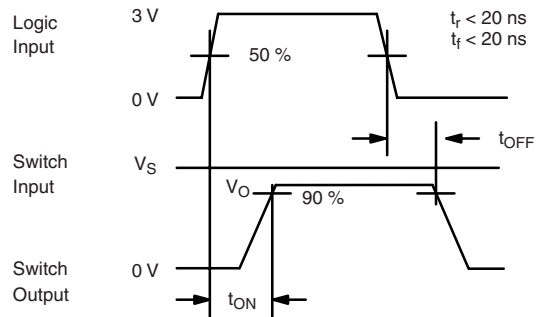

Note: Logic input waveform is inverted for switches that have the opposite logic sense.

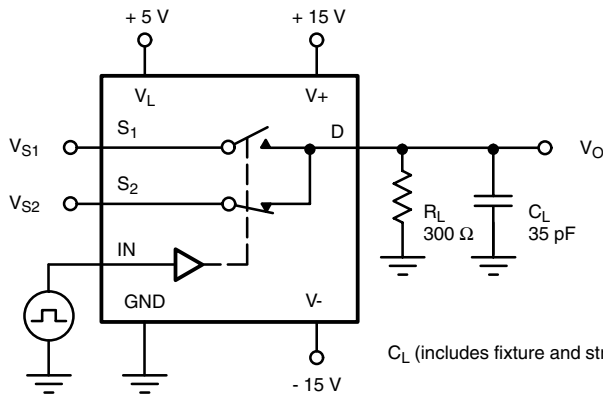
Figure 2. Switching Time (DG417/418)

C_L (includes fixture and stray capacitance)

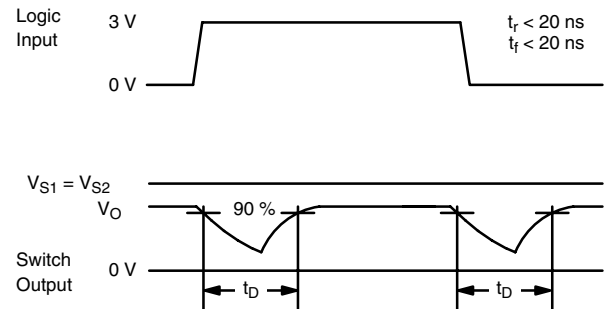
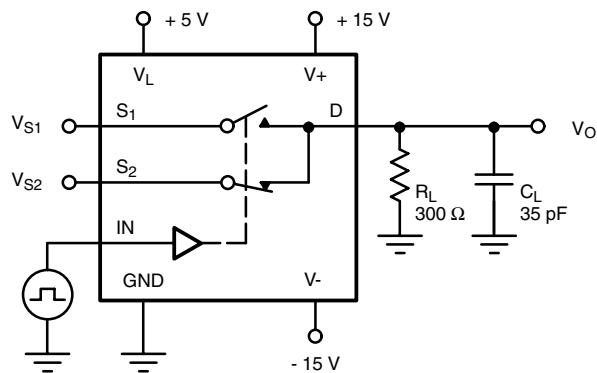
Figure 3. Break-Before-Make (DG419)

C_L (includes fixture and stray capacitance)

$$V_O = V_S \frac{R_L}{R_L + r_{DS(on)}}$$

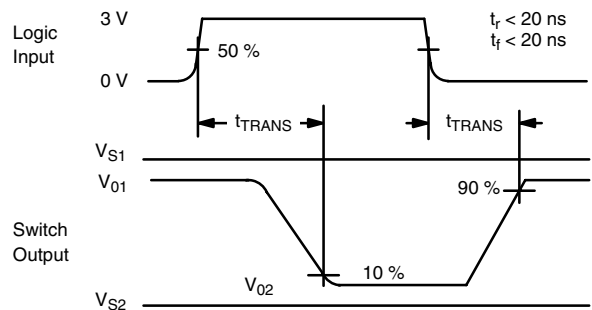
Figure 4. Transition Time (DG419)

TEST CIRCUITS

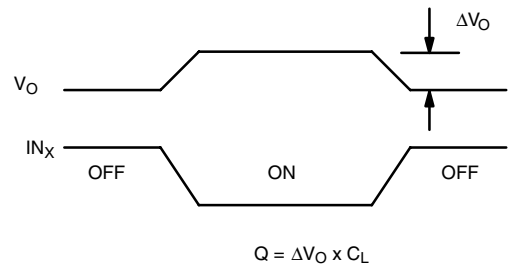
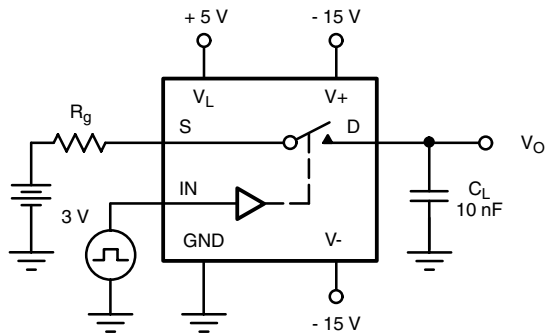
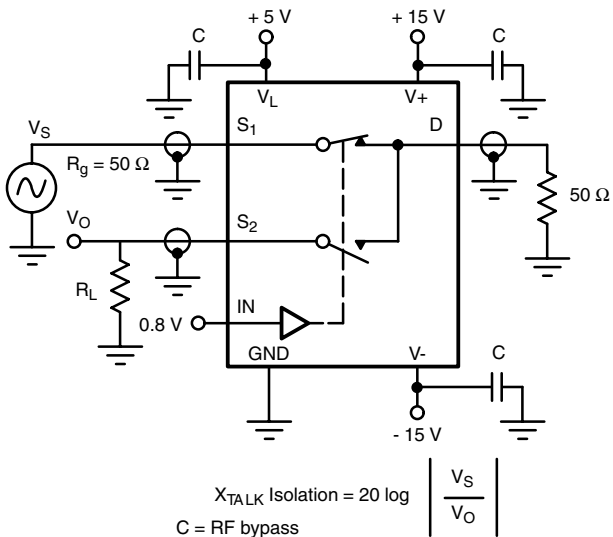

Figure 5. Charge Injection



$$X_{\text{TALK Isolation}} = 20 \log \left| \frac{V_S}{V_O} \right|$$

C = RF bypass

Figure 6. Crosstalk (DG419)

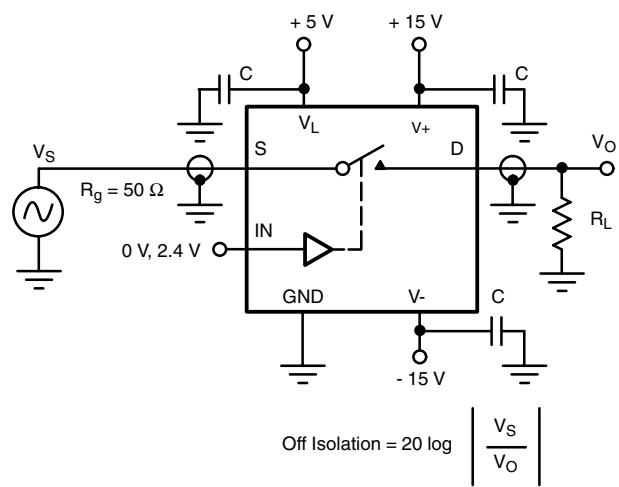

$$\text{Off Isolation} = 20 \log \left| \frac{V_S}{V_O} \right|$$

Figure 7. Off Isolation

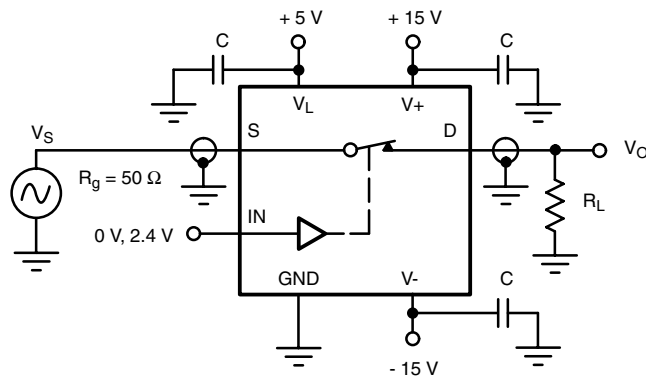
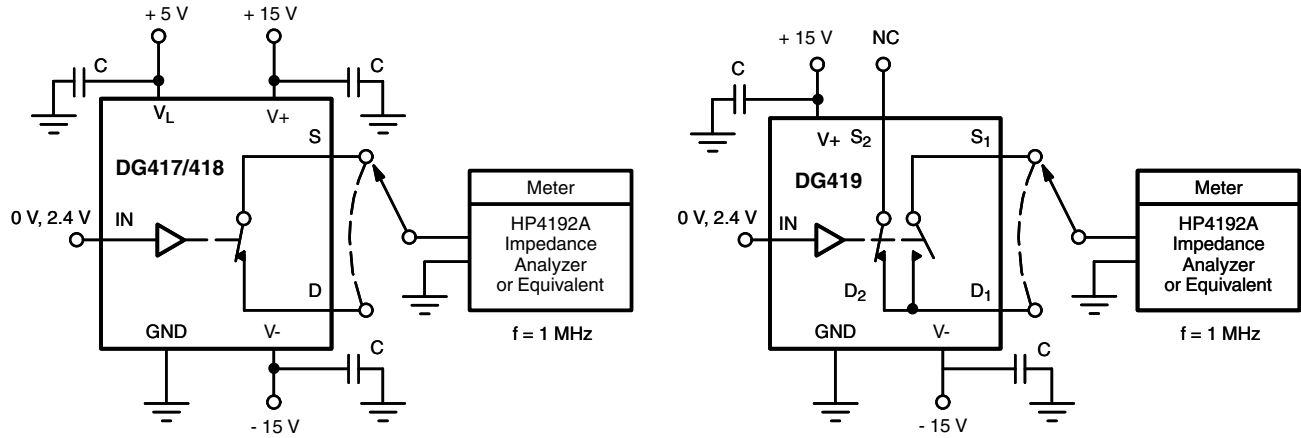

Figure 8. Insertion Loss

TEST CIRCUITS

Figure 9. Source/Drain Capacitances
APPLICATIONS
Switched Signal Powers Analog Switch

The analog switch in Figure 10 derives power from its input signal, provided the input signal amplitude exceeds 4 V and its frequency exceeds 1 kHz.

This circuit is useful when signals have to be routed to either of two remote loads. Only three conductors are required: one for the signal to be switched, one for the control signal and a common return.

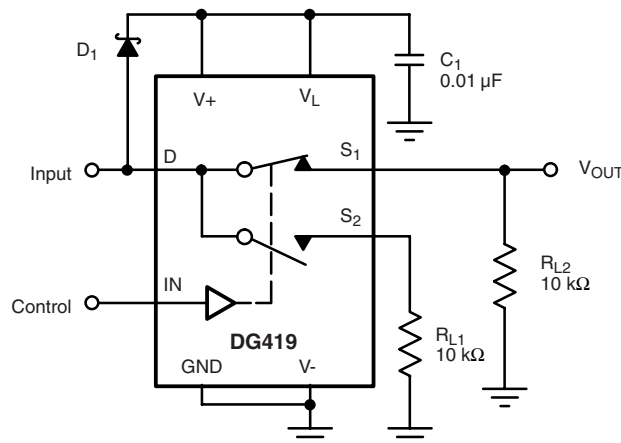
A positive input pulse turns on the clamping diode D_1 and charges C_1 . The charge stored on C_1 is used to power the chip; operation is satisfactory because the switch requires less than 1 μA of stand-by supply current. Loading of the signal source is imperceptible. The DG419's on-resistance is a low 100 Ω for a 5 V input signal.

Figure 10. Switched Signal Powers Remote SPDT Analog Switch

APPLICATIONS

Micropower UPS Transfer Switch

When V_{CC} drops to 3.3 V, the DG417 changes states, closing SW_1 and connecting the backup cell, as shown in Figure 10. D_1 prevents current from leaking back towards the rest of the circuit. Current consumption by the CMOS analog switch is around 100 pA; this ensures that most of the power available is applied to the memory, where it is really needed. In the stand-by mode, hundreds of A are sufficient to retain memory data.

When the 5 V supply comes back up, the resistor divider senses the presence of at least 3.5 V, and causes a new change of state in the analog switch, restoring normal operation.

Programmable Gain Amplifier

The DG419, as shown in Figure 11, allows accurate gain selection in a small package. Switching into virtual ground reduces distortion caused by $r_{DS(on)}$ variation as a function of analog signal amplitude.

GaAs FET Driver

The DG419, as shown in Figure 12 may be used as a GaAs FET driver. It translates a TTL control signal into - 8 V, 0 V level outputs to drive the gate.

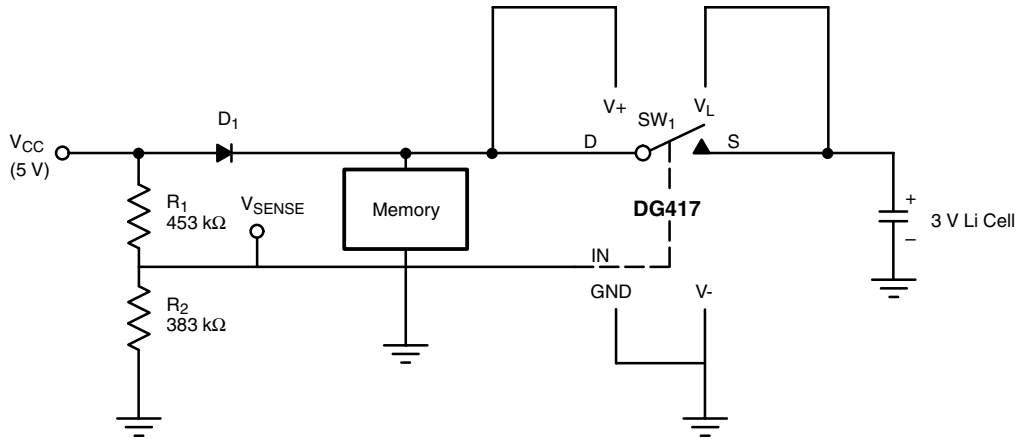

Figure 11. Micropower UPS Circuit

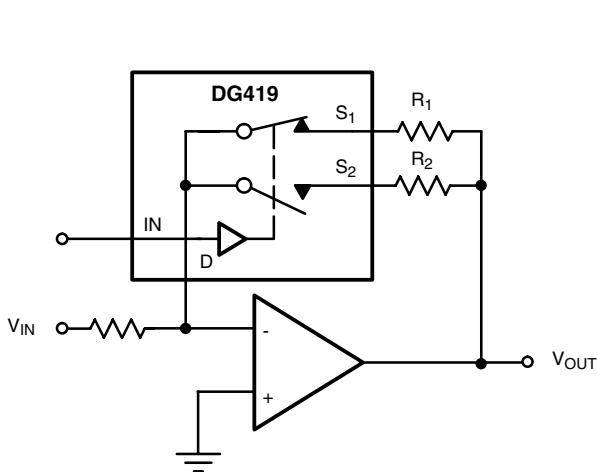

Figure 12. Programmable Gain Amplifier

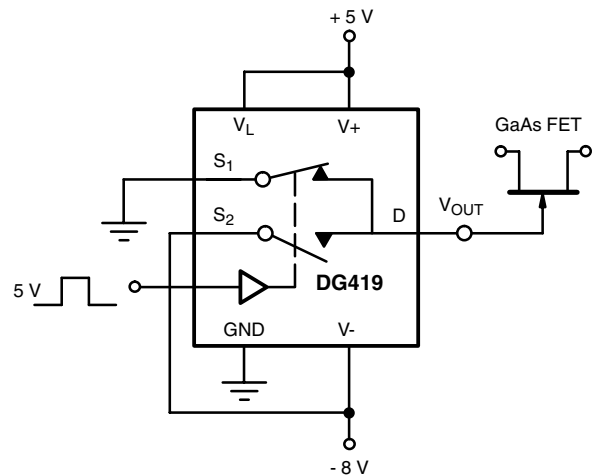

Figure 13. GaAs FET Driver

Vishay Siliconix maintains worldwide manufacturing capability. Products may be manufactured at one of several qualified locations. Reliability data for Silicon Technology and Package Reliability represent a composite of all qualified locations. For related documents such as package/tape drawings, part marking, and reliability data, see <http://www.vishay.com/ppg?70051>.



Notice

Specifications of the products displayed herein are subject to change without notice. Vishay Intertechnology, Inc., or anyone on its behalf, assumes no responsibility or liability for any errors or inaccuracies.

Information contained herein is intended to provide a product description only. No license, express or implied, by estoppel or otherwise, to any intellectual property rights is granted by this document. Except as provided in Vishay's terms and conditions of sale for such products, Vishay assumes no liability whatsoever, and disclaims any express or implied warranty, relating to sale and/or use of Vishay products including liability or warranties relating to fitness for a particular purpose, merchantability, or infringement of any patent, copyright, or other intellectual property right.

The products shown herein are not designed for use in medical, life-saving, or life-sustaining applications. Customers using or selling these products for use in such applications do so at their own risk and agree to fully indemnify Vishay for any damages resulting from such improper use or sale.