

Precision 8-Channel/Dual 4-Channel CMOS Analog Multiplexers

DESCRIPTION

The DG508B is an 8-channel single-ended analog multiplexer designed to connect one of eight inputs to a common output as determined by a 3-bit binary address (A0, A1, A2). The DG509B is a dual 4-channel differential analog multiplexer designed to connect one of four differential inputs to a common dual output as determined by its 2-bit binary address (A0, A1). Break-before-make switching action protects against momentary crosstalk between adjacent channels.

An on channel conducts current equally well in both directions. In the off state each channel blocks voltages up to the power supply rails. An enable (EN) function allows the user to reset the multiplexer/demultiplexer to all switches off for stacking several devices. All control inputs, addresses (Ax) and enable (EN) are TTL compatible over the full specified operating temperature range.

The DG508B and DG509B are fabricated on an enhanced SG-II CMOS process that achieves improved performance on: reduced charge injection, lower device leakage, and minimized parasitic capacitance.

As the DG508, DG509 has a long history in the industry with many suppliers offering copies - and in some cases improved variations - with the best in class improvements, the Vishay Siliconix new version of the DG508B, DG509B are the superior alternatives to what is currently available.

Applications for the DG508B, DG509B include high speed and high precision data acquisition, audio signal switching and routing, ATE systems, and avionics. High performance and low power dissipation make them ideal for battery operated and remote instrumentation applications.

The DG508B and DG509B have the absolute maximum voltage rating extended to 44 V. Additionally, single supply operation is also allowed. An epitaxial layer prevents latch-up.

The DG508B and DG509B are both available in 16-lead SOIC, TSSOP, PDIP, and miniQFN (1.8 mm x 2.6 mm) package options with extended temperature range of - 40 °C to + 125 °C.

For more information, refer to Vishay Siliconix DG508B, DG509B evaluation board note.

FEATURES

- Operate with single or dual power supply
- V+ to V- analog signal swing range
- 44 V power supply maximum rating
- Extended operate temperature range: - 40 °C to + 125 °C
- Low leakage typically < 3 pA
- Low charge injection - $Q_{INJ} = 2$ pC
- Low power - $I_{SUPPLY} = 10$ μ A
- TTL compatible logic
- > 250 mA latch up current per JESD78
- Available in SOIC16, TSSOP16, PDIP, and miniQFN16 packages
- Superior alternative to:
 - ADG508A, DG508A, HI-508
 - ADG509A, DG509A, HI-509
- **Compliant to RoHS Directive 2002/95/EC**
- **Halogen-free according to IEC 61249-2-21 definition**



RoHS
COMPLIANT
HALOGEN
FREE

BENEFITS

- Reduced switching errors
- Reduced glitching
- Improved data throughput
- Reduced power consumption
- Increased ruggedness
- Wide supply ranges (± 5 V to ± 20 V)

APPLICATIONS

- Data acquisition systems
- Audio and video signal routing
- ATE systems
- Medical instrumentation

FUNCTIONAL BLOCK DIAGRAM AND PIN CONFIGURATION

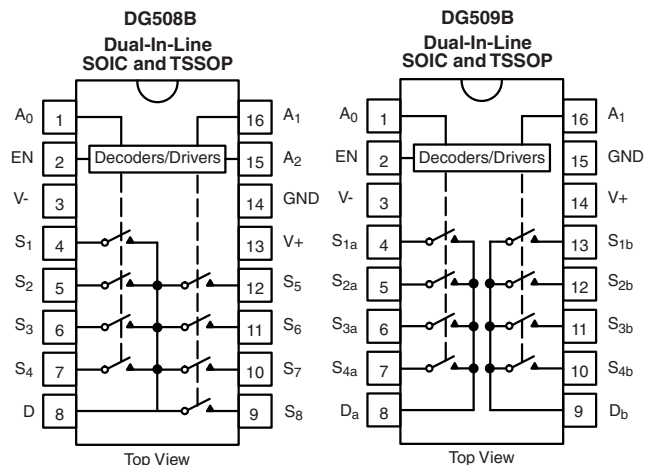

FUNCTIONAL BLOCK DIAGRAM AND PIN CONFIGURATION

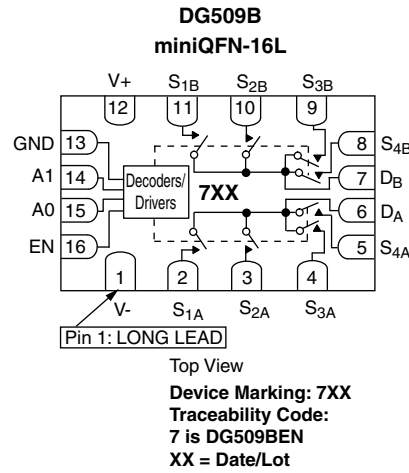
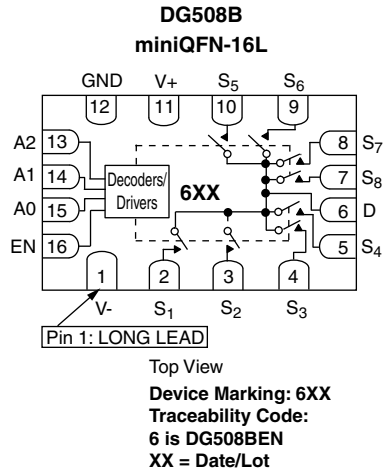

TRUTH TABLES AND ORDERING INFORMATION

TRUTH TABLE (DG508B)				
A ₂	A ₁	A ₀	EN	On Switch
X	X	X	0	None
0	0	0	1	1
0	0	1	1	2
0	1	0	1	3
0	1	1	1	4
1	0	0	1	5
1	0	1	1	6
1	1	0	1	7
1	1	1	1	8

TRUTH TABLE (DG509B)			
A ₁	A ₀	EN	On Switch
X	X	0	None
0	0	1	1
0	1	1	2
1	0	1	3
1	1	1	4

Logic "0" = $V_{IL} \leq 0.8\text{ V}$
 Logic "1" = $V_{IH} \geq 2.0\text{ V}$
 X = Do not care

ORDERING INFORMATION (DG508B)		
Temp. Range	Package	Part Number
- 40 °C to 125 °C ^a	16-Pin SOIC	DG508BEY-T1-E3
	16-Pin TSSOP	DG508BEQ-T1-E3
	16-Pin PDIP	DG508BEJ-E3
	16-Pin MiniQFN	DG508BEN-T1-GE4

ORDERING INFORMATION (DG509B)		
Temp. Range	Package	Part Number
- 40 °C to 125 °C ^a	16-Pin SOIC	DG509BEY-T1-E3
	16-Pin TSSOP	DG509BEQ-T1-E3
	16-Pin PDIP	DG509BEJ-E3
	16-Pin MiniQFN	DG509BEN-T1-GE4

Notes:

a. - 40 °C to 85 °C datasheet limits apply.



ABSOLUTE MAXIMUM RATINGS			
Parameter		Limit	Unit
Voltages Referenced to V-	V+	44	V
	GND	25	
Digital Inputs ^a , V _S , V _D		(V-) - 2 to (V+) + 2 or 20 mA, whichever occurs first	
Current (Any terminal)		30	mA
Peak Current, S or D (Pulsed at 1 ms, 10 % duty cycle max.)		100	
Storage Temperature	(EY, EQ, EJ, EN suffix)	- 65 to 150	°C
Power Dissipation (Packages) ^b	16-Pin Narrow SOIC ^c	600	mW
	16-Pin TSSOP ^d	450	
	16-Pin PDIP ^e	510	
	16-Pin miniQFN ^f	525	
Thermal Resistance (θ _{J-A}) ^b	16-Pin Narrow SOIC ^c	125	°C/W
	16-Pin TSSOP ^d	178	
	16-Pin PDIP ^e	159.6	
	16-Pin miniQFN ^f	152	

Notes:

- a. Signals on S_X, D_X or IN_X exceeding V+ or V- will be clamped by internal diodes. Limit forward diode current to maximum current ratings.
- b. All leads soldered or welded to PC board.
- c. Derate 8.0 mW/°C above 70 °C.
- d. Derate 5.6 mW/°C above 70 °C.
- e. Derate 6.3 mW/°C above 70 °C.
- f. Derate 6.6 mW/°C above 70 °C.

SPECIFICATIONS										
Parameter	Symbol	Test Conditions Unless Otherwise Specified V+ = 15 V, V- = - 15 V (± 10 %) V _{AX} , V _{EN} = 2.0 V, 0.8 V ^a	Temp. ^b	Typ. ^c	- 40 °C to 125 °C		- 40 °C to 85 °C		Unit	
					Min. ^d	Max. ^d	Min. ^d	Max. ^d		
Analog Switch										
Analog Signal Range ^e	V _{ANALOG}		Full		- 15	15	- 15	15	V	
Drain-Source On-Resistance	R _{DS(on)}	V _D = ± 10 V, I _S = - 1 mA	Room	180		380		380	Ω	
			Full			480		450		
R _{DS(on)} Matching	ΔR _{DS(on)}	V _D = ± 10 V	Room	10						
Source Off Leakage Current	I _{S(off)}	V _D = ± 10 V V _S = ∓ 10 V V _{EN} = 0 V	Room		- 1	1	- 1	1	nA	
Drain Off Leakage Current	I _{D(off)}		DG508B	Room		- 1	1	- 1		1
			DG508B	Full		- 100	100	- 100		100
			DG509B	Room		- 1	1	- 1		1
			DG509B	Full		- 50	50	- 50		50
Drain On Leakage Current	I _{D(on)}		DG508B	Room		- 1	1	- 1		1
		DG508B	Full		- 100	100	- 100	100		
		DG509B	Room		- 1	1	- 1	1		
		DG509B	Full		- 50	50	- 50	50		
Digital Control										
Logic High Input Voltage	V _{INH}		Full		2.0		2.0		V	
Logic Low Input Voltage	V _{INL}		Full			0.8		0.8		
Logic High Input Current	I _{IH}	V _{AX} , V _{EN} = 2.0 V	Full		- 1	1	- 1	1	μA	
Logic Low Input Current	I _{IL}	V _{AX} , V _{EN} = 0.8 V	Full		- 1	1	- 1	1		
Logic Input Capacitance ^e	C _{in}	f = 1 MHz	Room	4					pF	

SPECIFICATIONS										
Parameter	Symbol	Test Conditions Unless Otherwise Specified $V_+ = 15\text{ V}$, $V_- = -15\text{ V}$ ($\pm 10\%$) V_{AX} , $V_{EN} = 2.0\text{ V}$, 0.8 V^a	Temp. ^b	Typ. ^c	- 40 °C to 125 °C		- 40 °C to 85 °C		Unit	
					Min. ^d	Max. ^d	Min. ^d	Max. ^d		
Dynamic Characteristics										
Transition Time	t_{TRANS}	$VS_1 = +10\text{ V}/-10\text{ V}$, $VS_8 = -10\text{ V}/+10\text{ V}$, $R_L = 1\text{ M}\Omega$, $C_L = 35\text{ pF}$	Room	145		300		300	ns	
			Full			400		400		
Break-Before-Make Interval	t_{OPEN}	$VS_1 = VS_8 = 5.0\text{ V}$, $C_L = 35\text{ pF}$, $R_L = 1\text{ k}\Omega$	Room	37	15		15			
			Full		1		1			
Enable Turn-On Time	$t_{ON(EN)}$	$VS_1 = 5\text{ V}$, VS_2 to $VS_8 = 0\text{ V}$, $R_L = 1\text{ k}\Omega$, $C_L = 35\text{ pF}$	Room	100		250		250		
Enable Turn-Off Time	$t_{OFF(EN)}$		Full			340		340		
			Room	90		240		240		
			Full			300		300		
Charge Injection ^e	Q_{INJ}	$C_L = 1\text{ nF}$, $R_{GEN} = 0\ \Omega$, $V_{GEN} = 0\text{ V}$	Full	2				pC		
Off Isolation ^e	OIRR	$C_L = 5\text{ pF}$, $R_L = 50\ \Omega$, $f = 1\text{ MHz}$	Room	- 81					dB	
Crosstalk ^e	XTALK		Room	- 88						
- 3 dB Bandwidth ^e	BW		$R_L = 50\ \Omega$	Room	250					MHz
Total Harmonic Distortion ^e	THD	$R_L = 10\text{ k}\Omega$, 5 V_{rms} $f = 20\text{ Hz}$ to 20 kHz	Room	0.04					%	
Source Off Capacitance ^e	$C_{S(off)}$	$f = 1\text{ MHz}$	Room	3					pF	
Drain Off Capacitance ^e	$C_{D(off)}$		DG508B	Room	13					
			DG509B	Room	8					
Drain On Capacitance ^e	$C_{D(on)}$		DG508B	Room	18					
		DG509B	Room	11						
Power Supply										
Positive Supply Current	I_+	V_{AX} , $V_{EN} = 0\text{ V}$ or V_+	Room	0.01		0.5		0.5	mA	
			Full			0.6		0.6		
Negative Supply Current	I_-		Full			- 200		- 200	μA	

SPECIFICATIONS (Single Supply 12 V)									
Parameter	Symbol	Test Conditions Unless Otherwise Specified $V_+ = 12\text{ V}$, $V_- = 0\text{ V}$ ($\pm 10\%$) V_{AX} , $V_{EN} = 2.0\text{ V}$, 0.8 V^a	Temp. ^b	Typ. ^c	- 40 °C to 125 °C		- 40 °C to 85 °C		Unit
					Min. ^d	Max. ^d	Min. ^d	Max. ^d	
Analog Switch									
Analog Signal Range ^e	V_{ANALOG}		Full		0	12	0	12	V
On-Resistance	$R_{DS(on)}$	$V_D = 10\text{ V}/0\text{ V}$, $I_S = 1\text{ mA}$	Room	265		500		500	Ω
			Full			650		600	
$R_{DS(on)}$ Matching	$\Delta R_{DS(on)}$		Room	10					
Switch Off Leakage Current	$I_{S(off)}$	$V_+ = 12\text{ V}$, $V_- = 0\text{ V}$ $V_D = 0\text{ V}/10\text{ V}$, $V_S = 10\text{ V}/0\text{ V}$	Room		- 1	1	- 1	1	nA
			Full		- 50	- 50	- 50	50	
	DG508B		Room		- 1	1	- 1	1	
			Full		- 100	100	- 100	100	
	DG509B		Room		- 1	1	- 1	1	
			Full		- 50	50	- 50	50	



SPECIFICATIONS (Single Supply 12 V)										
Parameter	Symbol	Test Conditions Unless Otherwise Specified $V_+ = 12\text{ V}$, $V_- = 0\text{ V}$ ($\pm 10\%$) V_{AX} , $V_{EN} = 2.0\text{ V}$, 0.8 V^a	Temp. ^b	Typ. ^c	- 40 °C to 125 °C		- 40 °C to 85 °C		Unit	
					Min. ^d	Max. ^d	Min. ^d	Max. ^d		
Analog Switch										
Channel On Leakage Current	$I_{D(on)}$	$V_+ = 12\text{ V}$, $V_- = 0\text{ V}$ $V_S = V_D = 0\text{ V}/10\text{ V}$	DG508B	Room		- 1	1	- 1	1	nA
				Full		- 100	100	- 100	100	
			DG509B	Room		- 1	1	- 1	1	
				Full		- 50	50	- 50	50	
Digital Control										
Logic High Input Voltage	V_{INH}		Full		2.0		2.0		V	
Logic Low Input Voltage	V_{INL}		Full			0.8		0.8		
Logic High Input Current	I_{IH}	V_{AX} , $V_{EN} = 2.0\text{ V}$	Full		- 1	1	- 1	1	μA	
Logic Low Input Current	I_{IL}	V_{AX} , $V_{EN} = 0.8\text{ V}$	Full		- 1	1	- 1	1		
Logic Input Capacitance ^e	C_{in}	$f = 1\text{ MHz}$	Room	4					pF	
Dynamic Characteristics										
Transition Time	t_{TRANS}	$V_{S1} = 10\text{ V}/0\text{ V}$, $V_{S8} = 0\text{ V}/10\text{ V}$, $R_L = 1\text{ M}\Omega$, $C_L = 35\text{ pF}$	Room	165		400		400	ns	
			Full			550		500		
Break-Before-Make Interval	t_{OPEN}	$V_{S1} = V_{S8} = 5\text{ V}$, $C_L = 35\text{ pF}$, $R_L = 1\text{ k}\Omega$	Room	37	15		15			
			Full		1		1			
Enable Turn-On Time	$t_{ON(EN)}$	$V_{S1} = 5\text{ V}$, V_{S2} to $V_{S8} = 0\text{ V}$, $R_L = 1\text{ k}\Omega$, $C_L = 35\text{ pF}$	Room	125		300		300		
			Full			550		425		
Enable Turn-Off Time	$t_{OFF(EN)}$		Room	75		250		250		
			Full			350		300		
Charge Injection ^e	Q_{INJ}	$C_L = 1\text{ nF}$, $R_{GEN} = 0\ \Omega$, $V_{GEN} = 0\text{ V}$	Full	2.5				pC		
Off Isolation ^e	OIRR	$C_L = 5\text{ pF}$, $R_L = 50\ \Omega$ $f = 1\text{ MHz}$	Room	- 80				dB		
Crosstalk ^e	X_{TALK}		Room	- 88						
- 3 dB Bandwidth ^e	BW	$R_L = 50\ \Omega$	Room	200				MHz		
Total Harmonic Distortion ^e	THD	$R_L = 10\text{ k}\Omega$, 5 V_{RMS} , $f = 20\text{ Hz}$ to 20 kHz	Room	0.26				%		
Source Off Capacitance ^e	$C_{S(off)}$	$f = 1\text{ MHz}$	Room		2			pF		
Drain Off Capacitance ^e	$C_{D(off)}$			DG508B	13					
				DG509B	8					
Channel On Capacitance ^e	$C_{D(on)}$			DG508B	17					
		DG509B	12							
Power Supply										
Power Supply Current	I_+	V_{AX} , $V_{EN} = 0\text{ V}$, or V_+	Room	0.01		0.5		0.5	mA	
			Full			0.6		0.6		

Notes:

- a. V_{AX} , V_{EN} = input voltage perform proper function.
- b. Room = 25 °C, Full = as determined by the operating temperature suffix.
- c. Typical values are for DESIGN AID ONLY, not guaranteed nor subject to production testing.
- d. The algebraic convention whereby the most negative value is a minimum and the most positive a maximum, is used in this datasheet.
- e. Guaranteed by design, not subject to production test.
- f. $\Delta R_{DS(on)} = R_{DS(on)} \text{ max.} - R_{DS(on)} \text{ min.}$

Stresses beyond those listed under "Absolute Maximum Ratings" may cause permanent damage to the device. These are stress ratings only, and functional operation of the device at these or any other conditions beyond those indicated in the operational sections of the specifications is not implied. Exposure to absolute maximum rating conditions for extended periods may affect device reliability.

SCHEMATIC DIAGRAM (Typical Channel)

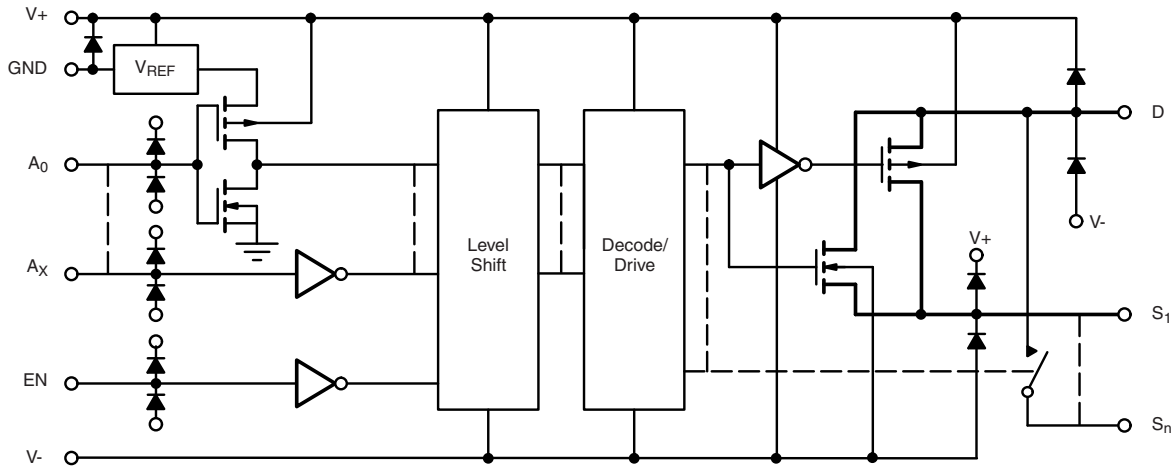
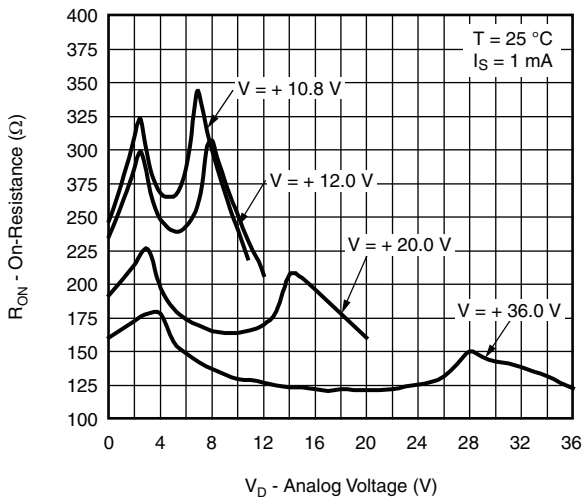
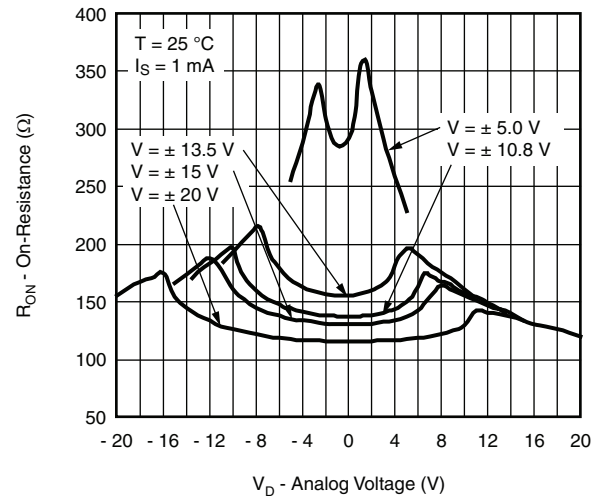

Figure 1.

TYPICAL CHARACTERISTICS (25 °C, unless otherwise noted)



On-Resistance vs. V_D and Single Supply Voltage



On-Resistance vs. V_D and Dual Supply Voltage

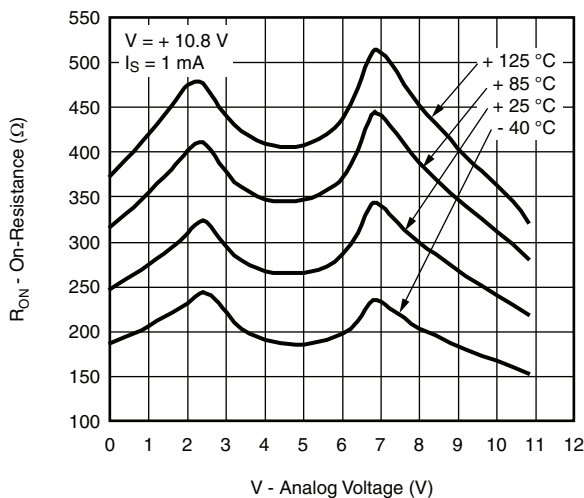

On-Resistance vs. Analog Voltage and Temperature

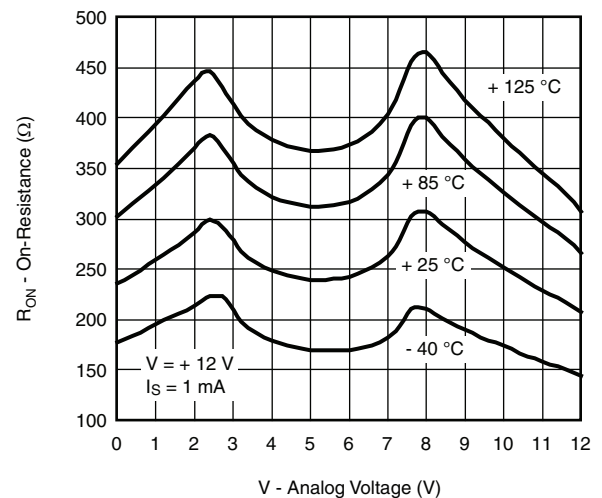

On-Resistance vs. Analog Voltage and Temperature

TYPICAL CHARACTERISTICS (25 °C, unless otherwise noted)

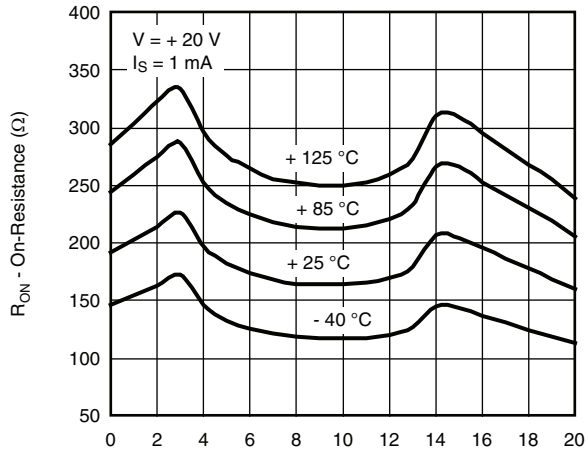

V - Analog Voltage (V)
On-Resistance vs. Analog Voltage and Temperature

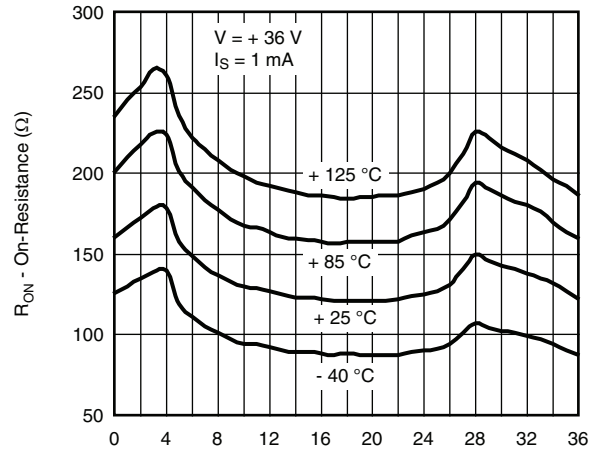

V - Analog Voltage (V)
On-Resistance vs. Analog Voltage and Temperature

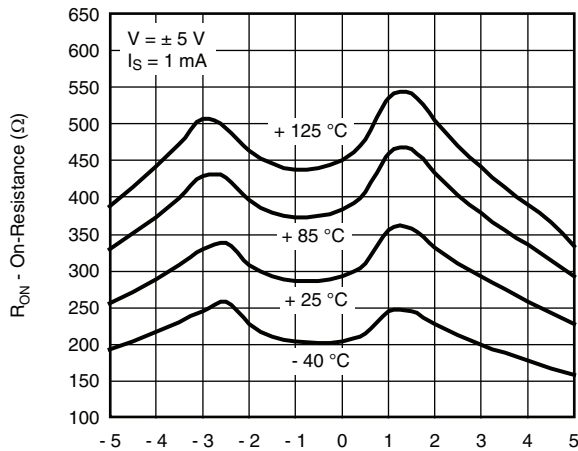

V - Analog Voltage (V)
On-Resistance vs. Analog Voltage and Temperature

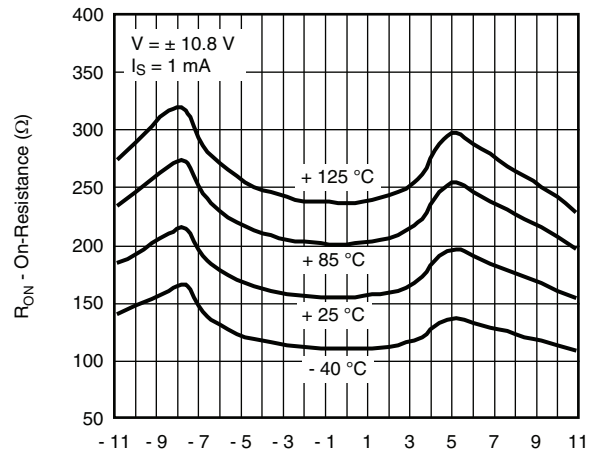

V - Analog Voltage (V)
On-Resistance vs. Analog Voltage and Temperature

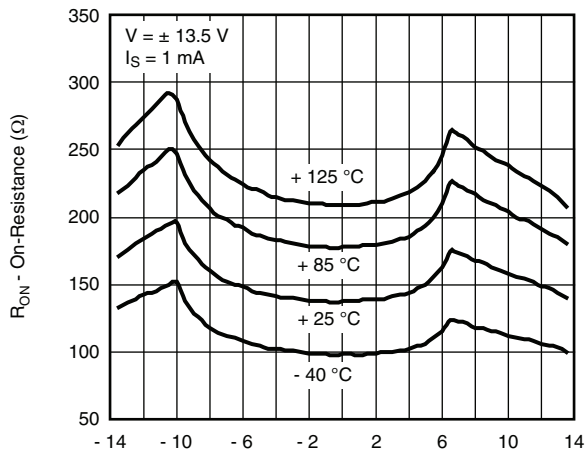

V - Analog Voltage (V)
On-Resistance vs. Analog Voltage and Temperature

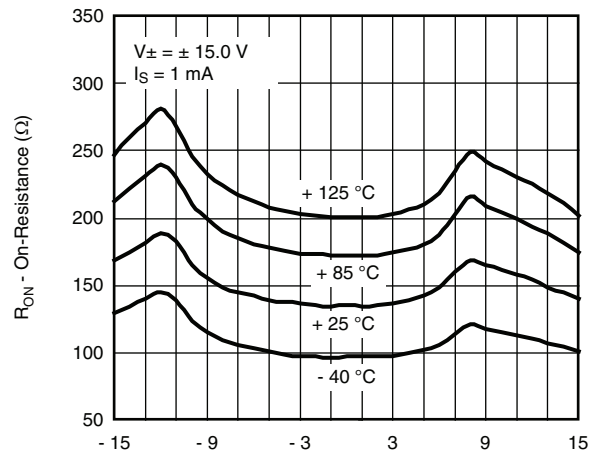

V - Analog Voltage (V)
On-Resistance vs. Analog Voltage and Temperature

TYPICAL CHARACTERISTICS (25 °C, unless otherwise noted)

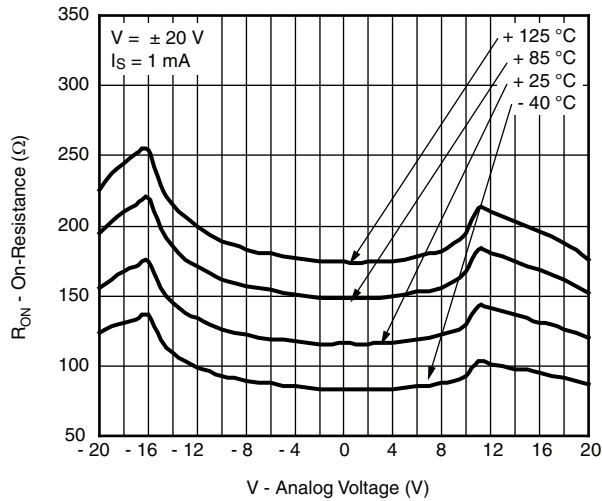

On-Resistance vs. Analog Voltage and Temperature

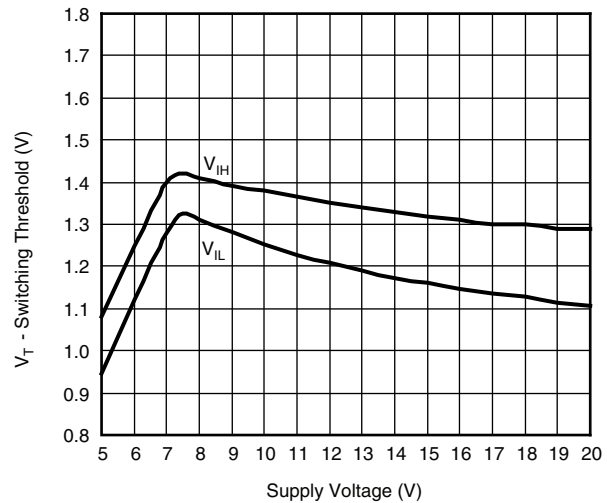

Switching Threshold vs. Supply Voltage

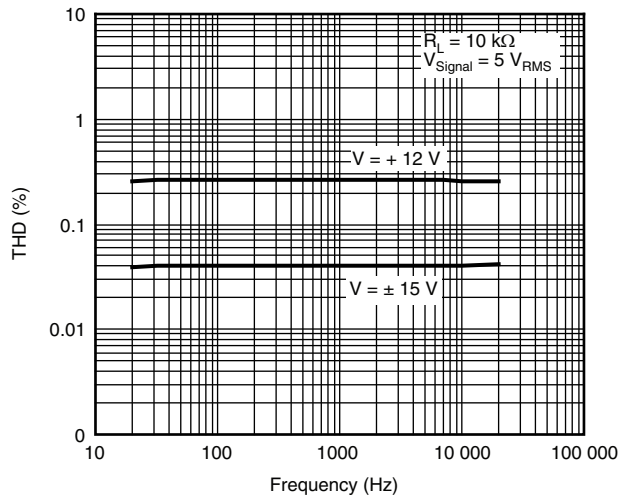

THD vs. Frequency

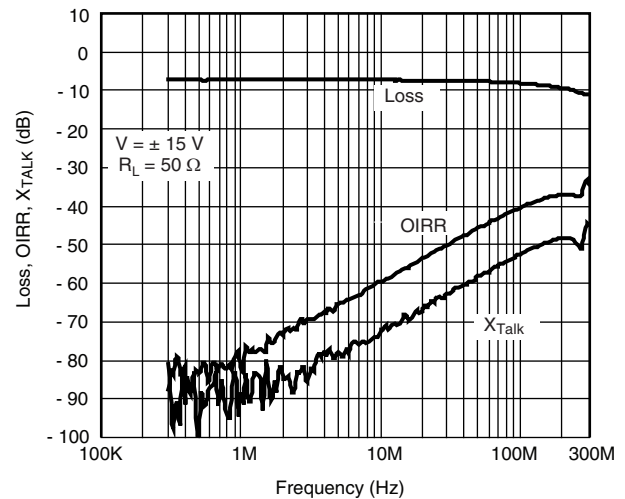

Insertion Loss, Off-Isolation, Crosstalk vs. Frequency

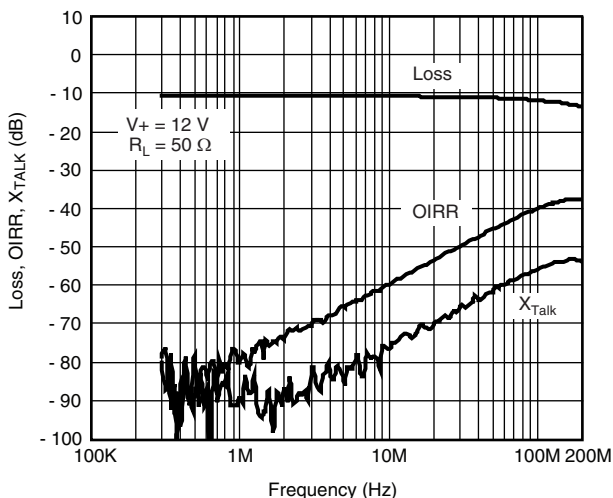

Insertion Loss, Off-Isolation, Crosstalk vs. Frequency

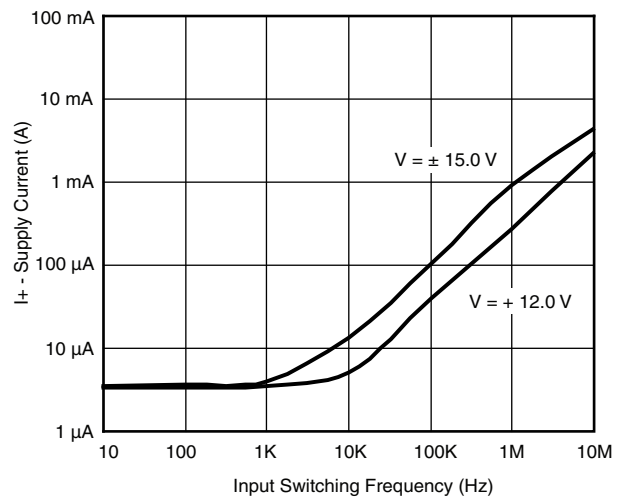

Supply Current vs. Input Switching Frequency

TYPICAL CHARACTERISTICS (25 °C, unless otherwise noted)

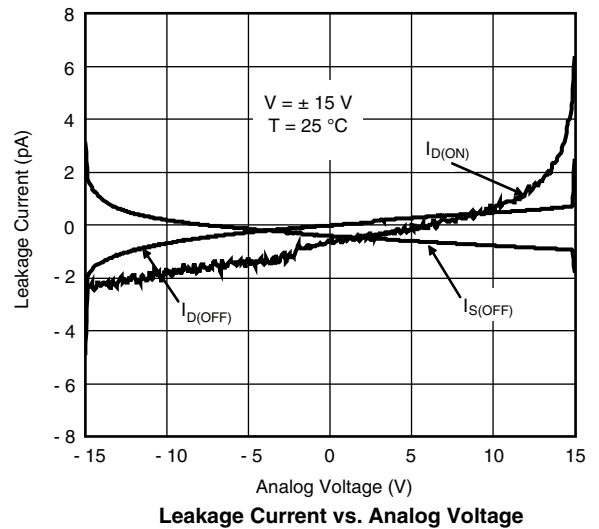
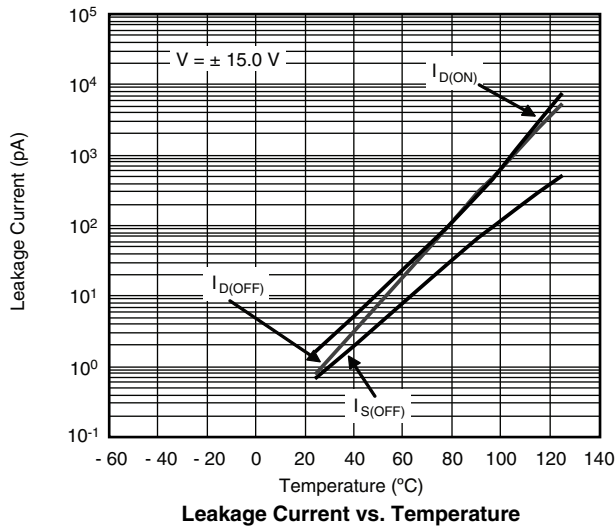
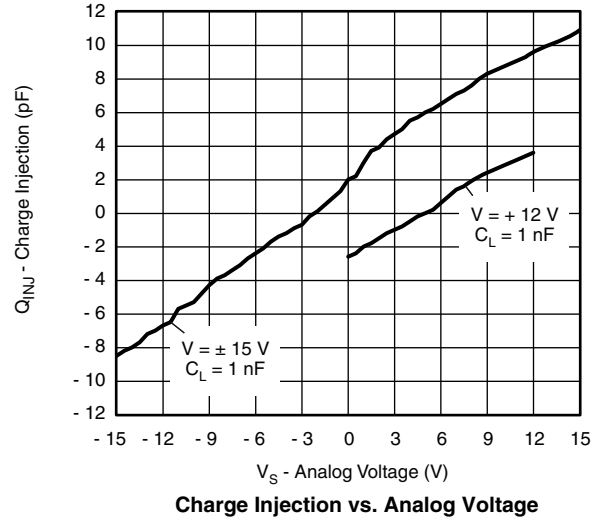
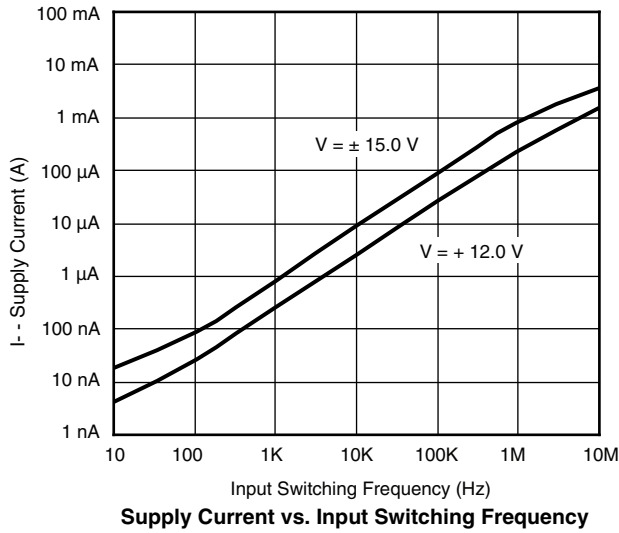

TEST CIRCUITS

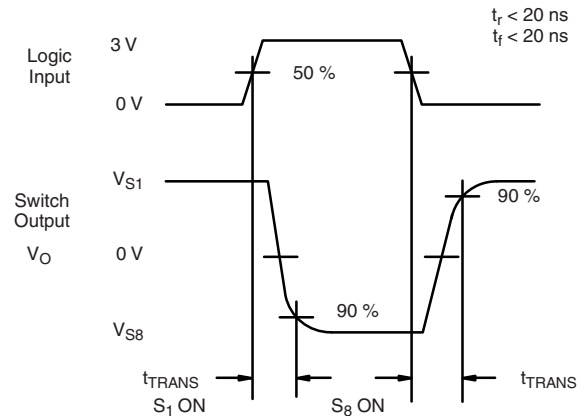
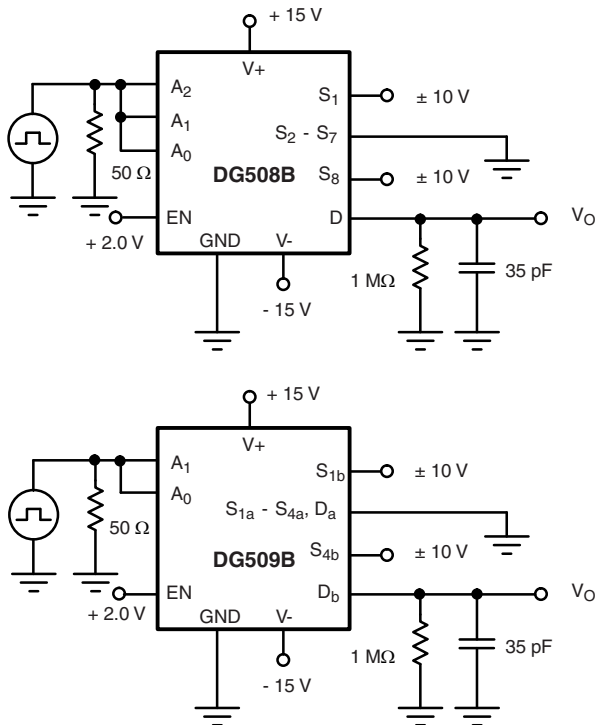

Figure 2. Transition Time

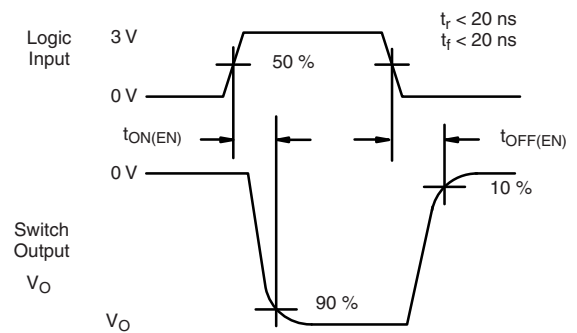
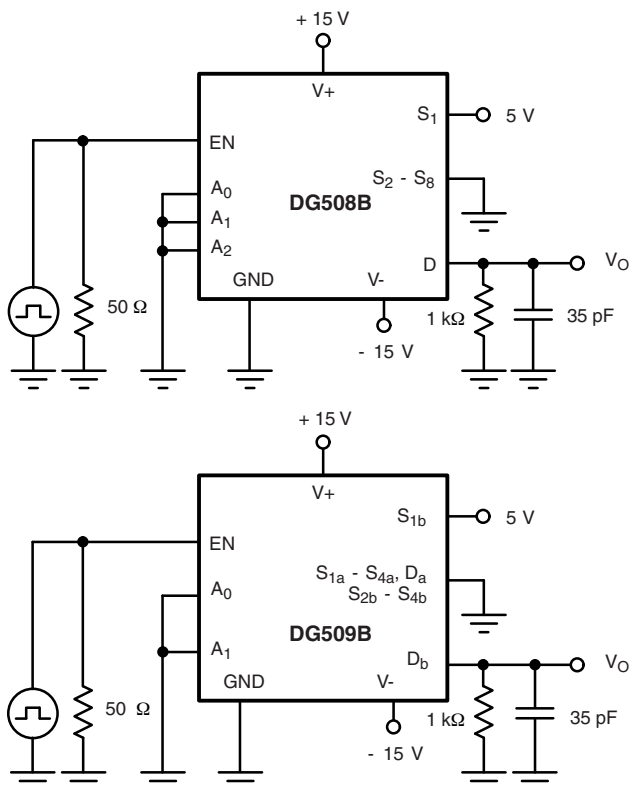
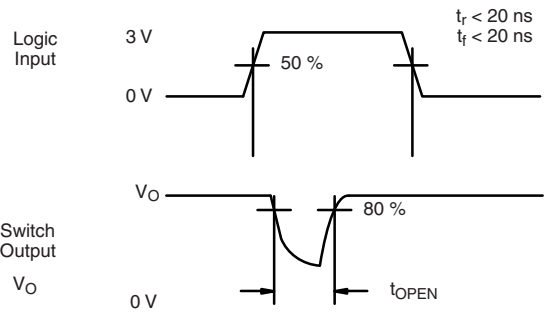
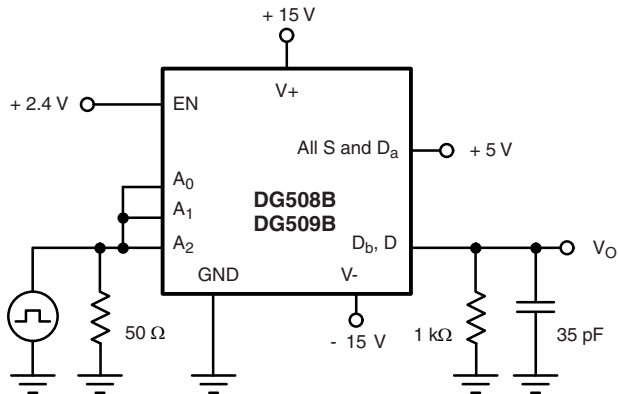
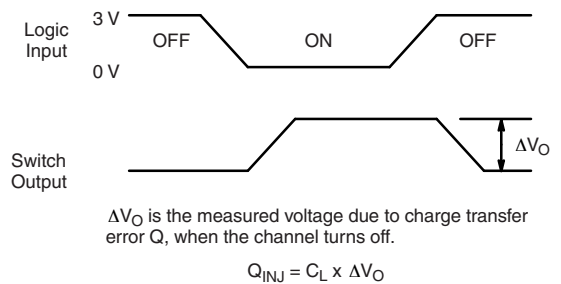
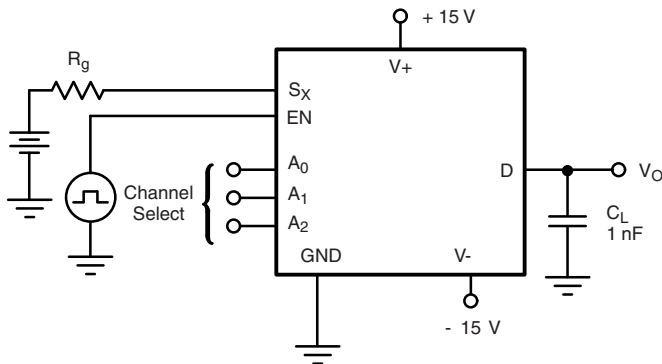
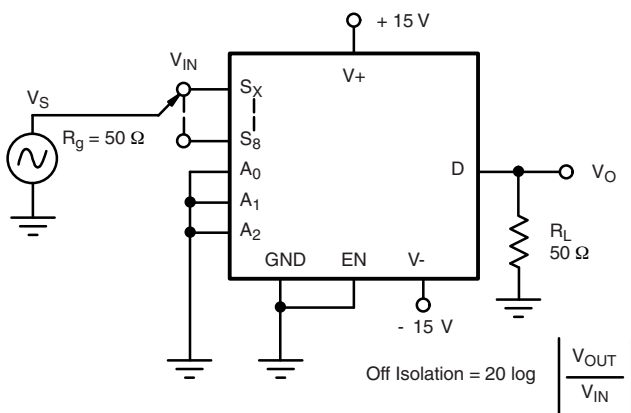
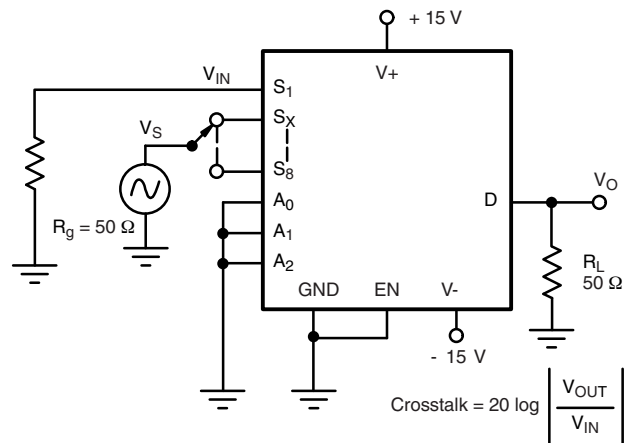

Figure 3. Enable Switching Time

TEST CIRCUITS

Figure 4. Break-Before-Make Interval

Figure 5. Charge Injection

Figure 6. Off Isolation

$$\text{Off Isolation} = 20 \log \left| \frac{V_{OUT}}{V_{IN}} \right|$$

Figure 7. Crosstalk

$$\text{Crosstalk} = 20 \log \left| \frac{V_{OUT}}{V_{IN}} \right|$$

TEST CIRCUITS

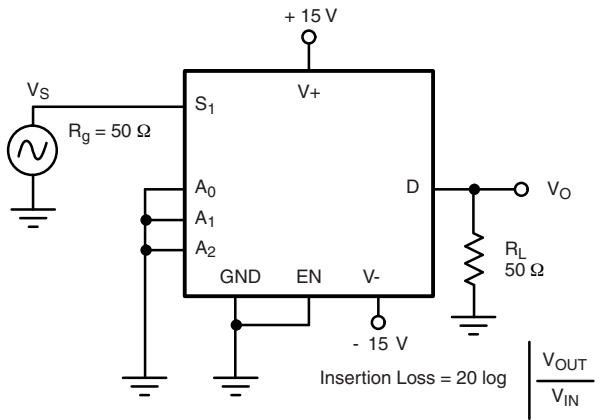

Figure 8. Insertion Loss

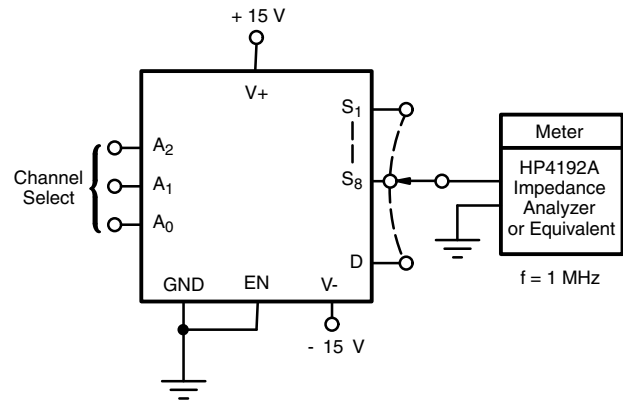
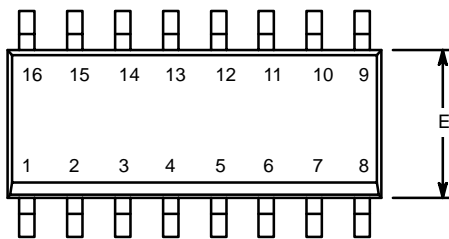

Figure 9. Source Drain Capacitance

Vishay Siliconix maintains worldwide manufacturing capability. Products may be manufactured at one of several qualified locations. Reliability data for Silicon Technology and Package Reliability represent a composite of all qualified locations. For related documents such as package/tape drawings, part marking, and reliability data, see www.vishay.com/ppq?64821.



SOIC (NARROW): 16-LEAD
JEDEC Part Number: MS-012



Dim	MILLIMETERS		INCHES	
	Min	Max	Min	Max
A	1.35	1.75	0.053	0.069
A ₁	0.10	0.20	0.004	0.008
B	0.38	0.51	0.015	0.020
C	0.18	0.23	0.007	0.009
D	9.80	10.00	0.385	0.393
E	3.80	4.00	0.149	0.157
e	1.27 BSC		0.050 BSC	
H	5.80	6.20	0.228	0.244
L	0.50	0.93	0.020	0.037
∅	0°	8°	0°	8°

ECN: S-03946—Rev. F, 09-Jul-01
DWG: 5300

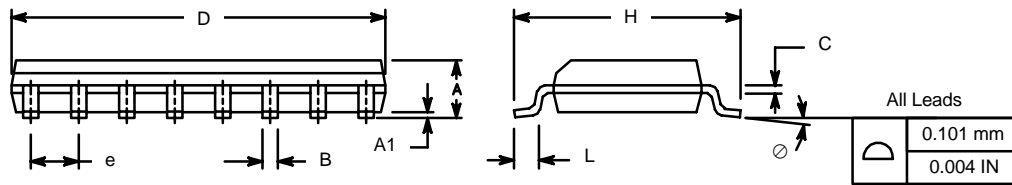

PDIP: 16-LEAD

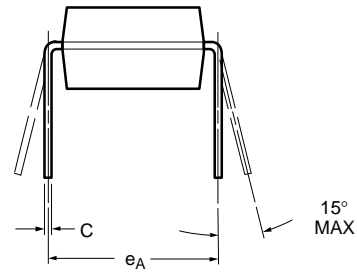
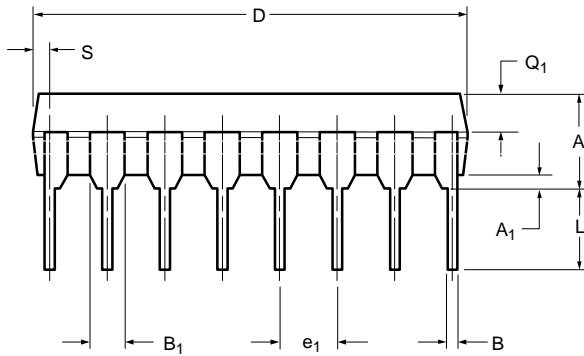
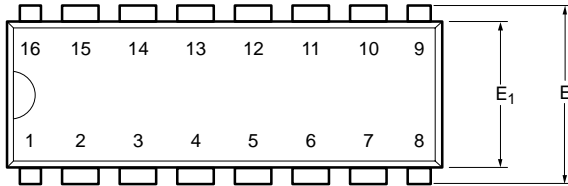

Dim	MILLIMETERS		INCHES	
	Min	Max	Min	Max
A	3.81	5.08	0.150	0.200
A₁	0.38	1.27	0.015	0.050
B	0.38	0.51	0.015	0.020
B₁	0.89	1.65	0.035	0.065
C	0.20	0.30	0.008	0.012
D	18.93	21.33	0.745	0.840
E	7.62	8.26	0.300	0.325
E₁	5.59	7.11	0.220	0.280
e₁	2.29	2.79	0.090	0.110
e_A	7.37	7.87	0.290	0.310
L	2.79	3.81	0.110	0.150
Q₁	1.27	2.03	0.050	0.080
S	0.38	1.52	.015	0.060

ECN: S-03946—Rev. D, 09-Jul-01
DWG: 5482

MINI QFN-16L

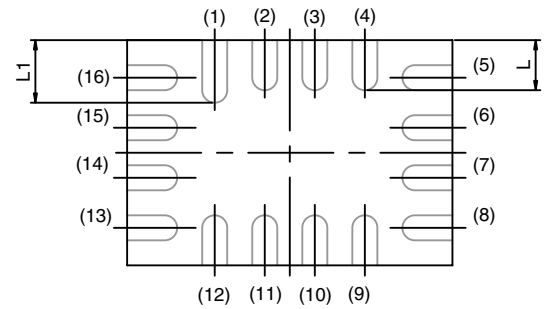
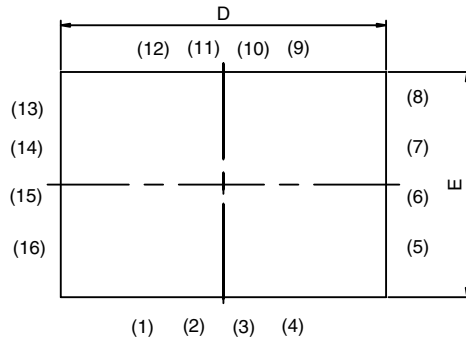

BACK SIDE VIEW

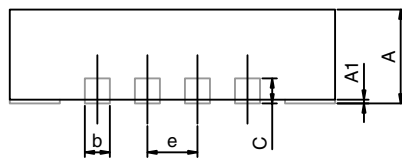

DIM	MILLIMETERS			INCHES		
	MIN.	NAM	MAX.	MIN.	NAM	MAX.
A	0.70	0.75	0.80	0.0275	0.0295	0.0315
A1	0	-	0.05	0	-	0.002
b	0.15	0.20	0.25	0.0059	0.0078	0.0098
C	0.15	0.20	0.25	0.0059	0.0078	0.0098
D	2.60 BSC			0.1023 BSC		
E	1.80 BSC			0.0708 BSC		
e	0.40 BSC			0.0157 BSC		
L	0.35	0.40	0.45	0.0137	0.0157	0.0177
L1	0.45	0.50	0.55	0.0177	0.0196	0.0216

ECN T-06380-Rev. A, 14-Aug-06
DWG: 5954

TSSOP: 16-LEAD

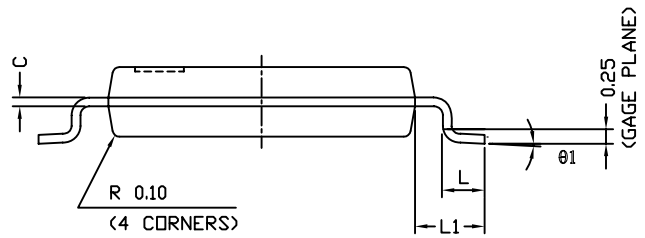
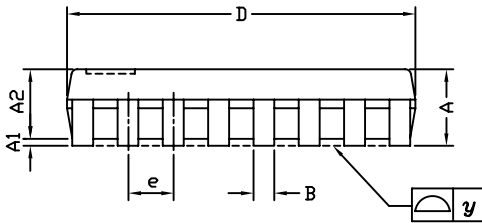
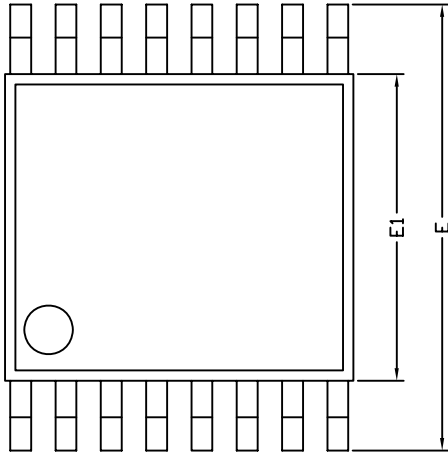

Symbols	DIMENSIONS IN MILLIMETERS		
	Min	Nom	Max
A	-	1.10	1.20
A1	0.05	0.10	0.15
A2	-	1.00	1.05
B	0.22	0.28	0.38
C	-	0.127	-
D	4.90	5.00	5.10
E	6.10	6.40	6.70
E1	4.30	4.40	4.50
e	-	0.65	-
L	0.50	0.60	0.70
L1	0.90	1.00	1.10
y	-	-	0.10
θ1	0°	3°	6°

ECN: S-61920-Rev. D, 23-Oct-06
DWG: 5624



RECOMMENDED MINIMUM PAD FOR TSSOP-16

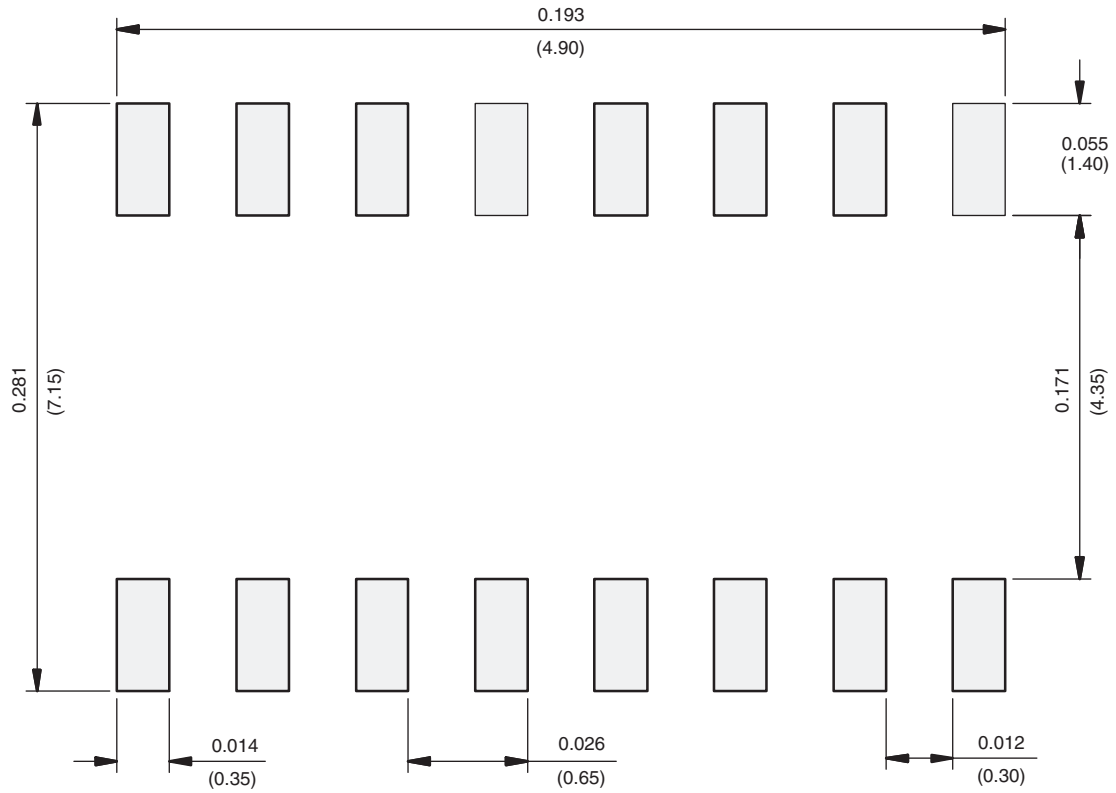

Recommended Minimum Pads
Dimensions in inches (mm)

RECOMMENDED MINIMUM PADS FOR SO-16

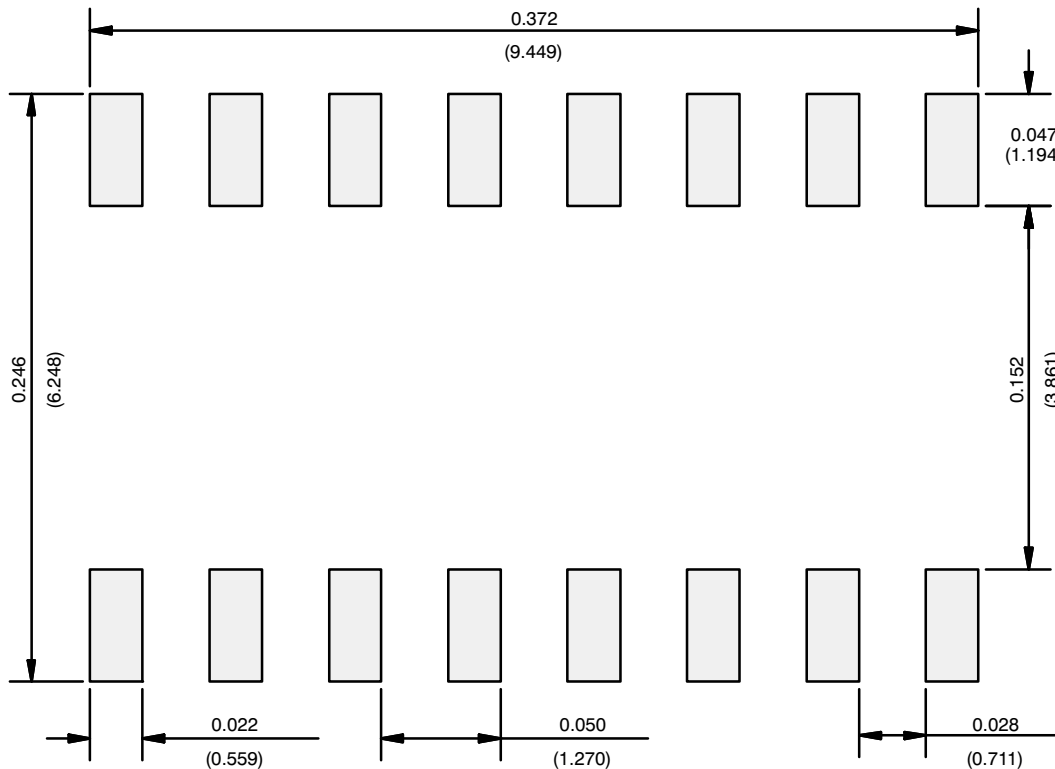

Recommended Minimum Pads
Dimensions in Inches/(mm)

[Return to Index](#)



Disclaimer

ALL PRODUCT, PRODUCT SPECIFICATIONS AND DATA ARE SUBJECT TO CHANGE WITHOUT NOTICE TO IMPROVE RELIABILITY, FUNCTION OR DESIGN OR OTHERWISE.

Vishay Intertechnology, Inc., its affiliates, agents, and employees, and all persons acting on its or their behalf (collectively, "Vishay"), disclaim any and all liability for any errors, inaccuracies or incompleteness contained in any datasheet or in any other disclosure relating to any product.

Vishay makes no warranty, representation or guarantee regarding the suitability of the products for any particular purpose or the continuing production of any product. To the maximum extent permitted by applicable law, Vishay disclaims (i) any and all liability arising out of the application or use of any product, (ii) any and all liability, including without limitation special, consequential or incidental damages, and (iii) any and all implied warranties, including warranties of fitness for particular purpose, non-infringement and merchantability.

Statements regarding the suitability of products for certain types of applications are based on Vishay's knowledge of typical requirements that are often placed on Vishay products in generic applications. Such statements are not binding statements about the suitability of products for a particular application. It is the customer's responsibility to validate that a particular product with the properties described in the product specification is suitable for use in a particular application. Parameters provided in datasheets and/or specifications may vary in different applications and performance may vary over time. All operating parameters, including typical parameters, must be validated for each customer application by the customer's technical experts. Product specifications do not expand or otherwise modify Vishay's terms and conditions of purchase, including but not limited to the warranty expressed therein.

Except as expressly indicated in writing, Vishay products are not designed for use in medical, life-saving, or life-sustaining applications or for any other application in which the failure of the Vishay product could result in personal injury or death. Customers using or selling Vishay products not expressly indicated for use in such applications do so at their own risk. Please contact authorized Vishay personnel to obtain written terms and conditions regarding products designed for such applications.

No license, express or implied, by estoppel or otherwise, to any intellectual property rights is granted by this document or by any conduct of Vishay. Product names and markings noted herein may be trademarks of their respective owners.

Material Category Policy

Vishay Intertechnology, Inc. hereby certifies that all its products that are identified as RoHS-Compliant fulfill the definitions and restrictions defined under Directive 2011/65/EU of The European Parliament and of the Council of June 8, 2011 on the restriction of the use of certain hazardous substances in electrical and electronic equipment (EEE) - recast, unless otherwise specified as non-compliant.

Please note that some Vishay documentation may still make reference to RoHS Directive 2002/95/EC. We confirm that all the products identified as being compliant to Directive 2002/95/EC conform to Directive 2011/65/EU.

Vishay Intertechnology, Inc. hereby certifies that all its products that are identified as Halogen-Free follow Halogen-Free requirements as per JEDEC JS709A standards. Please note that some Vishay documentation may still make reference to the IEC 61249-2-21 definition. We confirm that all the products identified as being compliant to IEC 61249-2-21 conform to JEDEC JS709A standards.