

Optocoupler, Photodarlington Output (Single, Dual, Quad Channel)

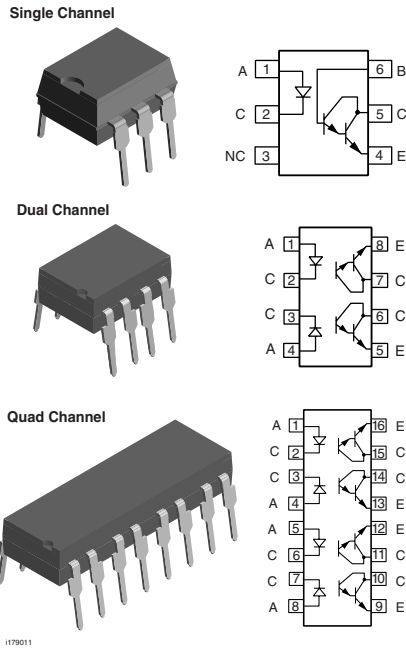

FEATURES

- 125 mA load current rating
- Fast rise time, 10 μ s
- Fast fall time, 35 μ s
- Single, dual and quad channel
- Solid state reliability
- Standard DIP packages
- Lead (Pb)-free component
- Component in accordance to RoHS 2002/95/EC and WEEE 2002/96/EC



RoHS
COMPLIANT

AGENCY APPROVALS

- UL1577, file no. E52744 system code H or J, double protection
- DIN EN 60747-5-2 (VDE 0884)/DIN EN 60747-5-5 pending available with option 1
- BSI IEC 60950 IEC 60065
- FIMKO

DESCRIPTION

The IL30/IL31/IL55 single, IL30/IL31/IL55 dual, and ILQ30/ILQ31/ILQ55 quad are optically coupled isolators with gallium arsenide infrared emitters and silicon photodarlington sensors. Switching can be achieved while maintaining a high degree of isolation between driving and load circuits, with no crosstalk between channels. These optocouplers can be used to replace reed and mercury relays with advantages of long life, high speed switching and elimination of magnetic fields.

The IL30/IL31/IL55 are equivalent to MCA230/MCA231/MCA255. The IL30/IL31/IL55 are equivalent to MCA230/MCA231/MCA255. The IL30/IL31/IL55 are designed to reduce board space requirements in high density applications.

ORDER INFORMATION	
PART	REMARKS
IL30	CTR > 100 %, single channel DIP-6
IL31	CTR > 200 %, single channel DIP-6
IL55	CTR > 100 %, single channel DIP-6
ILD30	CTR > 100 %, dual channel DIP-8
ILD31	CTR > 200 %, dual channel DIP-8
ILD55	CTR > 100 %, dual channel DIP-8
ILQ30	CTR > 100 %, quad channel DIP-16
ILQ31	CTR > 200 %, quad channel DIP-16
ILQ55	CTR > 100 %, quad channel DIP-16
IL55-X009	CTR > 100 %, single channel SMD-6 (option 9)
ILD30-X009	CTR > 100 %, dual channel SMD-8 (option 9)
ILD31-X007	CTR > 200 %, dual channel SMD-8 (option 7)
ILD31-X009	CTR > 200 %, dual channel SMD-8 (option 9)

IL30/IL31/IL55/ILD30/ILD31/ILD55/ILQ30/ILQ31/ILQ55



Vishay Semiconductors Optocoupler, Photodarlington Output
(Single, Dual, Quad Channel)

ORDER INFORMATION	
PART	REMARKS
ILD55-X007	CTR > 100 %, dual channel SMD-8 (option 7)
ILD55-X009	CTR > 100 %, dual channel SMD-8 (option 9)
ILQ30-X009	CTR > 100 %, quad channel SMD-16 (option 9)
ILQ55-X007	CTR > 100 %, quad channel SMD-16 (option 7)
ILQ55-X009	CTR > 100 %, quad channel SMD-16 (option 9)

Note

For additional information on the available options refer to option information.

ABSOLUTE MAXIMUM RATINGS					
PARAMETER	TEST CONDITION	PART	SYMBOL	VALUE	UNIT
INPUT					
Peak reverse voltage			V_{RM}	3.0	V
Forward continuous current			I_F	60	mA
Power dissipation			P_{diss}	100	mW
Derate linearly from 25 °C				1.33	mW/°C
OUTPUT					
Collector emitter breakdown voltage		IL30	BV_{CEO}	30	V
		ILD30	BV_{CEO}	30	V
		ILQ30	BV_{CEO}	30	V
		IL55	BV_{CEO}	55	V
		ILD55	BV_{CEO}	55	V
		ILD55	BV_{CEO}	55	V
Collector (load) current			I_C	125	mA
Power dissipation			P_{diss}	150	mW
Derate linearly from 25 °C				2.0	mW/°C
COUPLER					
Total package power dissipation		IL30	P_{tot}	250	mW
		IL31	P_{tot}	250	mW
		IL55	P_{tot}	250	mW
		ILD30	P_{tot}	400	mW
		ILD31	P_{tot}	400	mW
		ILD55	P_{tot}	400	mW
		ILQ30	P_{tot}	500	mW
		ILQ31	P_{tot}	500	mW
Derate linearly from 25 °C		IL30		3.3	mW/°C
		IL31		3.3	mW/°C
		IL55		3.3	mW/°C
		ILD30		5.33	mW/°C
		ILD31		5.33	mW/°C
		ILD55		5.33	mW/°C
		ILQ30		6.67	mW/°C
		ILQ31		6.67	mW/°C
Isolation test voltage			V_{ISO}	5300	V_{RMS}
		Creepage distance		≥ 7.0	mm
		Clearance distance		≥ 7.0	mm
		Comparative tracking index		CTI	175
Storage temperature			T_{stg}	- 55 to + 125	°C



IL30/IL31/IL55/ILD30/ILD31/ILD55/ILQ30/ILQ31/ILQ55

Optocoupler, Photodarlington Output Vishay Semiconductors
(Single, Dual, Quad Channel)

ABSOLUTE MAXIMUM RATINGS					
PARAMETER	TEST CONDITION	PART	SYMBOL	VALUE	UNIT
COUPLER					
Operating temperature			T_{amb}	- 55 to + 100	°C
Lead soldering time at 260 °C				10	s

Note

$T_{amb} = 25\text{ °C}$, unless otherwise specified.

Stresses in excess of the absolute maximum ratings can cause permanent damage to the device. Functional operation of the device is not implied at these or any other conditions in excess of those given in the operational sections of this document. Exposure to absolute maximum ratings for extended periods of the time can adversely affect reliability.

ELECTRICAL CHARACTERISTICS						
PARAMETER	TEST CONDITION	SYMBOL	MIN.	TYP.	MAX.	UNIT
INPUT						
Forward voltage	$I_F = 20\text{ mA}$	V_F		1.25	1.5	V
Reverse current	$V_R = 3.0\text{ V}$	I_R		0.1	10	μA
Capacitance	$V_R = 0\text{ V}$	C_O		25		pF
OUTPUT						
Collector emitter breakdown voltage	$I_C = 100\text{ μA}$	BV_{CEO}	30/55			V
Collector emitter leakage current	$V_{CE} = 10\text{ V}, I_F = 0\text{ A}$	I_{CEO}		1.0	100	nA
Collector emitter capacitance	$V_{CE} = 10\text{ V}, f = 1.0\text{ MHz}$	C_{CE}		3.4		pF
COUPLER						
Collector emitter saturation voltage	$I_C = 50\text{ mA}, I_F = 50\text{ mA}$	V_{CEsat}		0.9	1.0	V
Isolation test voltage			5300			V_{RMS}
Isolation resistance		R_{IO}		10^{12}		Ω
Capacitance (input to output)		C_{IO}		0.5		pF

Note

$T_{amb} = 25\text{ °C}$, unless otherwise specified.

Minimum and maximum values are testing requirements. Typical values are characteristics of the device and are the result of engineering evaluation. Typical values are for information only and are not part of the testing requirements.

CURRENT TRANSFER RATIO							
PARAMETER	TEST CONDITION	PART	SYMBOL	MIN.	TYP.	MAX.	UNIT
Current transfer ratio	$I_F = 10\text{ mA}, V_{CE} = 5.0\text{ V}$	IL30	CTR	100	400		%
		IL55	CTR	100	400		%
		ILD30	CTR	100	400		%
		ILD55	CTR	100	400		%
		ILQ30	CTR	100	400		%
		ILQ55	CTR	100	400		%
		IL31	CTR	200	400		%
		ILD31	CTR	200	400		%
ILQ31	CTR	200	400		%		

SWITCHING CHARACTERISTICS						
PARAMETER	TEST CONDITION	SYMBOL	MIN.	TYP.	MAX.	UNIT
Rise time	$V_{CC} = 13.5\text{ V}, I_F = 50\text{ mA}, R_L = 100\text{ Ω}$	t_r		10		μs
Fall time	$V_{CC} = 13.5\text{ V}, I_F = 50\text{ mA}, R_L = 100\text{ Ω}$	t_f		35		μs

TYPICAL CHARACTERISTICS

$T_{amb} = 25\text{ }^{\circ}\text{C}$, unless otherwise specified

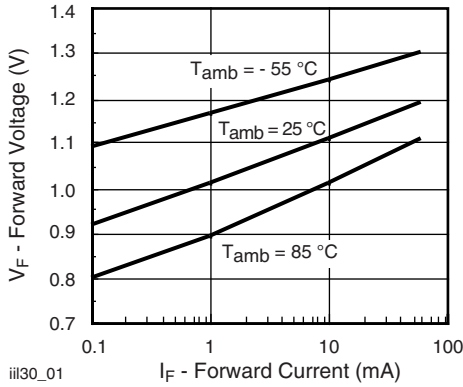

Fig. 1 - Forward Voltage vs. Forward Current

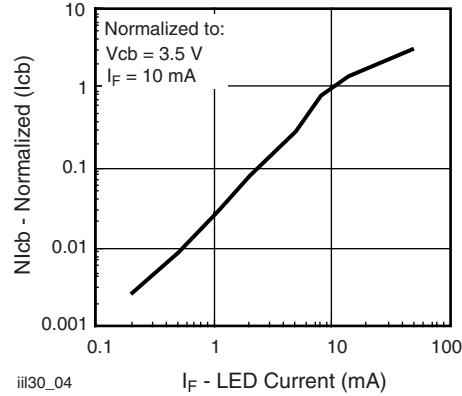

Fig. 4 - Normalized Collector Base Photocurrent vs. LED Current

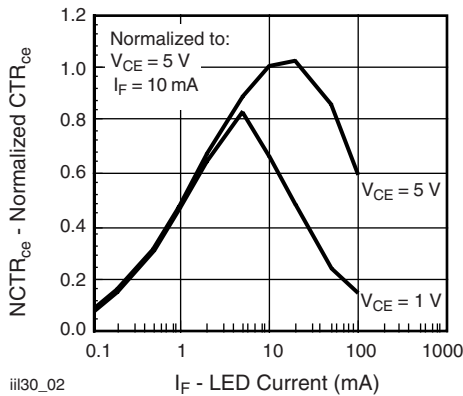

Fig. 2 - Normalized Non-Saturated and Saturated CTR_{CE} vs. LED Current

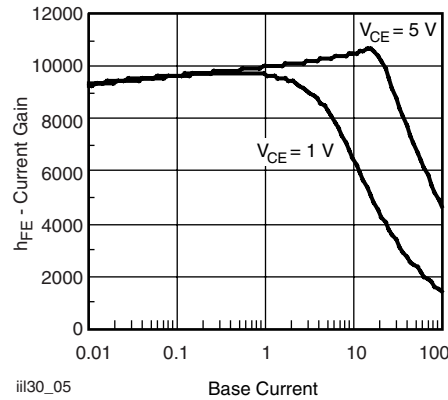

Fig. 5 - h_{FE} Current Gain vs. Base Current

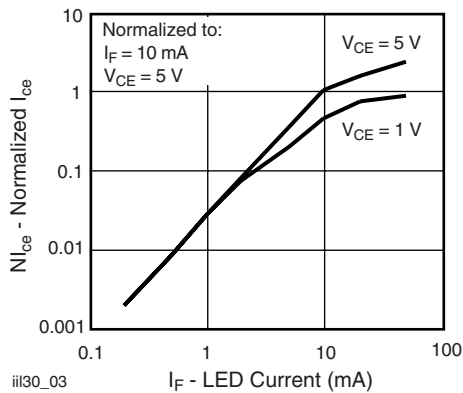

Fig. 3 - Normalized Non-Saturated and Saturated Collector Emitter Current vs. LED Current

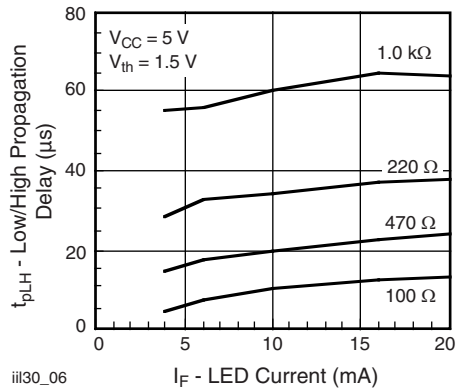

Fig. 6 - Low to High Propagation Delay vs. Collector Load Resistance and LED Current



IL30/IL31/IL55/ILD30/ILD31/ILD55/ILQ30/ILQ31/ILQ55

Optocoupler, Photodarlington Output
(Single, Dual, Quad Channel)

Vishay Semiconductors

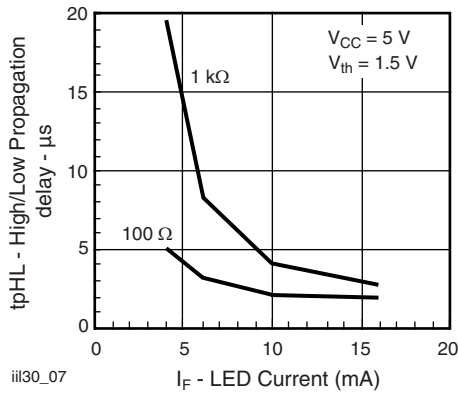
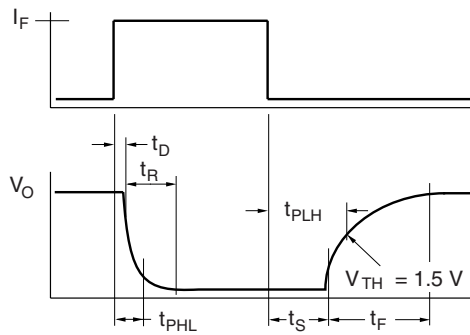
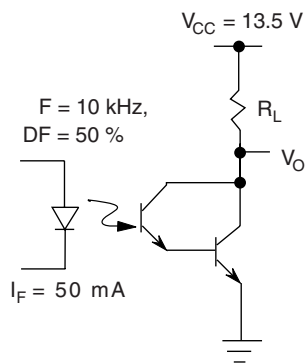

Fig. 7 - High to Low Propagation Delay vs. Collector Load Resistance and LED Current



iii30_08

Fig. 8 - Switching Waveform



iii30_09

Fig. 9 - Switching Schematic

IL30/IL31/IL55/ILD30/ILD31/ILD55/ILQ30/ILQ31/ILQ55



Vishay Semiconductors Optocoupler, Photodarlington Output
(Single, Dual, Quad Channel)

PACKAGE DIMENSIONS in inches (millimeters)

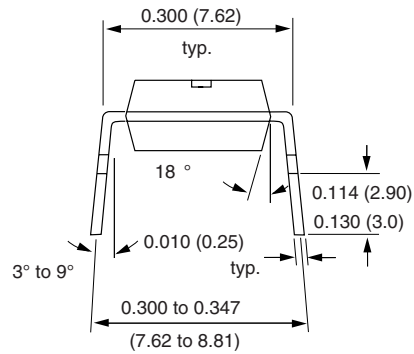
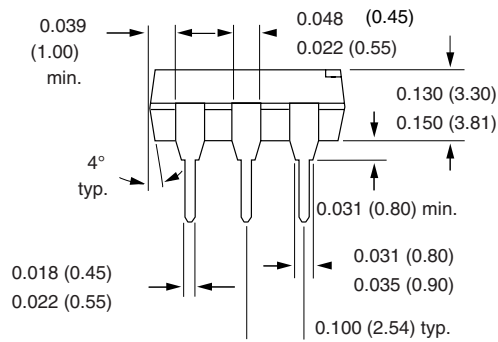
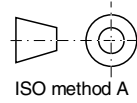
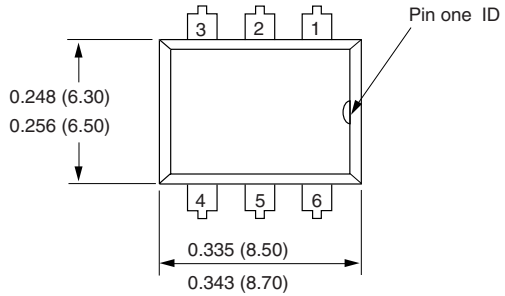

i178004

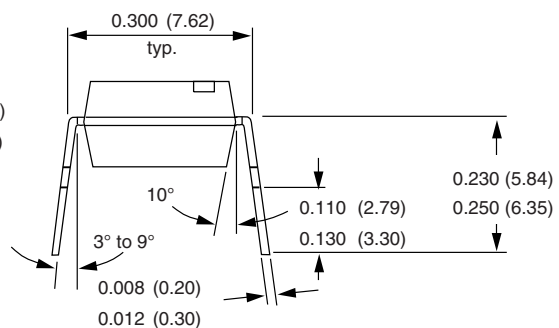
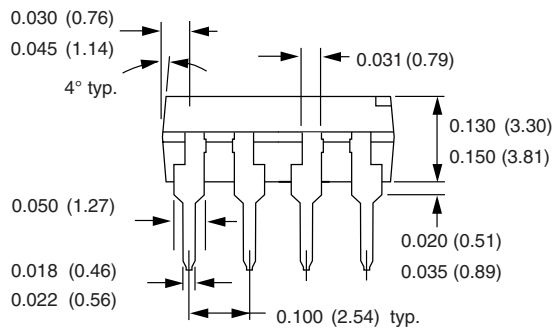
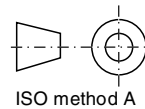
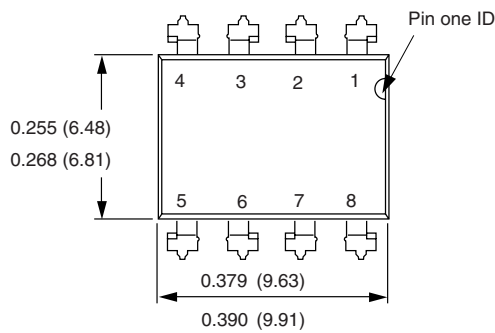

i178006



IL30/IL31/IL55/ILD30/ILD31/ILD55/ILQ30/ILQ31/ILQ55

Optocoupler, Photodarlington Output
(Single, Dual, Quad Channel)

Vishay Semiconductors

PACKAGE DIMENSIONS in inches (millimeters)

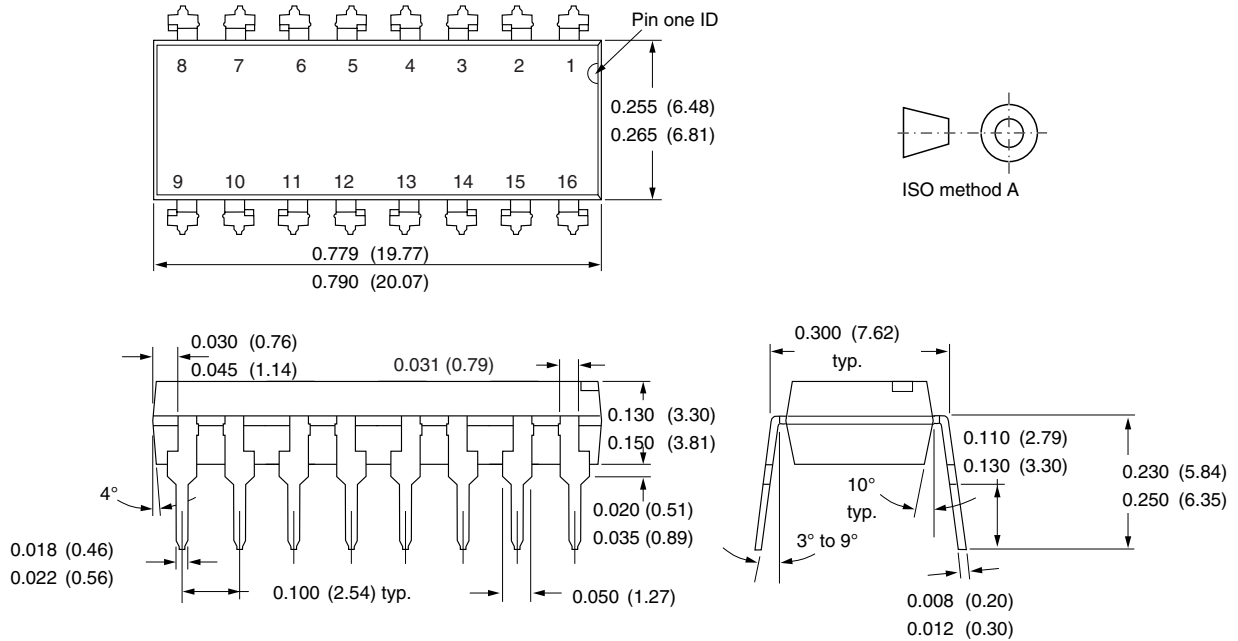

i178007

Option 7

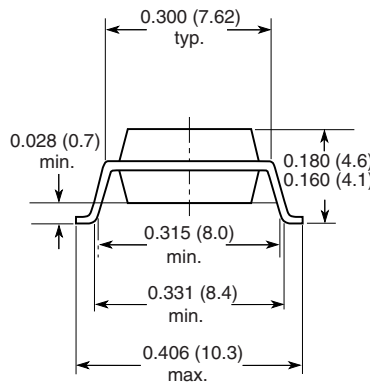

Option 9

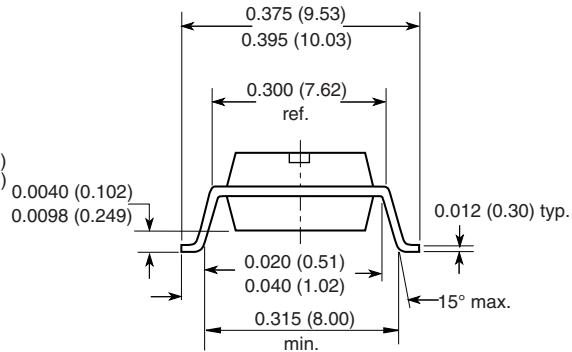

18494

OZONE DEPLETING SUBSTANCES POLICY STATEMENT

It is the policy of Vishay Semiconductor GmbH to

1. Meet all present and future national and international statutory requirements.
2. Regularly and continuously improve the performance of our products, processes, distribution and operating systems with respect to their impact on the health and safety of our employees and the public, as well as their impact on the environment.

It is particular concern to control or eliminate releases of those substances into the atmosphere which are known as ozone depleting substances (ODSs).

The Montreal Protocol (1987) and its London Amendments (1990) intend to severely restrict the use of ODSs and forbid their use within the next ten years. Various national and international initiatives are pressing for an earlier ban on these substances.

Vishay Semiconductor GmbH has been able to use its policy of continuous improvements to eliminate the use of ODSs listed in the following documents.

1. Annex A, B and list of transitional substances of the Montreal Protocol and the London Amendments respectively.
2. Class I and II ozone depleting substances in the Clean Air Act Amendments of 1990 by the Environmental Protection Agency (EPA) in the USA.
3. Council Decision 88/540/EEC and 91/690/EEC Annex A, B and C (transitional substances) respectively.

Vishay Semiconductor GmbH can certify that our semiconductors are not manufactured with ozone depleting substances and do not contain such substances.

We reserve the right to make changes to improve technical design
and may do so without further notice.

Parameters can vary in different applications. All operating parameters must be validated for each customer application by the customer. Should the buyer use Vishay Semiconductors products for any unintended or unauthorized application, the buyer shall indemnify Vishay Semiconductors against all claims, costs, damages, and expenses, arising out of, directly or indirectly, any claim of personal damage, injury or death associated with such unintended or unauthorized use.

Vishay Semiconductor GmbH, P.O.B. 3535, D-74025 Heilbronn, Germany



Disclaimer

ALL PRODUCT, PRODUCT SPECIFICATIONS AND DATA ARE SUBJECT TO CHANGE WITHOUT NOTICE TO IMPROVE RELIABILITY, FUNCTION OR DESIGN OR OTHERWISE.

Vishay Intertechnology, Inc., its affiliates, agents, and employees, and all persons acting on its or their behalf (collectively, "Vishay"), disclaim any and all liability for any errors, inaccuracies or incompleteness contained in any datasheet or in any other disclosure relating to any product.

Vishay makes no warranty, representation or guarantee regarding the suitability of the products for any particular purpose or the continuing production of any product. To the maximum extent permitted by applicable law, Vishay disclaims (i) any and all liability arising out of the application or use of any product, (ii) any and all liability, including without limitation special, consequential or incidental damages, and (iii) any and all implied warranties, including warranties of fitness for particular purpose, non-infringement and merchantability.

Statements regarding the suitability of products for certain types of applications are based on Vishay's knowledge of typical requirements that are often placed on Vishay products in generic applications. Such statements are not binding statements about the suitability of products for a particular application. It is the customer's responsibility to validate that a particular product with the properties described in the product specification is suitable for use in a particular application. Parameters provided in datasheets and/or specifications may vary in different applications and performance may vary over time. All operating parameters, including typical parameters, must be validated for each customer application by the customer's technical experts. Product specifications do not expand or otherwise modify Vishay's terms and conditions of purchase, including but not limited to the warranty expressed therein.

Except as expressly indicated in writing, Vishay products are not designed for use in medical, life-saving, or life-sustaining applications or for any other application in which the failure of the Vishay product could result in personal injury or death. Customers using or selling Vishay products not expressly indicated for use in such applications do so at their own risk and agree to fully indemnify and hold Vishay and its distributors harmless from and against any and all claims, liabilities, expenses and damages arising or resulting in connection with such use or sale, including attorneys fees, even if such claim alleges that Vishay or its distributor was negligent regarding the design or manufacture of the part. Please contact authorized Vishay personnel to obtain written terms and conditions regarding products designed for such applications.

No license, express or implied, by estoppel or otherwise, to any intellectual property rights is granted by this document or by any conduct of Vishay. Product names and markings noted herein may be trademarks of their respective owners.