

DNR05-60 Series



- Rugged Design for Industrial Applications
- Up to 89% Efficiency
- Full Power to +60 °C
- Wide Adjustment Range
- DC OK 24 V Models
- DC Standby Versions
- 3 Year Warranty

Specification

Input

Input Voltage	• 90-264 VAC, 120-370 VDC (DNR05/10/18) 85-264 VAC, 90-375 VDC (DNR30/60)
Input Frequency	• 47-63 Hz
Inrush Current	• 5-18 W: 10/18 A at 115/230 VAC 30 W: 20/40 A at 115/230 VAC 60 W: 30/60 A at 115/230 VAC
Power Factor	• Meets EN61000-3-2 for class A equipment
Earth Leakage Current	• 0.8 mA max
Input Protection	• Internal fuse T2A, 250 VAC

Output

Output Voltage	• See tables
Output Voltage Trim	• See tables
Initial Set Accuracy	• $\pm 1\%$
Minimum Load	• No minimum load required
Start Up Delay	• <1000 ms (may increase at low temperature extremes)
Start Up Rise Time	• <150 ms
Hold Up Time	• 30/130 ms at 115/230 VAC (DNR05) 25/100 ms at 115/230 VAC (DNR10) 20/75 ms at 115/230 VAC (DNR18) 20/30 ms at 115/230 VAC (DNR30) 20/30 ms at 115/230 VAC DNR60)
Line Regulation	• 5-18 W: $\pm 1.0\%$ max 30-60 W: $\pm 0.5\%$ max
Load Regulation	• 5-18 W: $\pm 2.0\%$ max 30-60 W: $\pm 0.5\%$ max
Parallel Operation	• Redundancy module available for load currents up to 10 A, contact sales.
Transient Response	• 4% max deviation recovering to within 1% in 1 ms for a 50% load change
Ripple & Noise	• 50 mV pk-pk, 20 MHz bandwidth (may increase at low temperature extremes)
Overvoltage Protection	• Output clamps at 120-145% Vnom, auto recovery
Overload Protection	• 105-145%
Short Circuit Protection	• 5-18 W: Trip and restart (Hiccup mode) 30-60 W: Constant power, auto recovery
Temperature Coefficient	• $\pm 0.03\%/^{\circ}\text{C}$

General

Efficiency	• See tables
Isolation	• 3000 VAC Input to Output 1500 VAC Input to Ground 500 VAC Output to Ground
Switching Frequency	• 100 KHz typical
Signals	• DC ON indicator LED Green: All models DC LOW indicator LED Red: 5-18 W models DC OK: 24 V 30-60 W models
MTBF	• 780 kHrs typical Bellcore, Issue 6 at +40 °C, GB (DNR05/10/18) 530 kHrs typical Bellcore, Issue 6 at +40 °C, GB (DNR30/60)

Environmental

Operating Temperature	• -25 °C to +70 °C, derate linearly from +50 °C for 5 & 18 W models, +60 °C for all other models (See derating curves)
Cooling	• Convection-cooled with 25mm free space all sides
Operating Humidity	• 20-95% RH, non-condensing
Storage Temperature	• -25 °C to +85 °C
Shock	• 4 g, 22 ms, X, Y & Z axis
Vibration	• 1 g, 10 Hz to 500 kHz, along X, Y & Z axis

EMC & Safety

Emissions	• EN55022, level B conducted
Harmonic Currents	• EN61000-3-2, class A
Voltage Flicker	• EN61000-3-3 amendments 1 & 2
ESD Immunity	• EN61000-4-2, level 3 Perf Criteria A
Radiated Immunity	• EN61000-4-3, level 3 Perf Criteria A
EFT/Burst	• EN61000-4-4, level 3 Perf Criteria A
Surge	• EN61000-4-5, level 3 Perf Criteria A
Dips & Interruptions	• EN61000-4-11, 30% 10 ms, 60% 100 ms, 100% 5000 ms Perf Criteria A, B, B
Safety Approvals	• EN60950-1, UL508, Pollution Degree 2, UL1310 - see note 3 & ratings table, UL60950-1, Overvoltage Category II, UL508, Overvoltage Category III, DNR30 & DNR60: SEMI F47

Mechanical Details
5/10/18 W Models

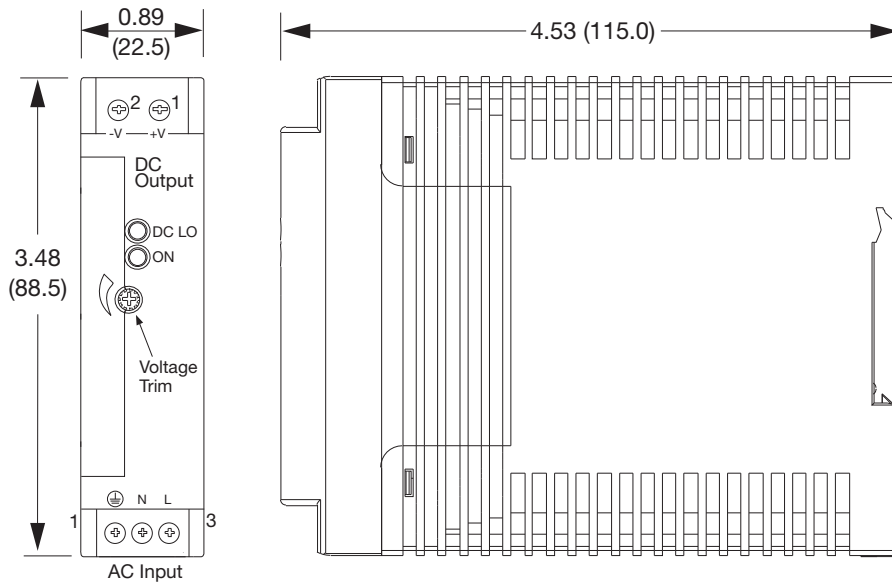

Notes

1. All dimensions in inches (mm).
2. Tolerance: ± 0.02 (0.5) maximum.
3. Weight 0.33 lb (150 g) approx.
4. Connection screw maximum torque:
Input: 9 lbs-in (1.0 Nm), Output: 5.5 lbs-in (0.6 Nm)

DNR05, 10, 18 Connections		
Conn	Pin	Designation
AC Input	1	Ground
	2	Neutral
	3	Line
DC Output	1	Positive
	2	Negative

30/60 W Models

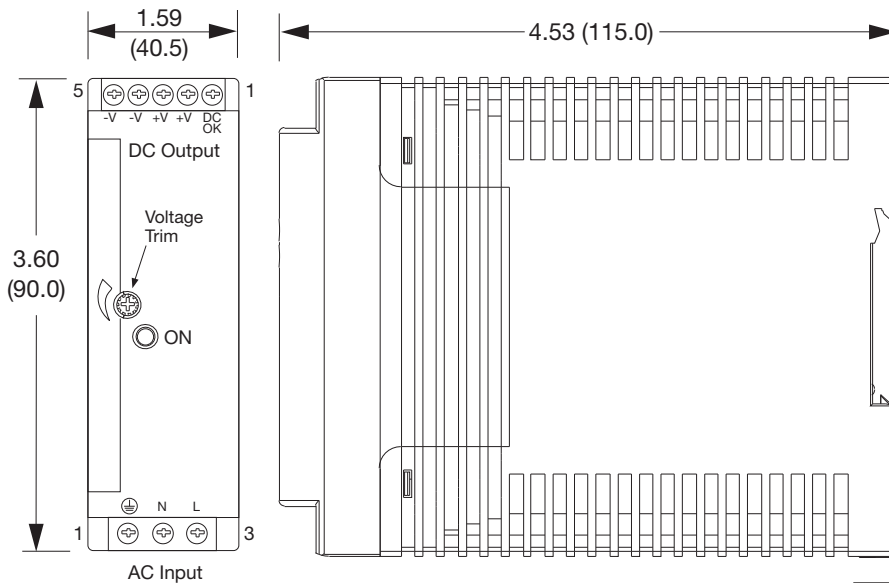

Notes

1. All dimensions in inches (mm).
2. Tolerance: ± 0.02 (0.5) maximum.
3. Weight 0.8 lb (350 g) approx.
4. Connection screw maximum torque:
Input: 9 lbs-in (1.0 Nm), Output: 5.5 lbs-in (0.6 Nm)

DNR30/60 Connections		
Conn	Pin	Designation
AC Input	1	Ground
	2	Neutral
	3	Line
DC Output	1	DC OK*
	2	Positive
	3	Positive
	4	Negative
	5	Negative

* 24 V models only.

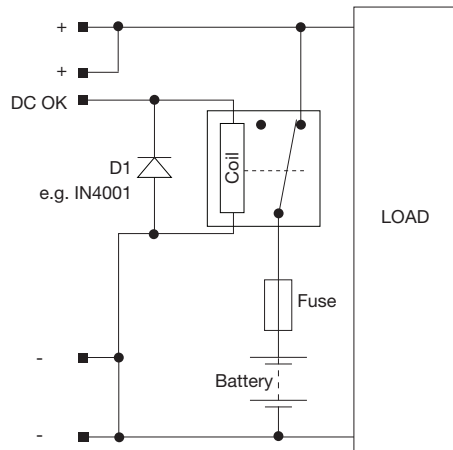
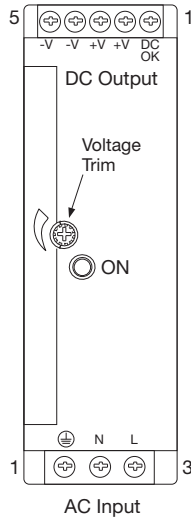

Maximum current drain from battery by PSU when inactive 22 mA.

DNR30/60 Connections		
Conn	Pin	Designation
AC Input	1	Ground
	2	Neutral
	3	Line
DC Output	1	DC OK
	2	Positive
	3	Positive
	4	Negative
	5	Negative

DNR30/60 connection for DC standby system applications

Output Set Voltages For Standby Versions			
Model ⁽¹⁾	Voltage	Current	Efficiency
DNR30US12#	13.6 V	2.20 A	84%
DNR30US24#	27.2 V	1.10 A	86%
DNR30US48#	54.5 V	0.55 A	86%
DNR60US12#	13.6 V	4.40 A	86%
DNR60US24#	27.2 V	2.20 A	89%
DNR60US48#	54.5 V	1.10 A	89%

1. Suffix # indicates standby version.

DC OK

30-60 W Models

Output good = 24 V

Output not good = 0 V

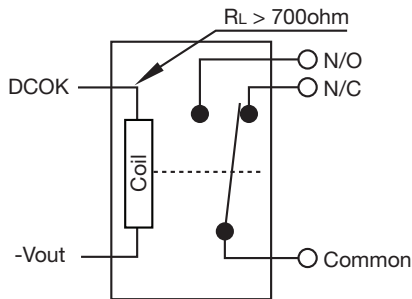

Example using external relay to create volt-free contact

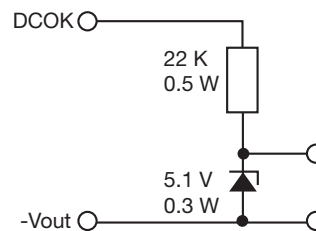

Example using external components to create TTL signal

Standard on 24 V models, 30-60 W only.