

16Gb DDR5 SDRAM Addendum

MT60B4G4, MT60B2G8, MT60B1G16 Die Revision A

Features

This document describes the product specifications that are unique to Micron 16Gb DDR5 Die Revision A device. For general Micron DDR5 SDRAM specifications, see the Micron DDR5 SDRAM Core Product Data Sheet. Content in this 16Gb Die Revision A DDR5 SDRAM data sheet addendum supersedes content defined in the core data sheet.

- $V_{DD} = V_{DDQ} = 1.1V$ (NOM)
- $V_{PP} = 1.8V$ (NOM)
- On-die, internal, adjustable V_{REF} generation for DQ, CA, CS
- 1.1V pseudo open-drain I/O
- TC maximum up to 95°C
 - 32ms, 8192-cycle refresh up to 85°C
 - 16ms, 8192-cycle refresh at >85°C to 95°C
- 32 internal banks (x4, x8): 8 groups of 4 banks each
- 16 internal banks (x16): 4 groups of 4 banks each
- 16n-bit prefetch architecture
- 1 cycle/2 cycle command structure
- 2N mode
- All bank and same bank refresh
- Multi-purpose command (MPC)
- CS/CA training mode
- On-die ECC (bounded fault)
- ECC transparency and error scrub
- Decision feedback equalization (DFE)
- Loopback mode
- Command-based non-target (NT) nominal, DQ/DQS park, and dynamic WR on-die termination (ODT)
- sPPR and hPPR capability
- Per-DRAM addressability
- JEDEC JESD-79.5 compliant

Options¹

- **Configuration**
 - 4 Gig x 4
 - 2 Gig x 8
 - 1 Gig x 16
- **FBGA SDP Packages** (Pb-free)
 - x4, x8 82-ball (9mm x 11mm)
 - x16 102-ball (9mm x 14mm)
- **Timing – cycle time**
 - 0.416ns @ CL = 40
- **Operating temperature**
 - Commercial (0°C < T_C < 95°C)
 - Industrial (-40°C < T_C < 95°C)
 - Automotive (-40°C < T_C < 105°C)
- Die Revision

Marking

4G4
2G8
1G16
HB
HC
-48B
None
IT
AT
:A

Notes: 1. Not all options listed can be combined to define an offered product. Use the part catalog search on micron.com for available offerings.

Table 1: Key Timing Parameters

Speed Grade1	Speed Bin	Data Rate (MT/s)	Target CL-nRCD-nRP	t _{AA} (ns)	t _{RCD} (ns)	t _{RP} (ns)
-48B	4800B	4800	40-39-39	16.000	16.000	16.000

Notes: 1. Refer to the Speed Bin Tables for additional details.

Table 2: 16Gb Addressing

Configuration		4Gb x4	2Gb x8	1Gb x16
Bank address	Number of bank groups/number of banks per bank group/number of banks	8 / 4 / 32	8 / 4 / 32	4 / 4 / 16
	Bank group address	BG0-BG2	BG0-BG2	BG0-BG1
	Bank address in a bank group	BA0-BA1	BA0-BA1	BA0-BA1
Row address		R0-R15	R0-R15	R0-R15
Column address		C0-C10	C0-C9	C0-C9
Page size		1KB	1KB	2KB
Chip IDs/maximum stack height		CID0-3 / 16H	CID0-3 / 16H	CID0-3 / 16H

Figure 1: Order Part Number Example

Example Part Number: MT60B2G8HB-48B:A

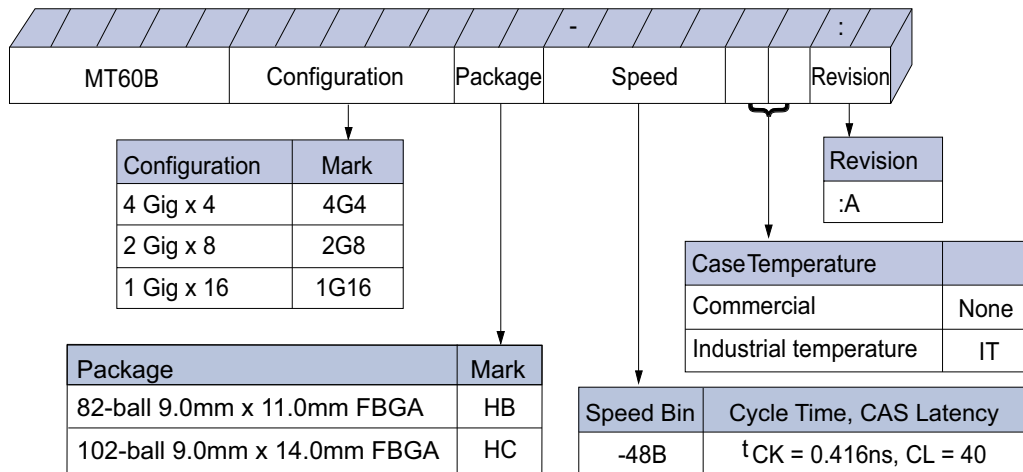

Important Notes and Warnings

Micron Technology, Inc. ("Micron") reserves the right to make changes to information published in this document, including without limitation specifications and product descriptions. This document supersedes and replaces all information supplied prior to the publication hereof. You may not rely on any information set forth in this document if you obtain the product described herein from any unauthorized distributor or other source not authorized by Micron.

Automotive Applications. Products are not designed or intended for use in automotive applications unless specifically designated by Micron as automotive-grade by their respective data sheets. Distributor and customer/distributor shall assume the sole risk and liability for and shall indemnify and hold Micron harmless against all claims, costs, damages, and expenses and reasonable attorneys' fees arising out of, directly or indirectly, any claim of product liability, personal injury, death, or property damage resulting directly or indirectly from any use of non-automotive-grade products in automotive applications. Customer/distributor shall ensure that the terms and conditions of sale between customer/distributor and any customer of distributor/customer (1) state that Micron products are not designed or intended for use in automotive applications unless specifically designated by Micron as automotive-grade by their respective data sheets and (2) require such customer of distributor/customer to indemnify and hold Micron harmless against all claims, costs, damages, and expenses and reasonable attorneys' fees arising out of, directly or indirectly, any claim of product liability, personal injury, death, or property damage resulting from any use of non-automotive-grade products in automotive applications.

Critical Applications. Products are not authorized for use in applications in which failure of the Micron component could result, directly or indirectly in death, personal injury, or severe property or environmental damage ("Critical Applications"). Customer must protect against death, personal injury, and severe property and environmental damage by incorporating safety design measures into customer's applications to ensure that failure of the Micron component will not result in such harms. Should customer or distributor purchase, use, or sell any Micron component for any critical application, customer and distributor shall indemnify and hold harmless Micron and its subsidiaries, subcontractors, and affiliates and the directors, officers, and employees of each against all claims, costs, damages, and expenses and reasonable attorneys' fees arising out of, directly or indirectly, any claim of product liability, personal injury, or death arising in any way out of such critical application, whether or not Micron or its subsidiaries, subcontractors, or affiliates were negligent in the design, manufacture, or warning of the Micron product.

Customer Responsibility. Customers are responsible for the design, manufacture, and operation of their systems, applications, and products using Micron products. ALL SEMICONDUCTOR PRODUCTS HAVE INHERENT FAILURE RATES AND LIMITED USEFUL LIVES. IT IS THE CUSTOMER'S SOLE RESPONSIBILITY TO DETERMINE WHETHER THE MICRON PRODUCT IS SUITABLE AND FIT FOR THE CUSTOMER'S SYSTEM, APPLICATION, OR PRODUCT. Customers must ensure that adequate design, manufacturing, and operating safeguards are included in customer's applications and products to eliminate the risk that personal injury, death, or severe property or environmental damages will result from failure of any semiconductor component.

Limited Warranty. In no event shall Micron be liable for any indirect, incidental, punitive, special or consequential damages (including without limitation lost profits, lost savings, business interruption, costs related to the removal or replacement of any products or rework charges) whether or not such damages are based on tort, warranty, breach of contract or other legal theory, unless explicitly stated in a written agreement executed by Micron's duly authorized representative.

General Notes and Functional Block Diagrams

General Notes

- The functionality and the timing specifications discussed in this data sheet are for the DLL enable mode of operation (normal operation), unless specifically stated otherwise.
- Throughout the data sheet, the various figures and text refer to DQs as "DQ." The DQ term is to be interpreted as any and all DQ collectively, unless specifically stated otherwise.
- The terms "_t" and "_c" are used to represent the true and complement of a differential signal pair. These terms replace the previously used notation of "#" and/or over-bar characters. For example, differential data strobe pair DQS, DQS# is now referred to as DQS_t, DQS_c.
- The term "_n" is used to represent a signal that is active LOW and replaces the previously used "#" and/or overbar characters. For example: CS# is now referred to as CS_n.
- The terms "DQS" and "CK" found throughout the data sheet are to be interpreted as DQS_t, DQS_c and CK_t, CK_c respectively, unless specifically stated otherwise.
- Complete functionality may be described throughout the entire document; any page or diagram may have been simplified to convey a topic and may not be inclusive of all requirements.
- Any specific requirement takes precedence over a general statement.
- Any functionality not specifically stated here within is considered undefined, illegal, and not supported, and can result in unknown operation.
- Addressing is denoted as BG[n] for bank group, BA[n] for bank address, and A[n] for row/col address.
- A NOP is considered a valid command for very specific states such as power-down exit, self-refresh exit, and reset. The NOP must satisfy any associated command timings with respect to the preceding valid command.
- Not all features described within this document may be available on the Rev. A (first) version.
- Not all specifications listed are finalized industry standards; best conservative estimates have been provided when an industry standard has not been finalized.
- Although it is implied throughout the specification, the DRAM must be used after reaching a stable power-on level, which is achieved by following the proper voltage ramp and power-up initialization sequence procedures as outline in this specification.
- Not all features designated in the data sheet may be supported by earlier die revisions due to late definition by JEDEC.

Definitions of the Device-Pin Signal Level

- HIGH: A device pin is driving the logic 1 state.
- LOW: A device pin is driving the logic 0 state.
- High-Z or (HI-Z/Hi-Z): A device pin is tri-state
- ODT: A device pin terminates with the ODT settings, which could be terminating or tri-state depending on the mode register settings.

Definitions of the Bus Signal Level

- HIGH: One device on the bus is HIGH, and all other devices on the bus are either ODT or High-Z. The voltage level on the bus is nominally V_{DDQ} .
- LOW: One device on the bus is LOW, and all other devices on the bus are either ODT or High-Z. The voltage level on the bus is nominally $V_{OL(DC)}$ if ODT was enabled, or V_{SSQ} if High-Z.
- High-Z or (HI-Z/Hi-Z): All devices on the bus are High-Z. The voltage level on the bus is undefined as the bus is floating.

- ODT: At least one device on the bus is ODT, and all others are High-Z. The voltage level on the bus is nominally V_{DDQ} .
- The specification requires 8,192 refresh commands within 32ms between 0°C and 85°C. This allows for a t_{REFI} of 3.9 μ s in normal refresh mode. The specification also requires 8,192 refresh commands within 16ms between 85°C and 95°C. This allows for a t_{REFI} of 1.95 μ s in normal refresh mode.

Industrial Temperature

An industrial temperature (IT) device option requires that the case temperature not exceed below -40°C or above 95°C. JEDEC specifications require the refresh rate to double when T_C exceeds 85°C; this also requires use of the high-temperature self-refresh option. Additionally, ODT resistance and the input/output impedance must be derated when operating outside of the commercial temperature range, when T_C is between -40°C and 0°C.

Automotive Temperature

The automotive temperature (AT) device option requires that the case temperature not exceed below -40°C or above 105°C. The specifications require the refresh rate to 2X when T_C exceeds 85°C; 4X when T_C exceeds 95°C. Additionally, ODT resistance and the input/output impedance must be derated when operating temperature $T_c < 0^\circ\text{C}$.

Figure 2: 4 Gig x4 Functional Block Diagram

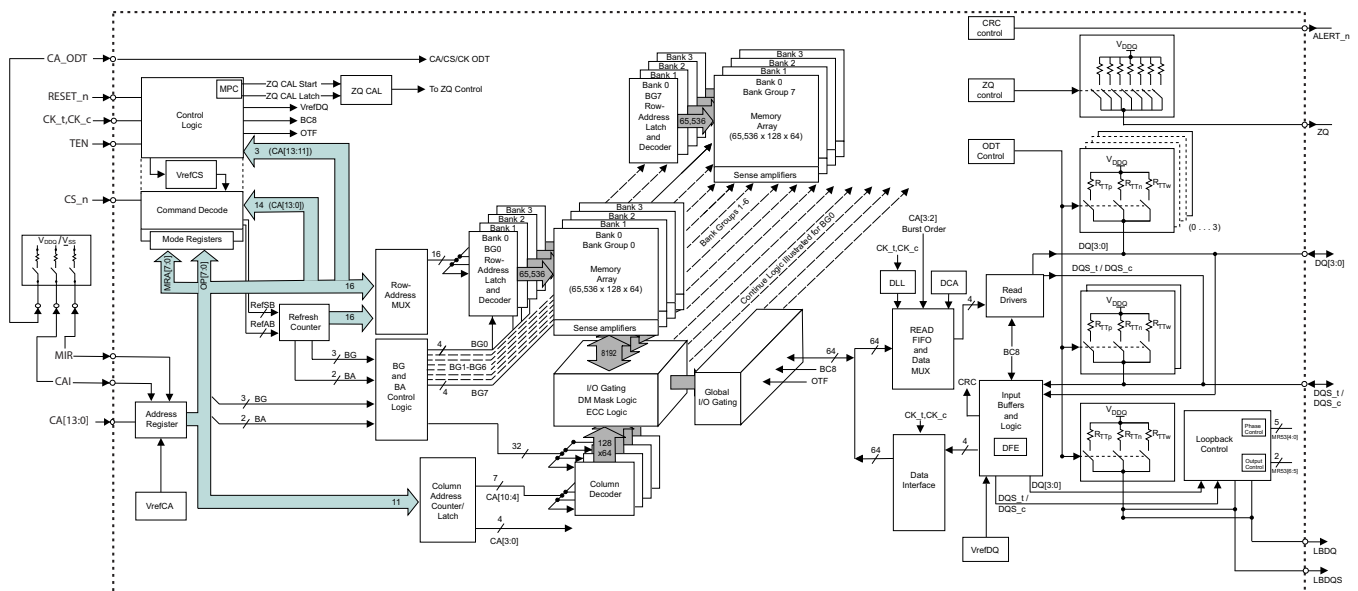

Figure 3: 2 Gig x8 Functional Block Diagram

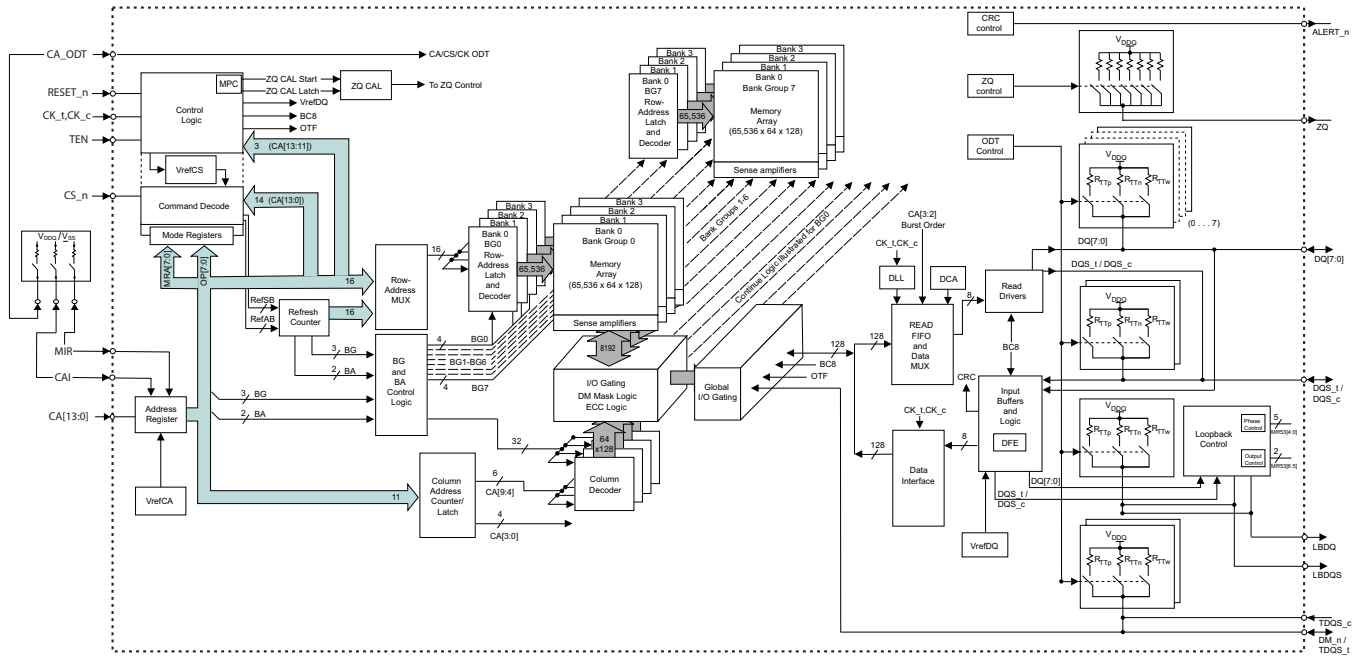
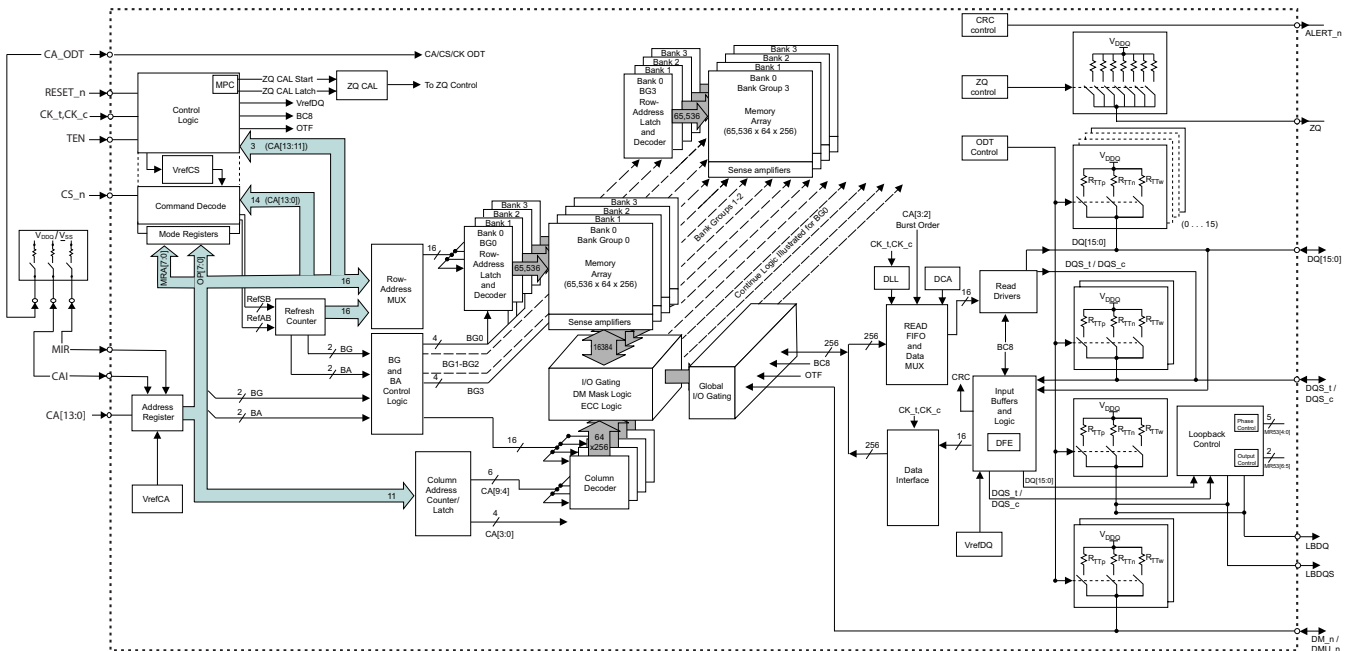

Figure 4: 1 Gig x16 Functional Block Diagram





DDR5 Function Matrix

DDR5 SDRAM has several features supported by configuration width, by density, by speed and by device die Rev. The following table is the summary of the features supported by 16Gb Die Revision A by configuration width. The functional matrix will be defined in each device-specific data sheet; therefore, device, speed and density options will vary by device data sheet.

Table 3: DDR5 Function Matrix - 16Gb Die Rev. A (by configuration width). V: Supported, Blank: Not Supported

Function	x4	x8	x16	MR Default State	Notes
BC8 OTF	V	V	V		
BL32 (JEDEC optional)					
BL32 OTF (JEDEC optional)					
TDQS		V			
Data Mask (DM)		V	V		
Data Output Disable	V	V	V		
Connectivity Test Mode (CT)	V	V	V		
CA/CS/CK ODT	V	V	V		
2N Mode	V	V	V		5
Per DRAM Addressability (Enum)	V	V	V		
Mode Register Read (MRR)	V	V	V		3
Mode Register Write (MRW)	V	V	V		
Multi-Purpose Command (MPC)	V	V	V		
ZQ calibration	V	V	V		
CA Vref Training	V	V	V		1
CS Vref Training	V	V	V		2
DQ Vref Training	V	V	V		
CS Training Mode (CSTM)	V	V	V		
CA Training Mode (CATM)	V	V	V		
Write Leveling Training	V	V	V		
WICA 1/2 step, a feature add for Internal WL (JEDEC Optional)	V	V	V		
Read Training Pattern Mode (LFSR)	V	V	V		
Write Pattern Command	V	V	V		
DQS Interval Oscillator	V	V	V		
Duty Cycle Adjuster (DCA)	V	V	V	MR42:OP[1:0] = 01	10
Loopback Mode	V	V	V		
Decision Feedback Equalization (DFE)	V	V	V		
Maximum Power Saving Mode (MPSM)	V	V	V		6
Package Output Driver Test mode (PODTM)	V	V	V		
PASR (JEDEC Optional)				MR19:OP[7] = 0	11
WRITE CRC	V	V	V		



Table 3: DDR5 Function Matrix - 16Gb Die Rev. A (by configuration width). V: Supported, Blank: Not Supported (Continued)

Function	x4	x8	x16	MR Default State	Notes
READ CRC	V	V	V		4
Programmable Preamble	V	V	V		
Programmable Postamble	V	V	V		
sPPR	V	V	V		
hPPR	V	V	V		
MBIST/mPPR (JEDEC optional)				MR23:OP[4:3] = 00	12
PPR using DQ[3:0] only	V	V	V		
sPPR undo/lock (JEDEC optional)	V	V	V	MR23:OP[2] = 1	13
On-Die-ECC	V	V	V		
ECC Transparency and Error Scrub	V	V	V		
H-Matrix Revision supporting bounded fault self-aliasing	V	V	V		
Same Bank Refresh	V	V	V		7
Same Bank Precharge	V	V	V		
Refresh Management (RFM)	V	V	V	MR58:OP[0] = 0	9
				MR58:OP[7:5] = 110	14
				MR58:OP[4:1] = 1010	
				MR59:OP[7:6] = 00	
Adaptive RFM (JEDEC Optional)					
Directed RFM (JEDEC Optional)					
Fine Granularity Refresh (FGR)	V	V	V		
Refresh Interval Rate (RIR) (JEDEC Optional)				MR4:OP[3] = 0	15
Wide Temperature Range (JEDEC Optional)				MR4:OP[5] = 0	16
Test Mode MR (MR9)					8
ECS Writeback Suppression (JEDEC Optional)	V	V	V		
x4 RMW Suppression (JEDEC Optional)	V				

- Notes: 1. CA Vref Training was added to support internally generated CA Vref.
 2. CS Vref Training was added to support internally generated CS Vref.
 3. Mode Register Read (MRR) is similar to DDR4's MPR.
 4. Read CRC as well as Write CRC are supported on DDR5.
 5. 2N Mode replaced what was called Gear Down Mode on DDR4.
 6. MPSM has three states defined: idle, power down and deep power down.
 7. Same Bank Refresh requires FGR be enabled.
 8. Test Mode (TM) is a vendor-specific mode register; not used by Micron.
 9. RFM not required.
 10. Device supports DCA for single/two-phase internal clock(s).
 11. PASR not supported.
 12. MBIST/mPPR not supported.
 13. sPPR lock/undo supported.
 14. RAAMMT, RAAIMT, and RAA counter decrement are only applicable if the RFM requirement bit is set to 1 (MR58:OP[0]=1).



- 15. RIR indicator not implemented.
- 16. Wide temperature range not supported.

DDR5 Package Pinout and Assignments

Rows

The x4/x8 device has 13 electrical rows of balls. The x16 device has 17 electrical rows of balls. Electrical is defined as rows that contain signal ball or power/ground balls. Additional rows of inactive balls may be available for mechanical support.

Ball Pitch

The device uses a ball pitch of 0.8mm x 0.8mm.

Columns

The number of depopulated columns is 3.

The device has six electrical columns of balls in two sets of three columns. Between the electrical columns are three columns where no balls are populated. Electrical is defined as columns that contain signal ball or power/ground balls. Additional columns of inactive balls may be available for mechanical support.

Figure 5: x4/x8 Ballout Using MO-210-AN – 82-Ball

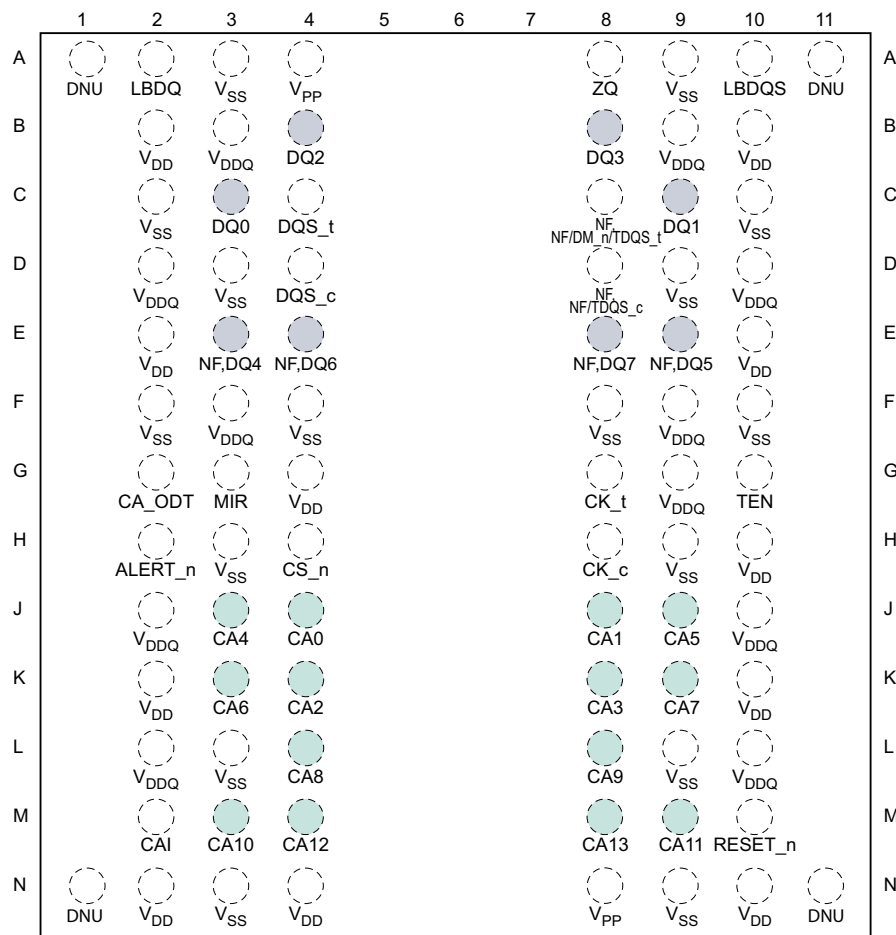

- Notes:
1. Additional columns and rows of inactive balls in MO-210-AN terminal pattern (x4/x8) with support balls are for mechanical support only and should not be tied electrically high or low.
 2. Some of the additional support balls can be selectively populated at the suppliers' discretion.
 3. DQ4-DQ7 higher-order DQ pins are connected but not used in the x4 configuration.
 4. DM, TDQS_t and TDQS_c are not valid for the x4 configuration.
 5. A comma "," separates the configuration. A slash "/" defines a mode register-selectable function, command/address function, density or package dependence.

Figure 6: x16 Ballout Using MO-210-AT –102 Ball

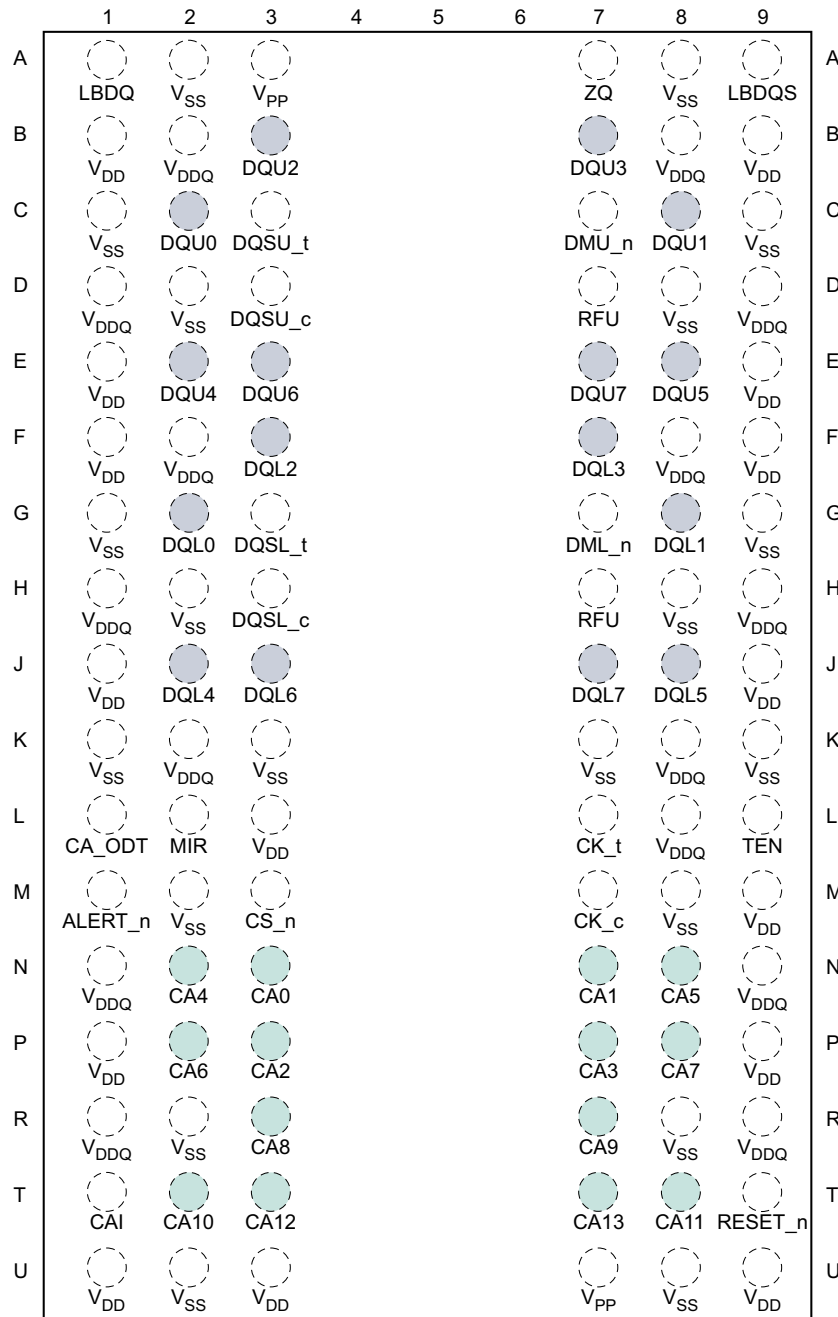

- Notes: 1. Additional columns and rows of inactive balls in MO-210-AU terminal pattern (x16) with support balls are for mechanical support only and should not be tied electrically high or low.
 2. Some of the additional support balls can be selectively populated at the suppliers' discretion.

Table 4: Pinout Description

Symbol	Type	Function
CK_t, CK_c	Input	Clock: CK_t and CK_c are differential clock inputs. All command/address and control input signals are sampled on the crossing of the positive edge of CK_t and negative edge of CK_c.
CS_n	Input	Chip Select: All commands are masked when CS_n is registered HIGH. CS_n provides for external rank selection on systems with multiple ranks. CS_n is considered part of the command code and is used to enter and exit the parts from power down mode and self refresh mode. While not in self refresh mode, the CS_n input buffer operates with the same ODT and V _{REF} parameters as configured by the CA_ODT strap setting or mode register. When in self refresh mode, the CS_n is a CMOS rail-to-rail signal with DC HIGH and LOW at 80% and 20% of V _{DDQ} .
DM_n, DMU_n, DML_n	Input	Input Data Mask: DM_n is an input mask signal for write data. Input data is masked when DM_n is sampled LOW coincident with that input data during a write access. DM_n is sampled on both edges of DQS. DM_n is not supported on x4 devices. For x8 devices, the function of DM_n is enabled by the mode register. For x16 devices, the function of DMU_n/DML_n is enabled by the mode register.
CA[13:0]	Input	Command/Address Inputs: Command/Address (CA) signals provide the command and address inputs according to the Command Truth Table. Because some commands are multicycle, the pins may not be interchanged between devices on the same bus.
RESET_n	Input	Active Low Asynchronous Reset: Reset is active when RESET_n is LOW, and inactive when RESET_n is HIGH. RESET_n must be HIGH during normal operation. RESET_n is a CMOS rail-to-rail signal with DC HIGH and LOW at 80% and 20% of V _{DDQ} .
DQ	Input/Output	Data Input/Output: Bidirectional data bus. If CRC is enabled via the mode register, CRC code is added at the end of a data burst.
DQS_t, DQS_c, DQSU_t, DQSU_c, DQSL_t, DQSL_c	Input/Output	Data Strobe: Output with read data, input with write data, edge-aligned with read data, centered in write data. For x16 devices, DQSL corresponds to the data on DQL0-DQL7; DQSU corresponds to the data on DQU0-DQU7. The data strobes DQS_t, DQSL_t and DQSU_t are paired with differential signals DQS_c, DQSL_c, and DQSU_c, respectively, to provide differential pair signaling to the system during reads and writes. The device supports differential data strobe only, not single-ended.
TDQS_t, TDQS_c	Output	Termination Data Strobe: Applicable to x8 devices only. When enabled via the mode register, the device enables the same termination resistance function on TDQS_t/TDQS_c that is applied to DQS_t/DQS_c. When disabled via the mode register, DM/TDQS provides the data mask function depending on the MR setting; TDQS_c is not used. x4/x16 devices must disable the TDQS function via the mode register.
ALERT_n	Input/Output	Alert: If there is an error in CRC, ALERT_n drives LOW for the period time interval and returns HIGH. During the connectivity test mode, this pin functions as an input. Usage of this signal is system-dependent. In cases where this pin is not connected, ALERT_n must be bonded to V _{DDQ} on the system board.
TEN	Input	Connectivity Test Mode Enable: A HIGH on this pin enables CONNECTIVITY TEST MODE operation along with other pins. It is a CMOS rail-to-rail signal with AC HIGH and LOW at 80% and 20% of V _{DDQ} . Usage of this signal is system-dependent. This pin is pulled LOW internally with a weak pulldown resistor to V _{SS} .

Table 4: Pinout Description (Continued)

Symbol	Type	Function
MIR	Input	Mirror: Used to inform the system that this device is being run in mirrored mode instead of standard mode. With the MIR pin connected (strapped) to V_{DDQ} , the device internally swaps even-numbered CA with the next higher odd-number CA. The MIR pin must be tied to V_{SS} if no CA mirror is required. Mirror pair examples: CA2 with CA3 (not CA1) CA4 with CA5 (not CA3). Note: the CA[13] function is only relevant for certain densities (including stacking). In the case that CA[13] is not used, its ball location, considering whether MIR is used or not, should be connected (strapped) to V_{DDQ} . No active signaling requirements required.
CAI	Input	Command and Address Inversion: With this pin connected (strapped) to V_{DDQ} , the device internally inverts the logic level present on all CA signals. The CAI pin must be connected to V_{SS} if no CA inversion is required. No active signaling requirements required.
CA_ODT	Input	ODT for Command and Address: Apply Group A settings if the pin is connected (strapped) to V_{SS} ; apply Group B settings if the pin is connected (strapped) to V_{DDQ} . See the mode register defaults table for details. No active signaling requirements required.
LBDQ	Output	Loopback Data Output: The output of this device on the Loopback Output Select defined in MR53:OP[4:0]. When loopback is enabled, it is in driver mode using the default RON described in the Loopback Function section. When loopback is disabled, the pin is either terminated or High-Z based on MR36:OP[2:0].
LBDQS	Output	Loopback Data Strobe Output: A single-ended strobe with the rising edge aligned with loopback data edge, falling edge aligned with data center. When loopback is enabled, it is in driver mode using the default RON described in the Loopback function section. When loopback is disabled, the pin is either terminated or High-Z based on MR36:OP[2:0].
RFU	Input/Output	Reserved for future use.
DNU		Do not use.
NF		No function: Internal connection is present but has no function.
V_{DDQ}	Supply	DQ power supply; 1.1V nominal.
V_{DD}	Supply	Power supply; 1.1V nominal.
V_{SS}	Supply	Ground
V_{PP}	Supply	Activating power supply; 1.8V nominal.
ZQ	Reference	Reference pin for ZQ calibration. This ball is tied to an external 240 ohm resistor (RZQ), which is tied to V_{SS} .

Package Dimensions

Figure 7: 82-Ball VFBGA – MO-210-AN (x4/x8)

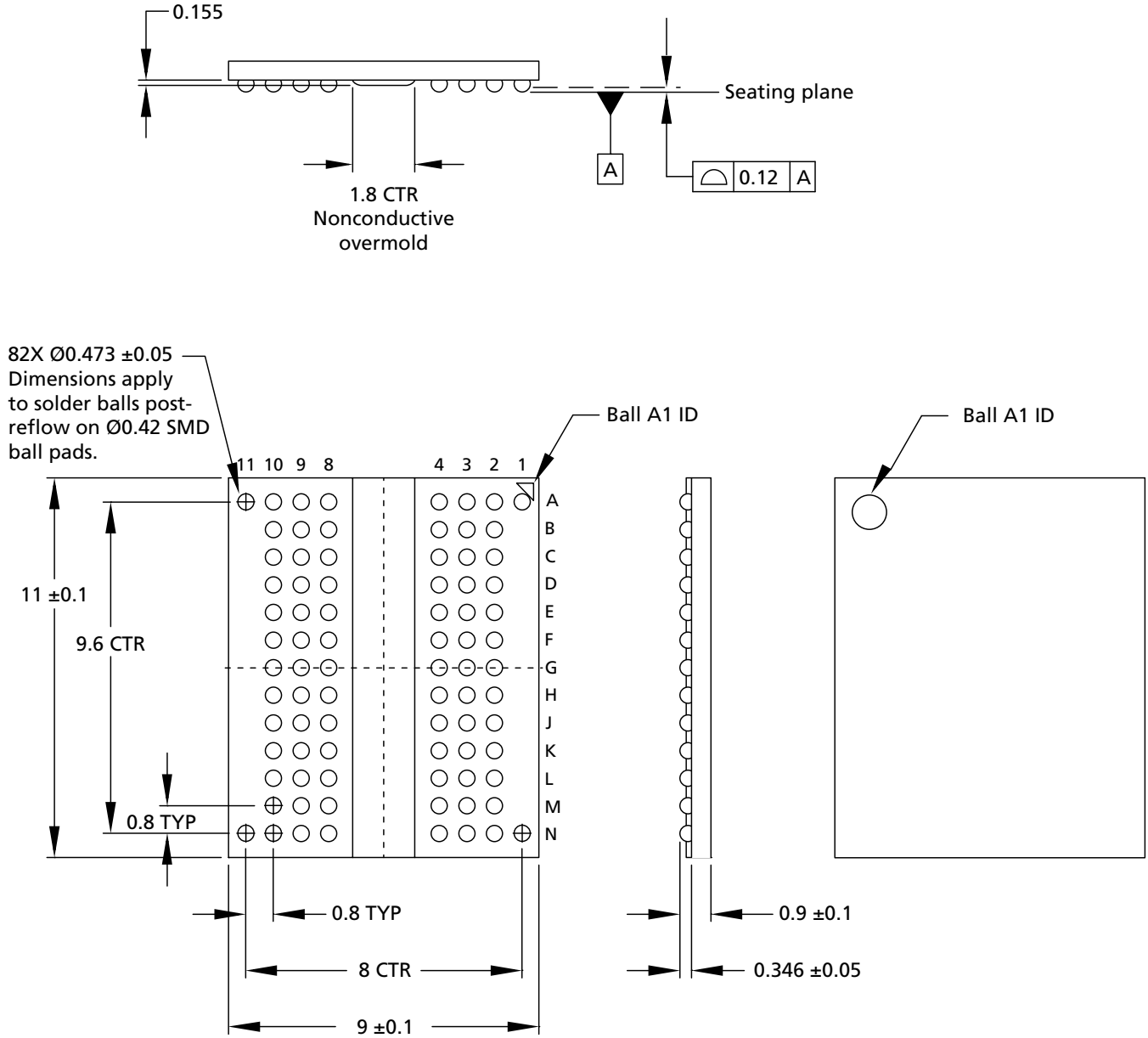

- Notes: 1. All dimensions are in millimeters.
2. Solder ball material: SAC305 (96.5% Sn, 3% Ag, 0.5% Cu).

Figure 8: 102-Ball VFBGA – MO-210-AT (x16)

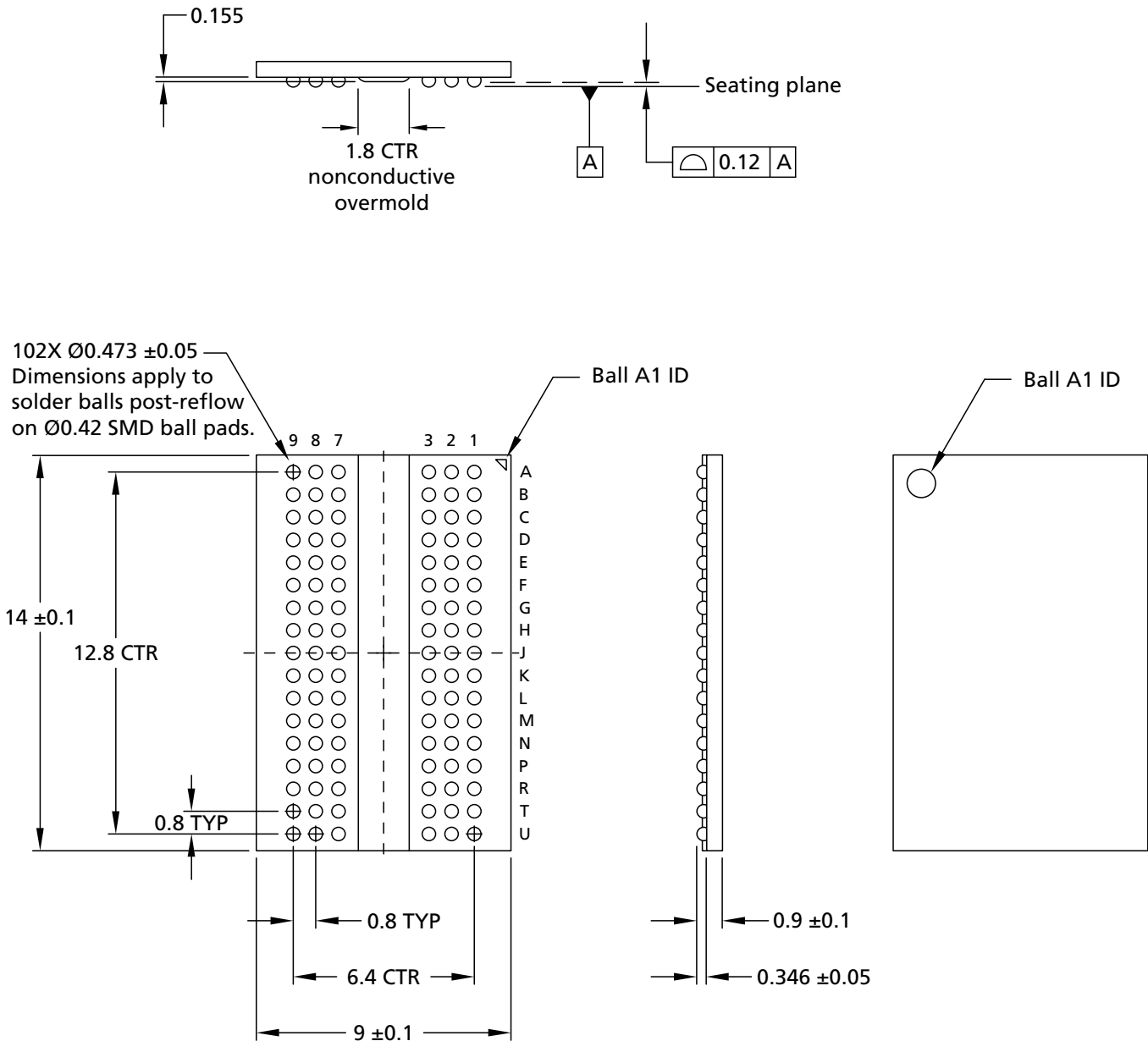

- Notes: 1. All dimensions are in millimeters.
2. Solder ball material: SAC305 (96.5% Sn, 3% Ag, 0.5% Cu).

Table 5: Package Thermal Resistance Characteristics

Die Revision	Package	Parameter	Value	Unit	Symbol
Rev A	82-ball "HB"	Junction-to-case (TOP)	2.6	°C/W	θJC
		Junction-to-board	12.8	°C/W	θJB
	102-ball "HC"	Junction-to-case (TOP)	2.6	°C/W	θJC
		Junction-to-board	12.8	°C/W	θJB



DDR5 IDD,IPP,IDDQ Current Limits

DDR5 SDRAM current limits are measured and categorized based on the definitions found in the DDR5 Product Core data sheet. Refer to the IDD and IDDQ specification parameters and test conditions for details related to each current limit. Notes 1 and 2 apply to entire table

Table 6: DDR5 IDD, IPP, IDDQ Current Limits – 16Gb Die Revision A

Parameter	Width	DDR5-4800	Unit	Notes
IDD0	x4	103	mA	
	x8			
	x16	122		
IPP0	x4	8	mA	
	x8			
	x16	10		
IDDQ0	x4	31	mA	
	x8			
	x16			
IDD0F	x4	142	mA	
	x8			
	x16	164		
IPP0F	x4	10	mA	
	x8			
	x16	13		
IDDQ0F	x4	33	mA	
	x8			
	x16			
IDD2N	x4	92	mA	
	x8			
	x16			
IPP2N	x4	6	mA	
	x8			
	x16			
IDDQ2N	x4	33	mA	
	x8			
	x16			
IDD2NT	x4	149	mA	
	x8			
	x16			



**16Gb DDR5 SDRAM Die Rev A
DDR5 IDD,IPP,IDDQ Current Limits**

Table 6: DDR5 IDD, IPP, IDDQ Current Limits – 16Gb Die Revision A

Parameter	Width	DDR5-4800	Unit	Notes
IPP2NT	x4	6	mA	
	x8			
	x16			
IDDQ2NT	x4	32	mA	
	x8			
	x16			
IDD2P	x4	88	mA	
	x8			
	x16			
IPP2P	x4	6	mA	
	x8			
	x16			
IDDQ2P	x4	24	mA	
	x8			
	x16			
IDD3N	x4	142	mA	
	x8			
	x16			
IPP3N	x4	7	mA	
	x8			
	x16			
IDDQ3N	x4	31	mA	
	x8			
	x16			
IDD3P	x4	140	mA	
	x8			
	x16			
IPP3P	x4	7	mA	
	x8			
	x16			
IDDQ3P	x4	24	mA	
	x8			
	x16			
IDD4R	x4	318	mA	
	x8	377		
	x16	530		



Table 6: DDR5 IDD, IPP, IDDQ Current Limits – 16Gb Die Revision A

Parameter	Width	DDR5-4800	Unit	Notes
IPP4R	x4	9	mA	
	x8			
	x16			
IDDQ4R	x4	43	mA	
	x8	57		
	x16	92		
IDD4RC	x4	328	mA	
	x8	389		
	x16	546		
IPP4RC	x4	9	mA	
	x8			
	x16			
IDDQ4RC	x4	44	mA	
	x8	57		
	x16	93		
IDD4W	x4	345	mA	
	x8	349		
	x16	479		
IPP4W	x4	36	mA	
	x8	37		
	x16	64		
IDDQ4W	x4	116	mA	
	x8	198		
	x16	348		
IDD4WC	x4	311	mA	
	x8	316		
	x16	421		
IPP4WC	x4	35	mA	
	x8	37		
	x16	64		
IDDQ4WC	x4	116	mA	
	x8	194		
	x16	344		
IDD5B	x4	277	mA	
	x8			
	x16			



Table 6: DDR5 IDD, IPP, IDDQ Current Limits – 16Gb Die Revision A

Parameter	Width	DDR5-4800	Unit	Notes
IPP5B	x4	28	mA	
	x8			
	x16			
IDDQ5B	x4	32	mA	
	x8			
	x16			
IDD5C	x4	135	mA	
	x8			
	x16			
IPP5C	x4	12	mA	
	x8			
	x16			
IDDQ5C	x4	32	mA	
	x8			
	x16			
IDD5F	x4	262	mA	
	x8			
	x16			
IPP5F	x4	26	mA	
	x8			
	x16			
IDDQ5F	x4	32	mA	
	x8			
	x16			
IDD6N(0-85C)	x4	102	mA	3,4
	x8			
	x16			
IPP6N (0-85C)	x4	15	mA	3,4
	x8			
	x16			
IDDQ6N (0-85C)	x4	16	mA	3,4
	x8			
	x16			
IDD6E (85-95C)	x4	200	mA	4,5
	x8			
	x16			



Table 6: DDR5 IDD, IPP, IDDQ Current Limits – 16Gb Die Revision A

Parameter	Width	DDR5-4800	Unit	Notes
IPP6E (85-95C)	x4	25	mA	4,5
	x8			
	x16			
IDDQ6E (85-95C)	x4	19	mA	4,5
	x8			
	x16			
IDD7	x4	448	mA	
	x8	502		
	x16	775		
IPP7	x4	23	mA	
	x8	23		
	x16	35		
IDDQ7	x4	50	mA	
	x8	64		
	x16	100		
IDD8	x4	80	mA	
	x8			
	x16			
IPP8	x4	6	mA	
	x8			
	x16			
IDDQ8	x4	19	mA	
	x8			
	x16			

- Notes: 1. Some I_{DD} currents are higher for x16 organization due to larger page-size architecture.
 2. Maximum values for I_{DD} currents considering worst-case conditions of process, temperature, and voltage.
 3. Applicable for MR4:OP[2:0]=001b, 010b.
 4. Supplier data sheets include a maximum value for I_{DD6} .
 5. Applicable for MR4:OP[2:0]=011b, 100b, 101b.



Revision History

Rev. D – 02/2023

- Functional block diagrams updated

Rev. C – 01/2023

- Removed 52B, 56B speed bins (not supported in 16Gb Die Revision A).
- Added functional block diagrams.
- Moved thermal characteristics table under package dimension topic.

Rev. B – 10/2021

- Removed Micron Confidential marking.
- Updated DDR5 Function Matrix table to add default mode register states.

Rev. A – 09/2021

- Initial release

8000 S. Federal Way, P.O. Box 6, Boise, ID 83707-0006
208-368-4000, micron.com/support

Micron and the Micron logo are trademarks of Micron Technology, Inc.
All other trademarks are the property of their respective owners.

This data sheet contains minimum and maximum limits specified over the power supply and temperature range set forth herein. Although considered final, these specifications are subject to change, as further product development and data characterization sometimes occur.