

Attracting Tomorrow

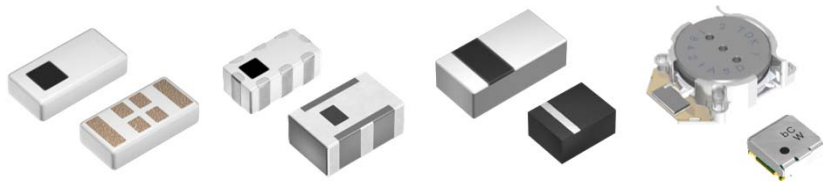

# RF COMPONENTS

## TDK DEVELOPERS CONFERENCE 2018



**TDK Corporation of America** | A TDK Group Company  
Communication Devices Business Group • Product Marketing Department  
Santa Clara, CA, USA • September 17 - 18, 2018

# Agenda

---

- Intro to RF Components & Applications
- PCB Layout Design Case Studies for RF Components
- Chip Antenna Design Guideline & Technical Support
- TDK RF Product Center Website Walkthrough
- TDK RF Product Line Summary
- TDK RF Design Support & Technical Tools

Attracting Tomorrow



# RF Components & Applications Introduction

---



**TDK OFFERS COMPLETE FRONT-END SOLUTION FOR WIRELESS SYSTEM DESIGN**



# TDK RF Material Technology

## LTCC TECHNOLOGY

For over 25 years, TDK has been instrumental in the development of RF technologies. TDK's industry leading RF components are based on the same Low Temperature Co-fired Ceramic (LTCC) technology used in our multilayer ceramic capacitors and multilayer inductors. More than ten layers (up to 35 layers) are stacked to integrate passive circuit elements using LTCC process.

### Design Advantages

- High dielectric constant ceramic materials enables down-sizing of component
- Allows co-firing of two or more different dielectric materials for improved performance
- High-Q, low cost and shorter lead-time

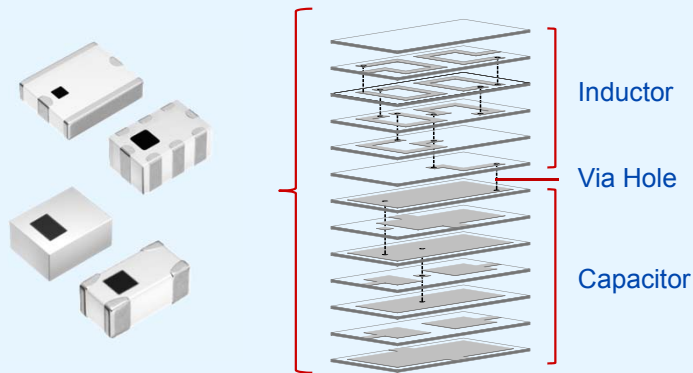

## THIN FILM

Originally, TDK developed the Thin-film process technology for HDD R/W heads. TDK now brings this leading-edge technology to RF components. This enables us to develop compact, low-profile components with outstanding performance ideally suited for applications such as smart phones. Thin film process provides fine pattern, high precision, and miniaturization for RF components.

### Design Advantages

- Ferrite materials enables high quality factor
- Non-magnetic ferrite carrier with thin-film process enable world's smallest RF components
- Small variation in performance and smaller/thinner component with same performance (space saving)

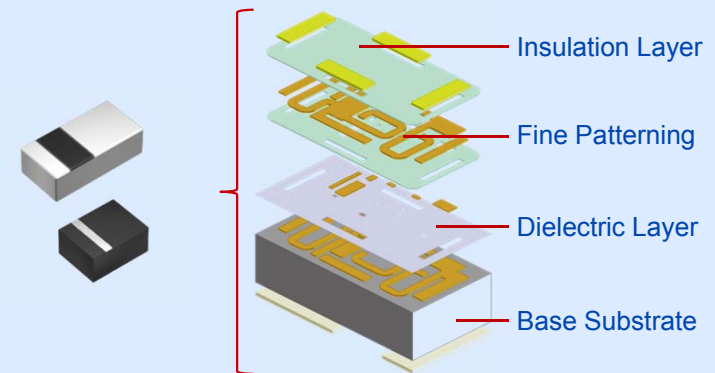

# ■ TDK RF Component Lineup

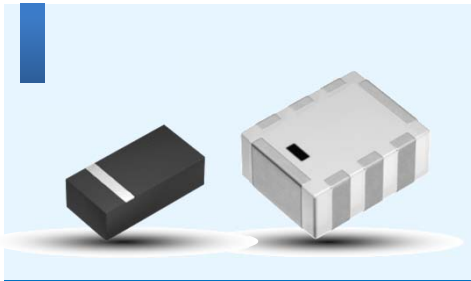

## | Filters (BPF / LPF /HPF)

TDK's DEA and TFS series filters are designed using Low Temperature Co-fired Ceramic (LTCC) or Thin Film technology and create a resonance frequency allowing certain frequency ranges to pass while blocking, or attenuating, other unwanted frequency ranges. TDK offers both high and low pass filters, as well as band pass filters with frequencies ranging from 5MHz to 8GHz with variation in shape and size, terminal structure, specification values, etc.

TDK filters are used in products with a wide variety of wireless communications such as WLAN, BT, cellular, GPS, ZigBee, WiMAX and in both licensed and unlicensed frequencies.

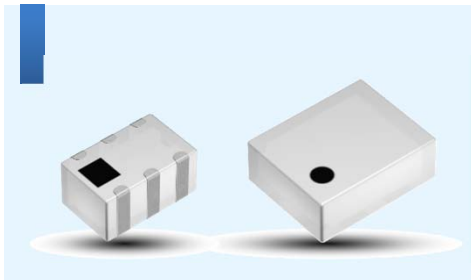

## | Diplexers

TDK's DPX series diplexers are 3-port filters that divide/route two frequencies from a common port. These diplexers offer low insertion loss and high attenuation versions and are available in various combinations of LPF/BPF/HPF designs. With dimensions ranging from 1.0 × 0.5mm to 2.5 × 2.0mm, their compact size and high performance offers stable characteristics for applications including 2.4GHz & 5GHz Wi-Fi, Bluetooth, ZigBee, LTE and GPS.

TDK diplexers using Low Temperature Co-fired Ceramic (LTCC) are available in a wide product range with variations in frequency, size, terminal structure, specification values, etc.

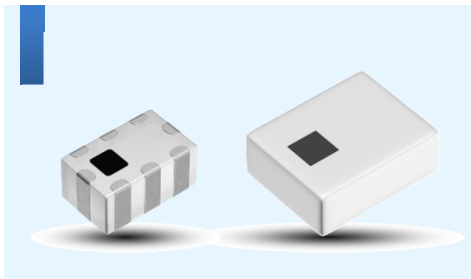

## | Triplexers

The newest of the filtering family, TPX series triplexers are designed to support high functionality with low insertion loss and high attenuation all in a compact 8 terminal SMD package measuring 2.0 × 1.25 x 0.9mm.

TDK triplexers are used in the I/O part of the antenna and have functions to separate or combine three different frequency signals during transmission and reception. They are also used in CA (carrier aggregation) circuits. The TPX series is designed for applications using a combination of GPS/Dual-band Wi-Fi/Bluetooth/ZigBee for connectivity. Look for new TPX products to support additional band combinations.

# ■ TDK RF Component Lineup

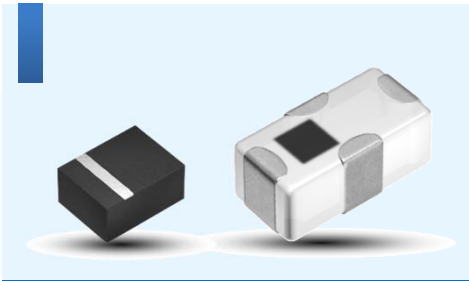

## | Baluns

A balun (balanced/unbalanced) is two port device use to connect a differential, balanced RF signal to a single-ended, unbalanced signal or vice versa. This device is essential in the RF signal chain because RFIC designs often use differential configurations for their internal topology since this provides improved noise immunity and better overall RF performance as well as lower cost. They are ideal for use in WLAN, Bluetooth, LTE, and GSM applications.

TDK's HHM1 and TFS Series baluns are available in a wide range of configurations with frequencies ranging from 673MHz to 5.95GHz and dimensions ranging from 0.65 × 0.5mm to 2.0 × 1.25mm.

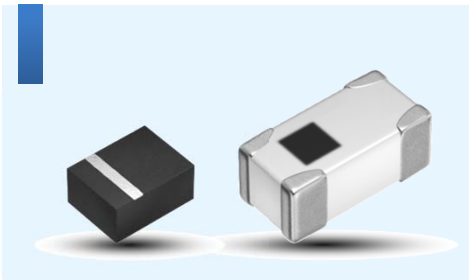

## | Couplers

Directional couplers are used for signal monitoring and signal reporting, e.g. frequency, power level, etc., without interrupting the main system power path. TDK's couplers utilize a Low Temperature Co-fired Ceramic (LTCC) process enabling low insertion loss and high isolation in small and compact package.

They are ideal for use in MIMO and CA designs for signal monitoring and controlling. Applications include WLAN, LTE, GSM and other applications where signal monitoring is required, e.g. to minimize battery consumption. 3dB Wilkinson power divider and power combiner as well as 2-in-1 coupler + LPF also available.

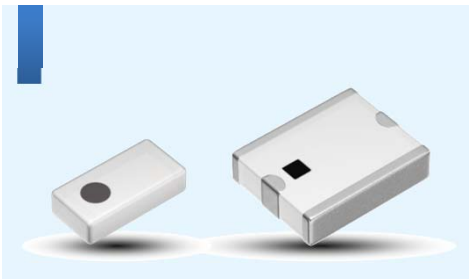

## | Chip Antennas

Antenna has the function to send and receive signals in the desired frequencies. TDK's ANT series ceramic chip antennas feature compact and low profile designs, with case sizes available as small as 1.6 × 0.8mm at a thickness of just 0.4mm. Even with their small size and thin profile, TDK antennas maintain high performance and reliability, all with the industry's smallest "keep-out" area on the PCB.

TDK antennas are capable of supporting multi-band applications including connectivity to mobile devices such as smartphones, tablets, wearables, IoT devices, smart meters, smart grids, HEMS, STBs, streaming devices, and game controllers.

# ■ Connectivity Applications

## INDUSTRIAL / M2M

Industry 4.0, factory automation, etc.



## HOME APPLIANCE

Smart Appliances, Smart TV, etc.



Game systems, Streaming Stick, STB, Wireless Speakers, Routers, Drones, Wearable, Hearable, etc.

## CONSUMER ELECTRONIC / INTERNET OF THINGS

# Connectivity Applications

**BLOCK DIAGRAM EXAMPLE  
DUAL WiFi w/ BLUETOOTH & GPS**

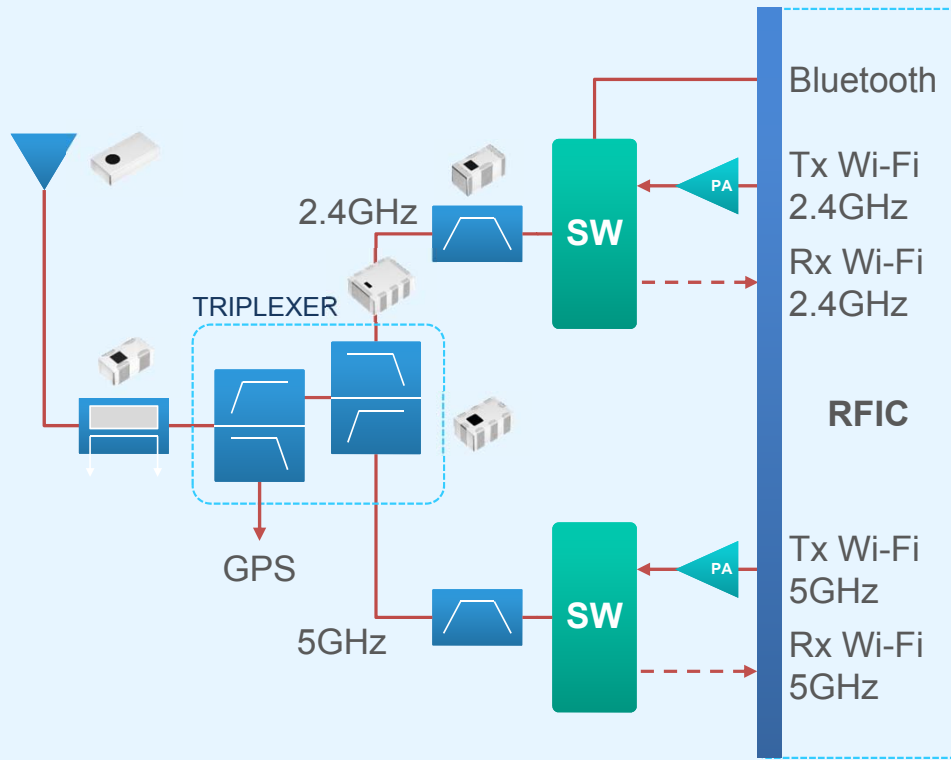

**BLOCK DIAGRAM EXAMPLE  
BLUETOOTH / ZIGBEE 2.4GHz**

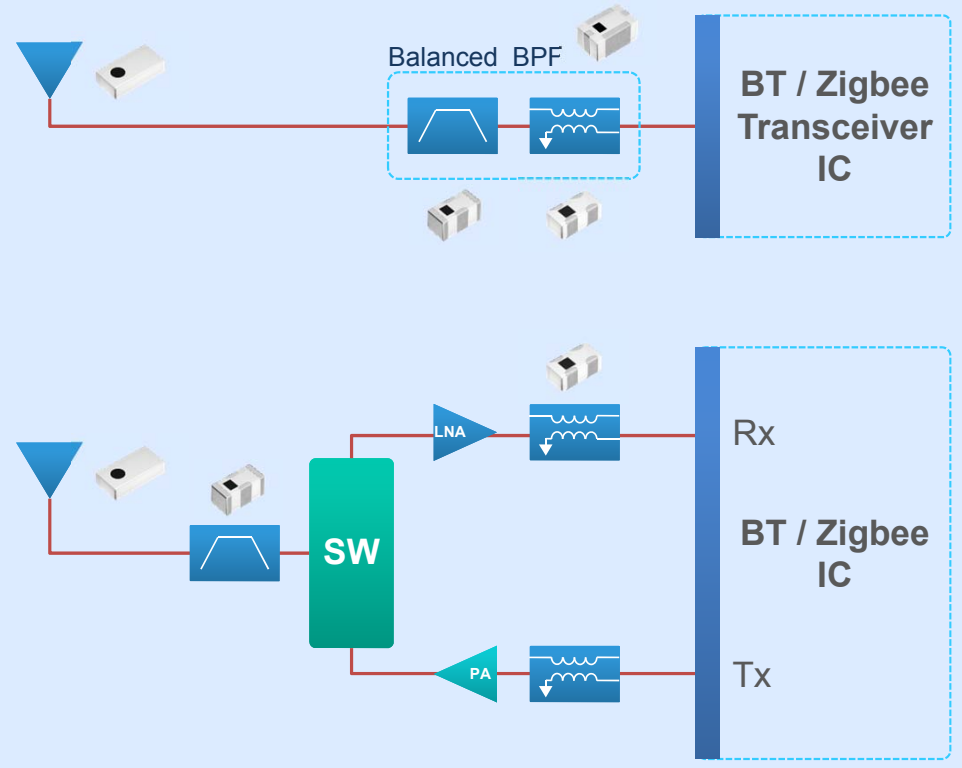

 Antenna  
  Balun  
  Diplexer  
  BPF  
  Power Amplifier  
  Low Noise Amplifier  
  Switch

# Cellular Applications

## SMART PHONE / TABLET

3G, LTE, Mobile Network Connected Devices, etc.



## INFRASTRUCTURE

Microcells, BTS, Small Cell, Repeaters, Security Cameras, etc.



Hotspot, Cell coverage booster, etc.

## MOBILE HOTSPOT / CELLULAR MODULES / OTHERS

# Cellular Applications

## BLOCK DIAGRAM EXAMPLE LTE w/ UHB and LTE-U/LAA

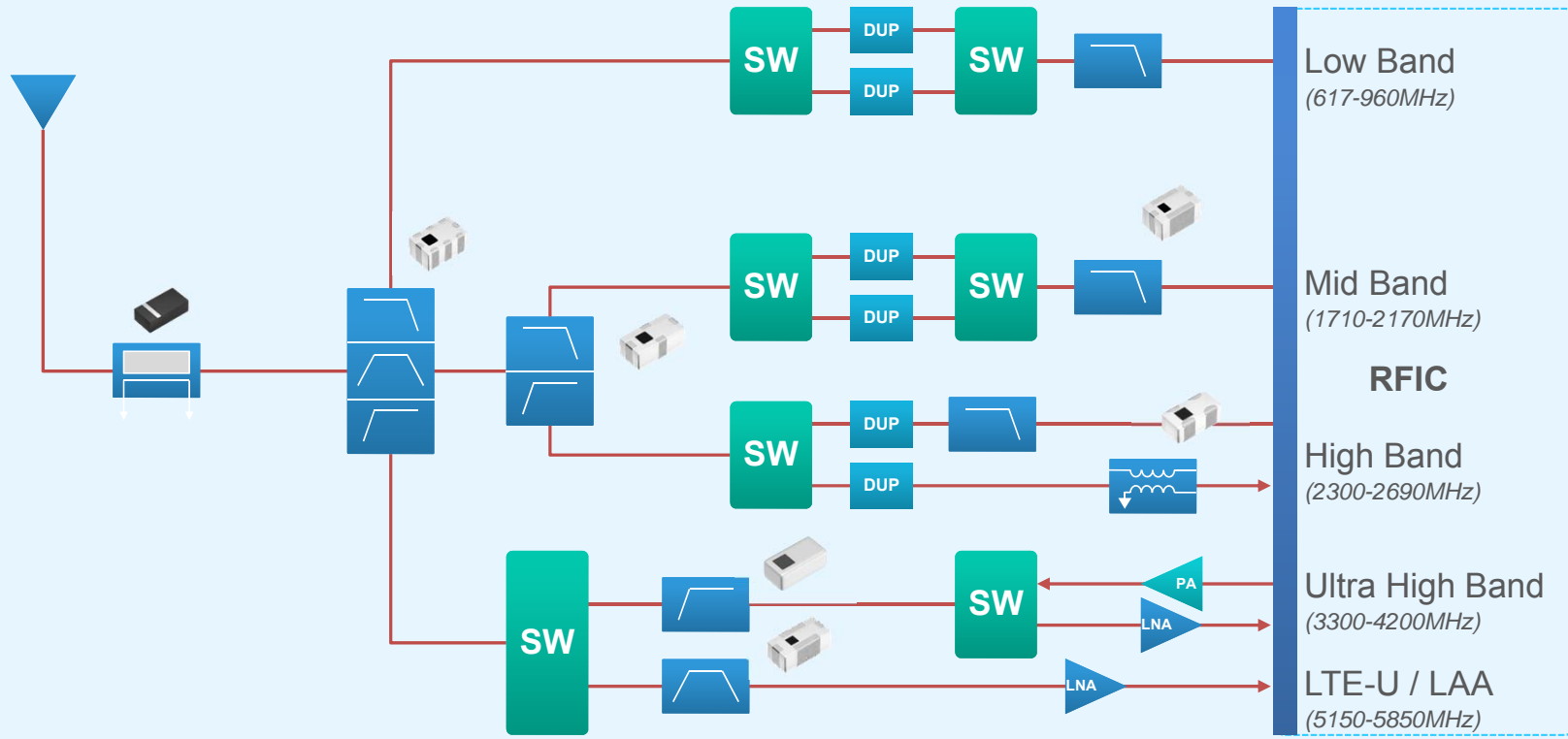

# Cellular Applications

## BLOCK DIAGRAM EXAMPLE BASE TRANSCEIVER STATION (BTS)

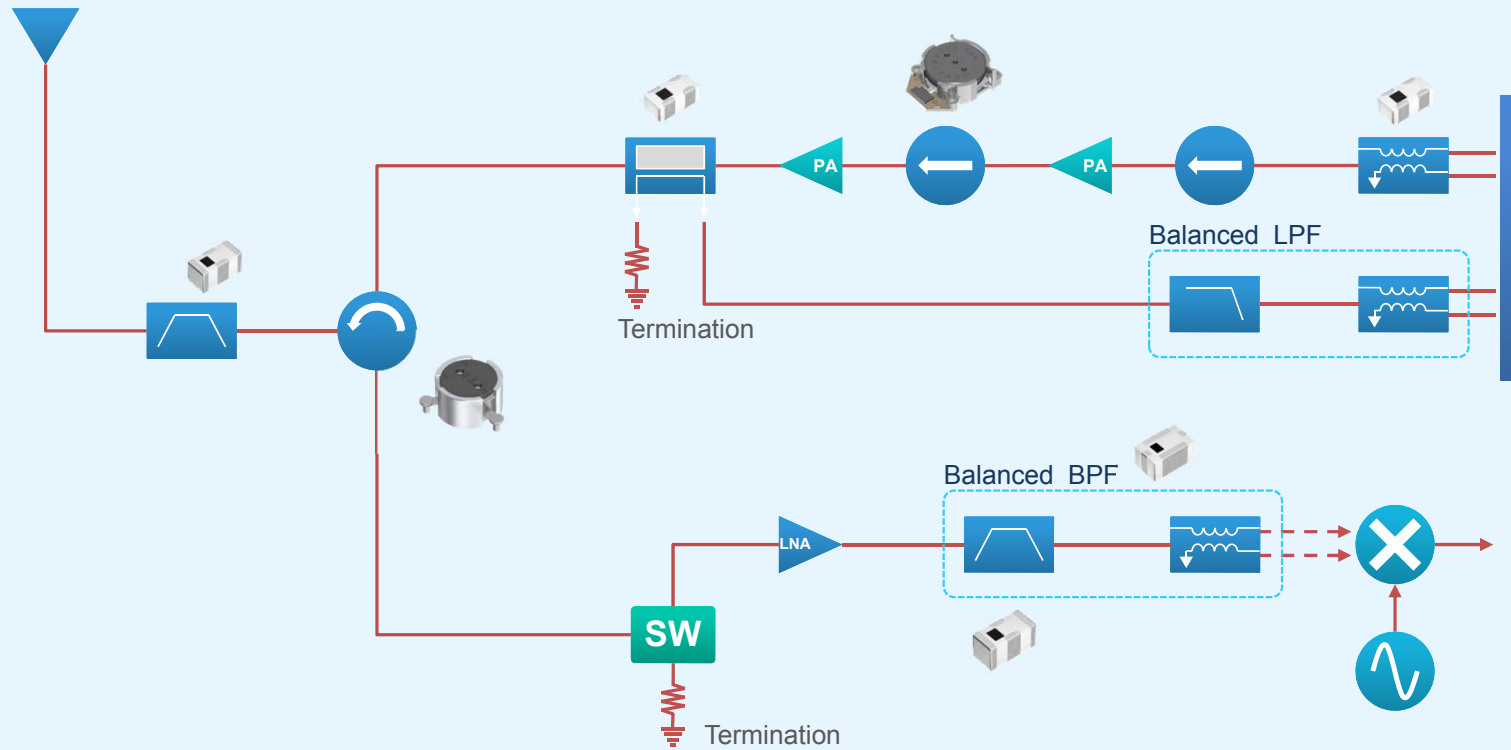

-  Antenna
-  BPF
-  LPF
-  Balun
-  SW Switch
-  Power Amplifier
-  Low Noise Amplifier
-  Circulator
-  Isolator
-  Mixer
-  Local Oscillator

# Cellular Technology Roadmap

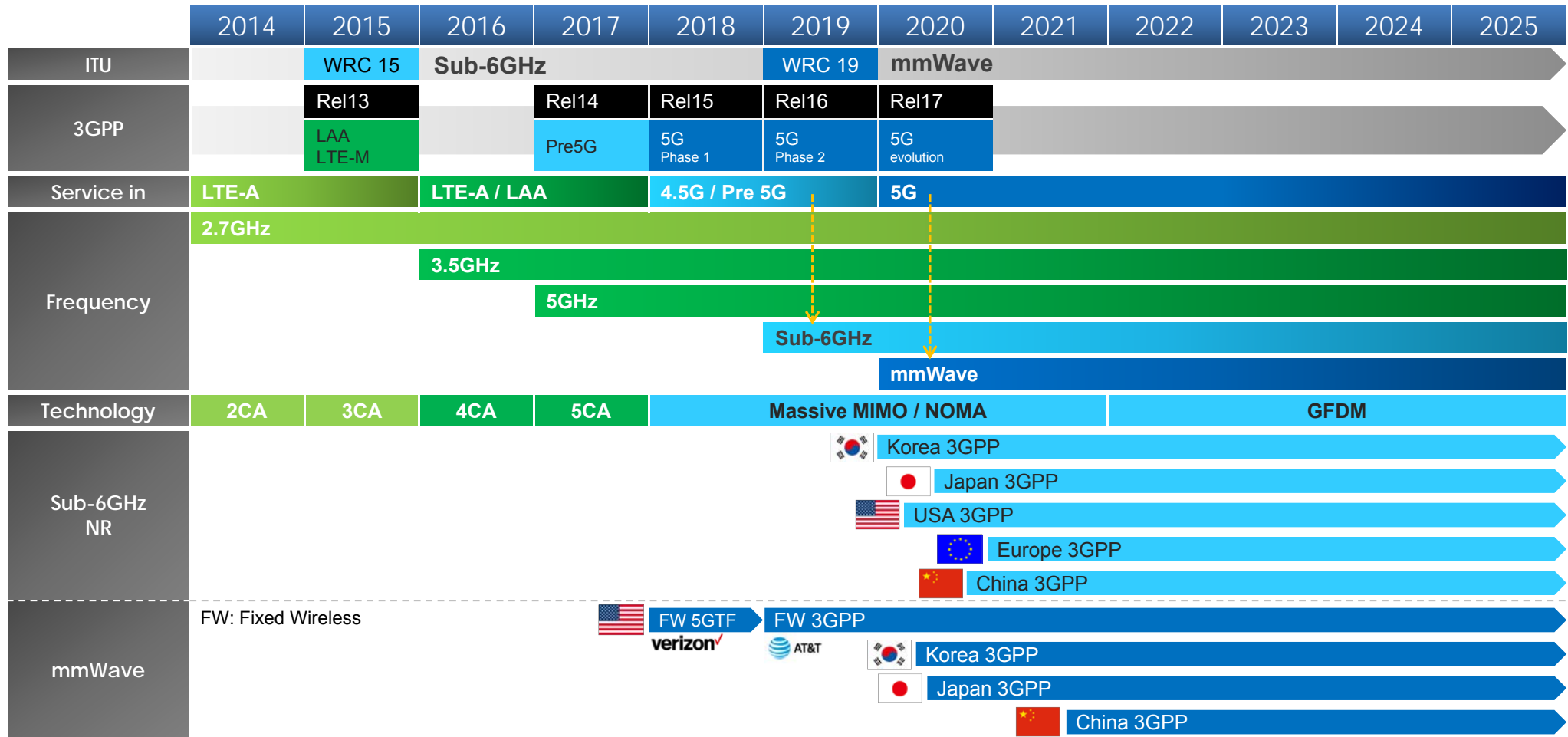

# Cellular 5G Spectrum

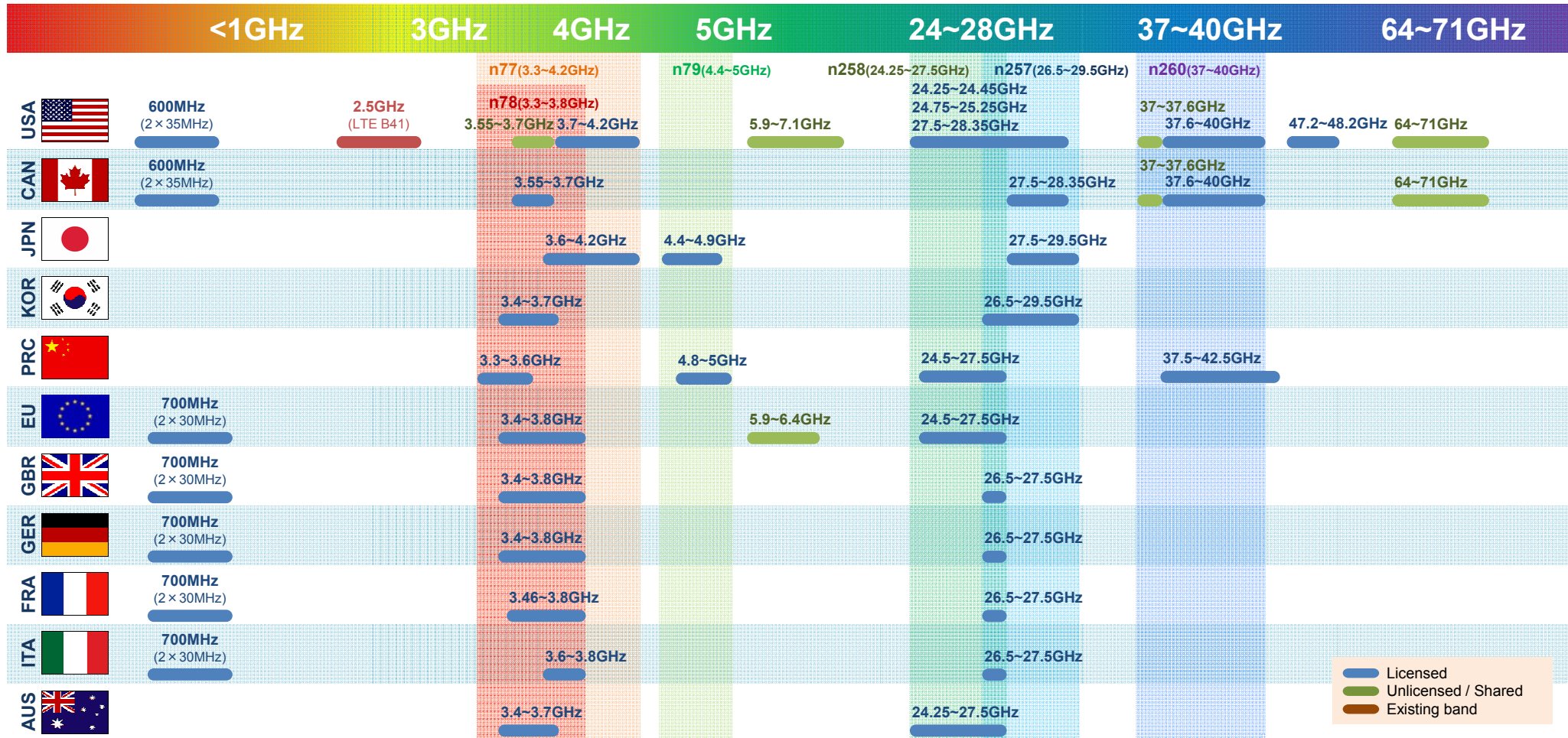

# 5G NR (Sub-6GHz) Block Diagram [ 1 ]

## TDK RF COMPONENTS

NO.	USAGE	CASE SIZE	TDK PART NUMBER	STATUS
1	Coupler for LB-HB (617-2700MHz)	1.0x0.5 t:0.32	<a href="#">TFSC10051700-2306A5X</a>	Sample
	Coupler for LB-n78 (617-3800MHz)	1.0x0.5 t:0.35	<a href="#">TFSC102250-2325A4</a>	Sample
2	Coupler for n77-LAA (3.3-5.95GHz)	1.0x0.5 t:0.35	<a href="#">TFSC10054625-2317A2</a>	MP
		1.0x0.5 t:0.45	<a href="#">HHM2952A2</a>	Sample
3	Coupler for JMB-LAA (1.42-5.95GHz)	1.0x0.5 t:0.35	<a href="#">TFSC103688-2314C1</a>	MP
3	Triplexer (LB-HB/n77-78/LAA)	2.5x2.0 t:0.65	<a href="#">TPX255925MT-7062B1</a>	Sample
4	Hybrid Triplexer (LB / JMB / HB)	3.5x3.5 t:1.0	<a href="#">TPX352690MT-7033C1-X</a>	Sample
5	BPF for n78 (3.3-3.8GHz)	2.0x1.25 t:0.65	<a href="#">DEA203550BT-2224A4-H</a>	Sample
		1.0x0.5 t:0.25	<a href="#">TFSB1A3550-1409A1</a>	Sample
	LPF for n78 (3.3-3.8GHz)	1.6x0.8 t:0.7	<a href="#">DEA163800LT-5017C1</a>	MP

## BLOCK DIAGRAM EXAMPLE

TDK Estimation

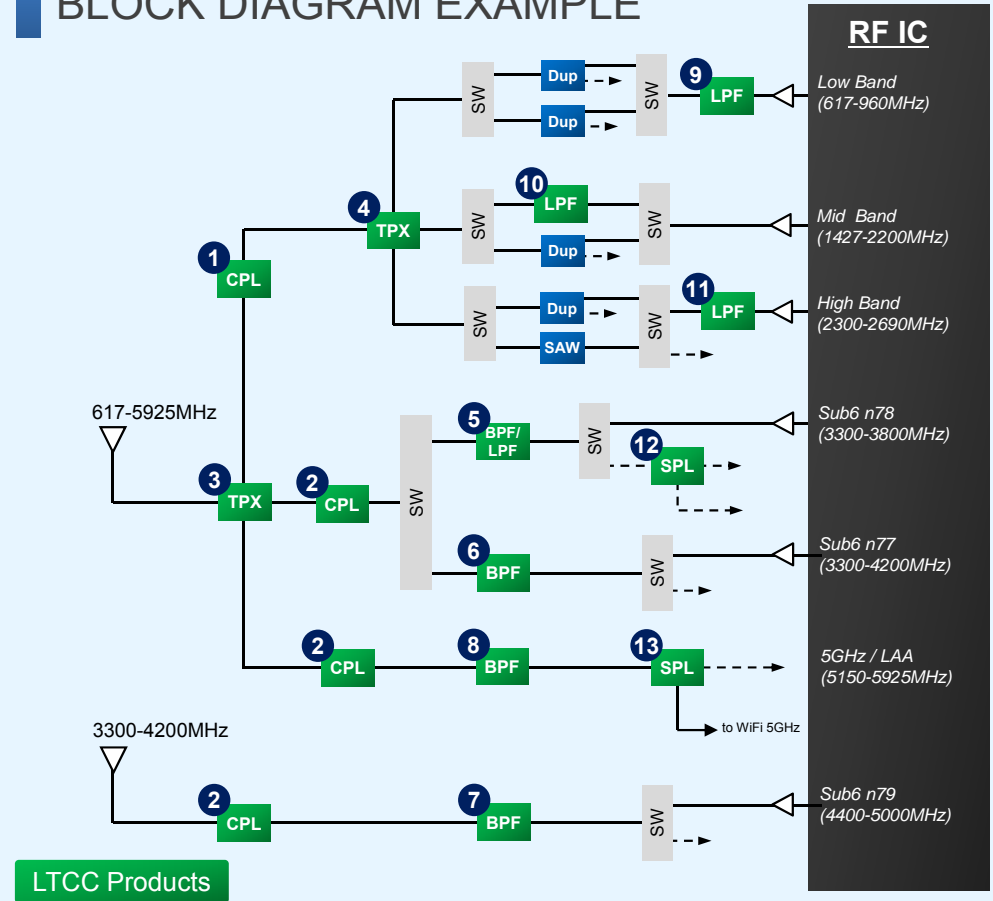

# 5G NR (Sub-6GHz) Block Diagram [ 2 ]

## TDK RF COMPONENTS

NO.	USAGE	CASE SIZE	TDK PART NUMBER	STATUS
6	BPF for n77 (3.3-4.2GHz)	2.5x2.0 t:0.65	<a href="#">DEA253750BT-2258A1</a>	Sample
		2.0x1.25 t:0.65	<a href="#">DEA203750BT-2292A1</a>	Sim
		1.0x0.5 t:0.25	<a href="#">TFBSB1A3750-1407A1</a>	Sample
		1.0x0.5 t:0.25	<a href="#">TFBSB1A3600-1408A1</a>	Sim
7	BPF for n79 (4.4-5.0GHz)	2.0x1.25 t:0.65	<a href="#">DEA204700BT-2307A1</a>	Sample
		1.0x0.5 t:0.25	<a href="#">TFBSB1A4700-1404B1</a>	Sample
8	BPF for LAA (5150-5925MHz)	1.6x0.8 t:0.65	<a href="#">DEA165538BT-2263A1-H</a>	Sample
9	LPF (617-960MHz)	1.6x0.8 t:0.7	<a href="#">DEA160960LT-5059A1</a>	MP
		0.65x0.5 t:0.3	<a href="#">TFSL060960-4409B2</a>	Sample
10	LPF (1880-2025MHz)	1.0x0.5 t:0.4	<a href="#">DEA102025LT-6326B1</a>	MP
		0.65x0.5 t:0.3	<a href="#">TFSL062025-4406C1</a>	Sample
11	LPF (617-2690MHz)	1.6x0.8 t:0.7	<a href="#">DEA162690LT-5064A1</a>	MP
12	Splitter for B42/43 (3.4-3.8GHz)	0.65x0.5 t:0.3	<a href="#">TFSC063600-6116A1</a>	Sample
13	Splitter (4900-5950MHz)	0.65x0.5 t:0.3	<a href="#">TFSC065425-6102A1</a>	MP

## BLOCK DIAGRAM EXAMPLE

TDK Estimation

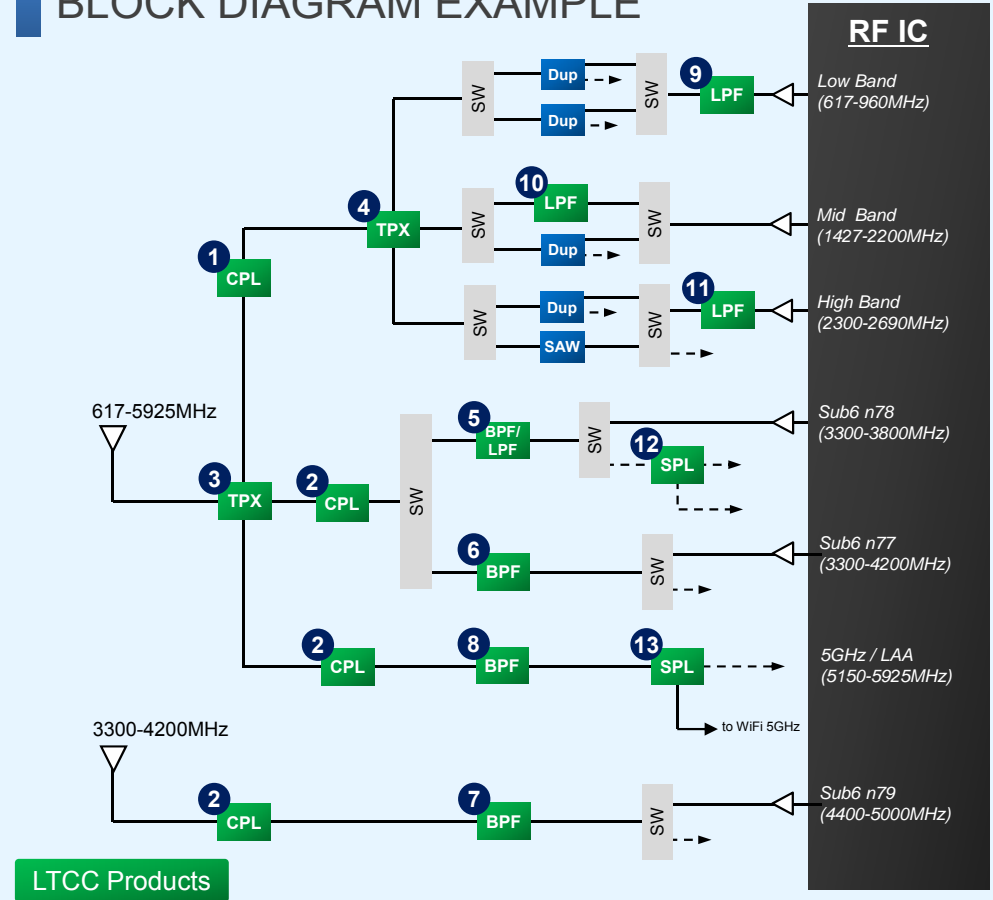

Attracting Tomorrow



# PCB Layout Design Case Studies for RF Components

---

Do you know the following fact?

PCB GND design significantly impact  
RF component performance...

- In this section, we will introduce example case studies and their countermeasures.

# PCB Ground Design Impact

## 1608 size BPF for 2.4GHz

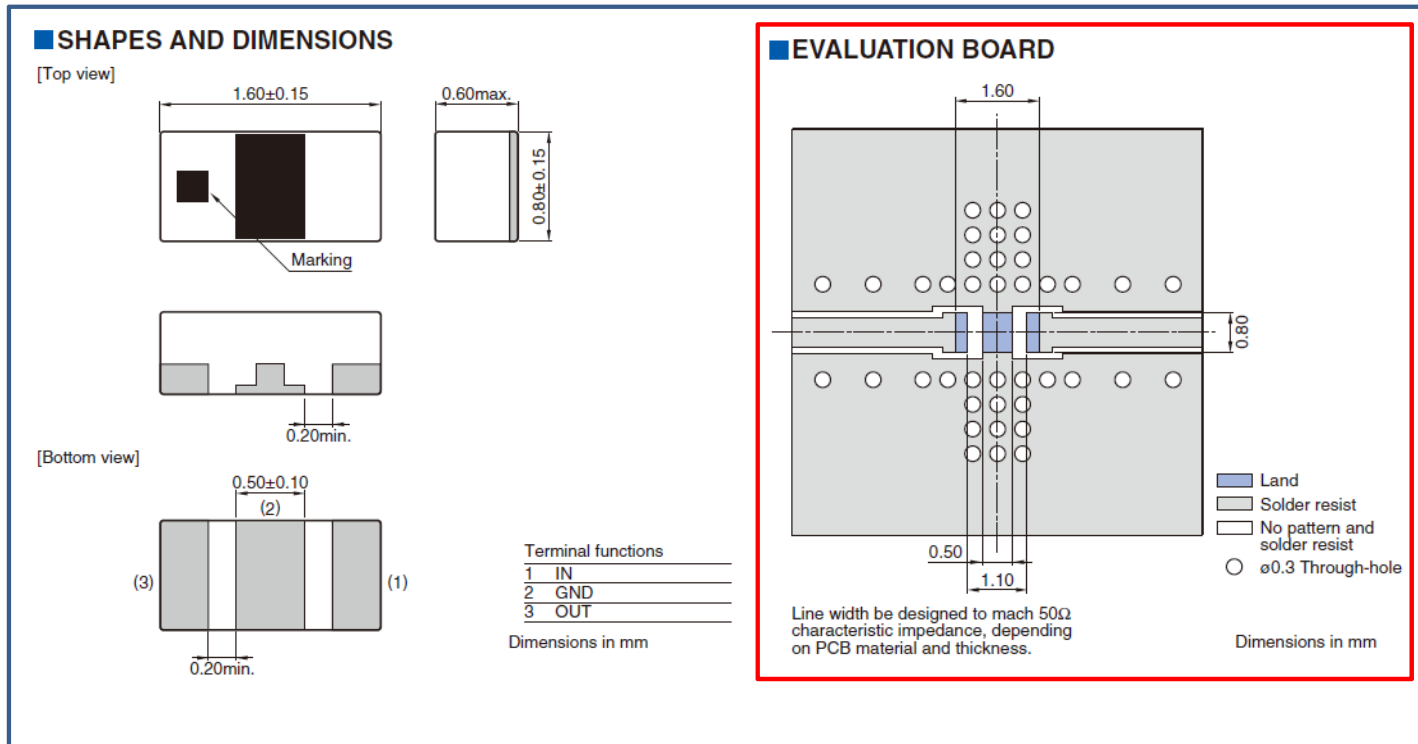

# Example of Via Holes Layout Impact

## Simulation Models

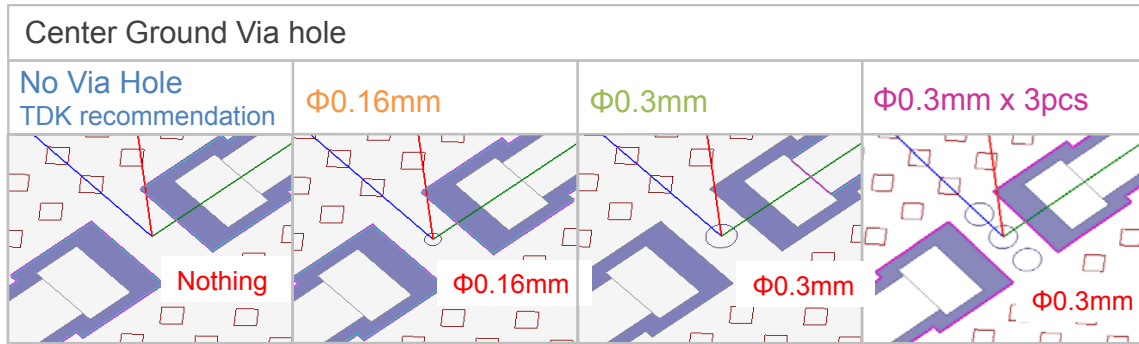
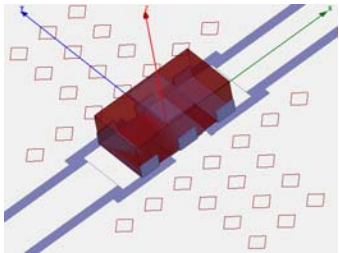

## Simulation Results

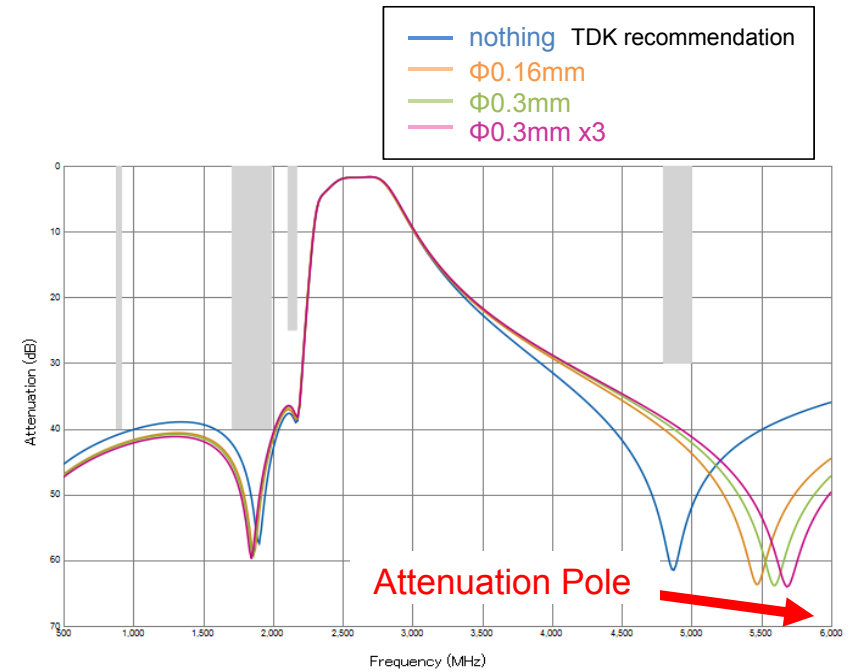

➤ Existence, diameter and number of via holes affect RF component performance

# Example of Soldering Pads Layout Impact

## Simulation Models

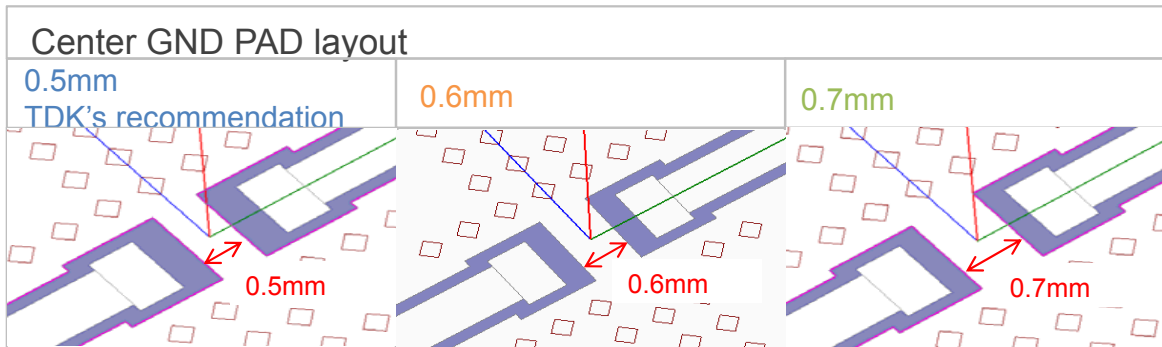
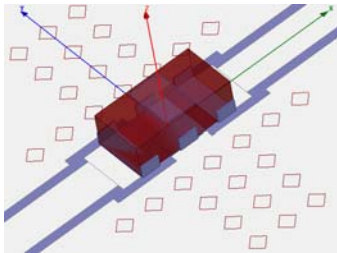

## Simulation Results

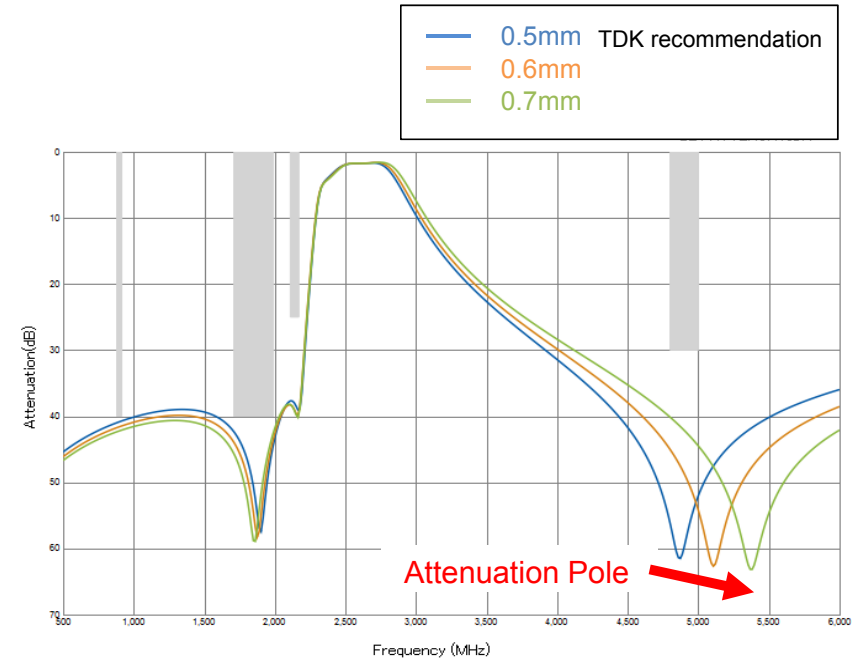

➤ Changing distance between two pads affect RF component performance

## ■ Countermeasure #1

### During PCB Design Stage:

- Follow pad layout and via holes pattern recommended in TDK datasheet as close as possible for optimal performance

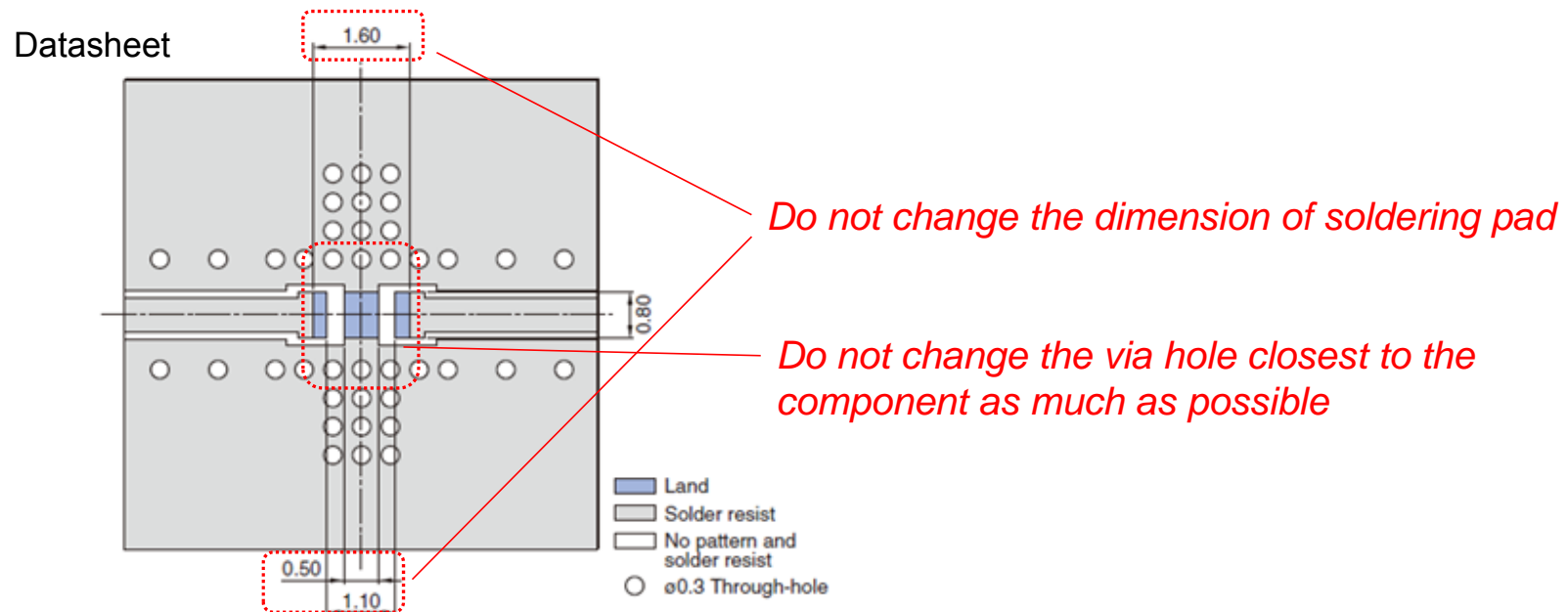

## TDK has dedicated RF FAE Team

Therefore...

- We can estimate the performance by simulation when you provide TDK with PCB information (such as DXF) before the PCB design is fixed
- We can tune & measure with matching elements when you send TDK actual PCB/product/prototype after the PCB design is fixed

**TDK FAE Team welcome your request anytime**  
**Please do not hesitate to contact us!**

# How to Minimize Shielding Cans Impact

Simulation model for shielding can influence by Z direction

## Simulation Models

- Shielding Can model
  - Perfect conductor
  - Shield thickness 0.1mm

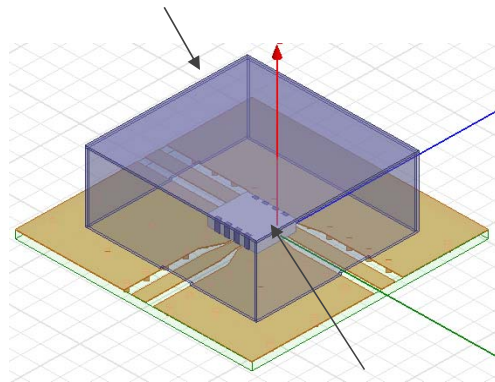

DPX252170DT-5051D1

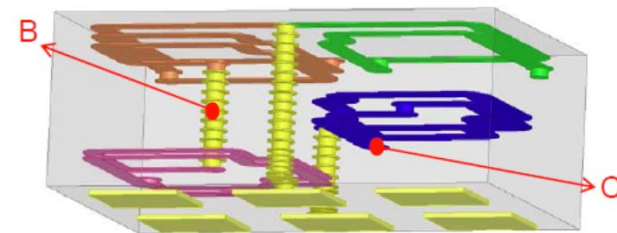
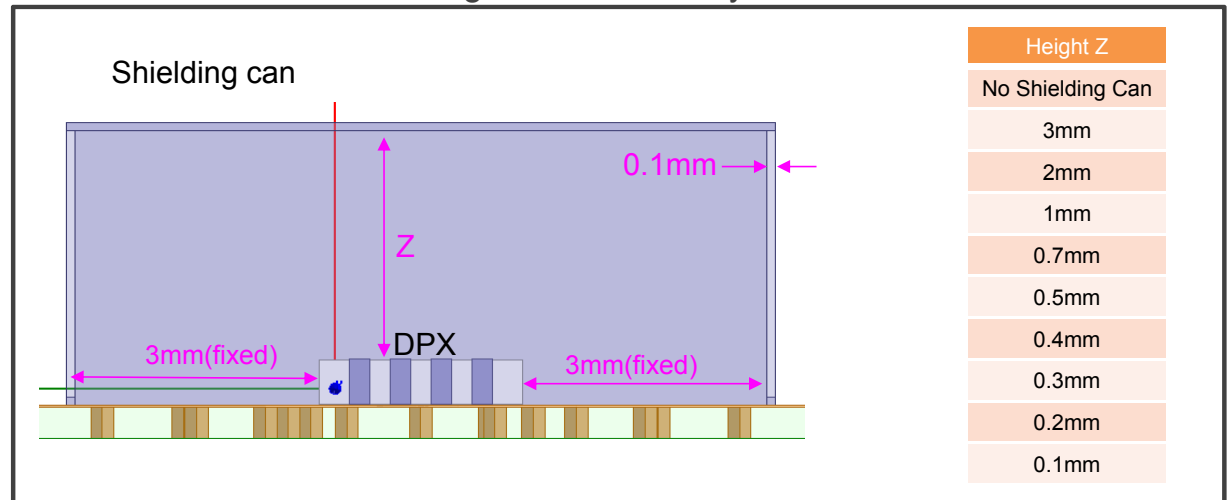

# Simulation Results

Z direction impact

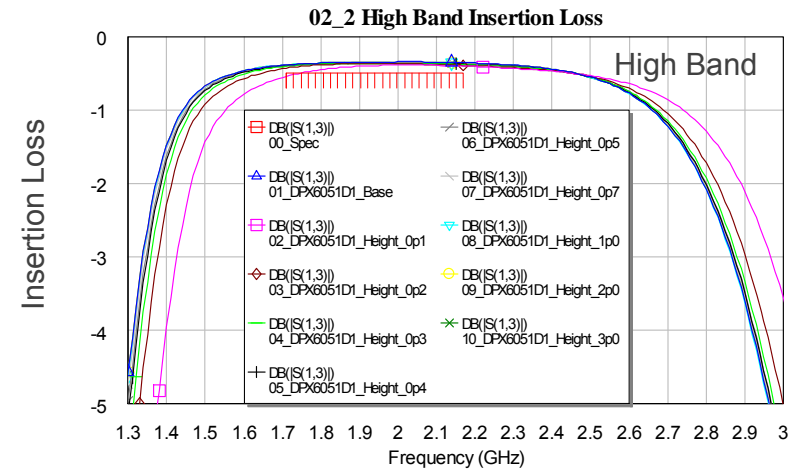
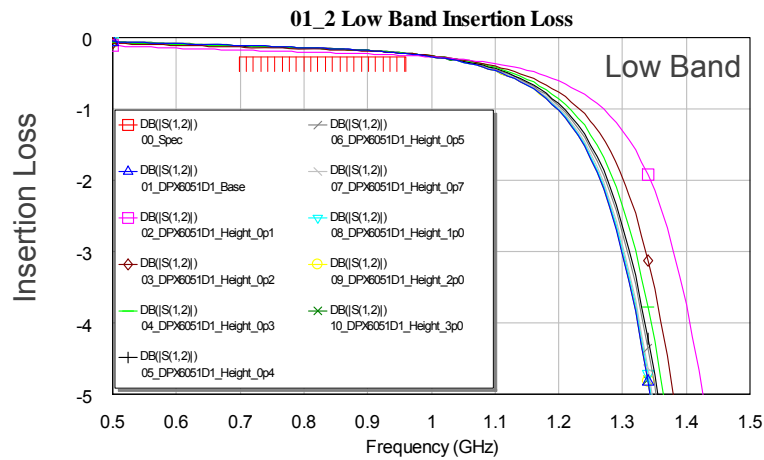
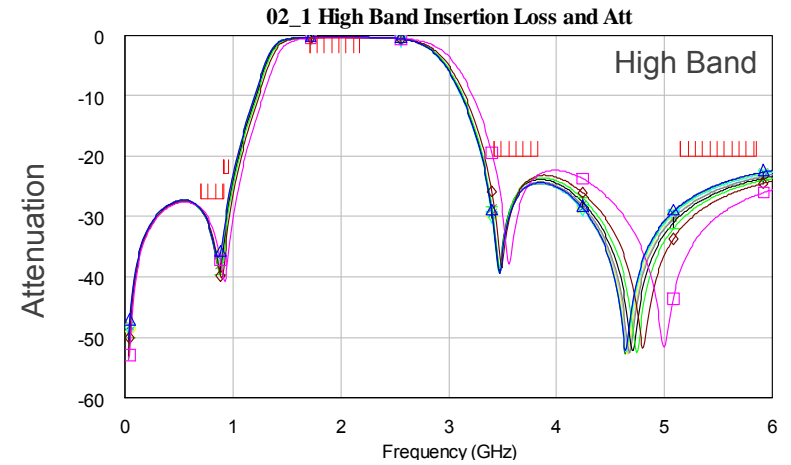
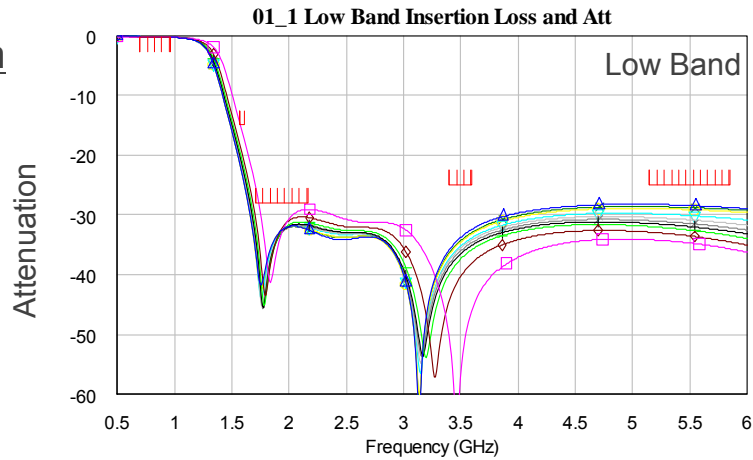

These results indicate that...

When designing shielding cans for your product, please take into considerations the electrical characteristics of RF components

# Countermeasure #1

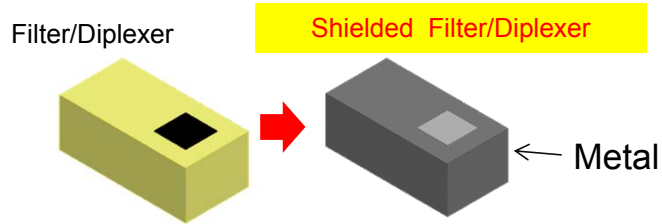

**Merit :**  
 Unaffected by surrounding components and shielding cans

**Demerit :**  
 Performance decrease compared to similar case size (about same performance as 1 case size smaller)

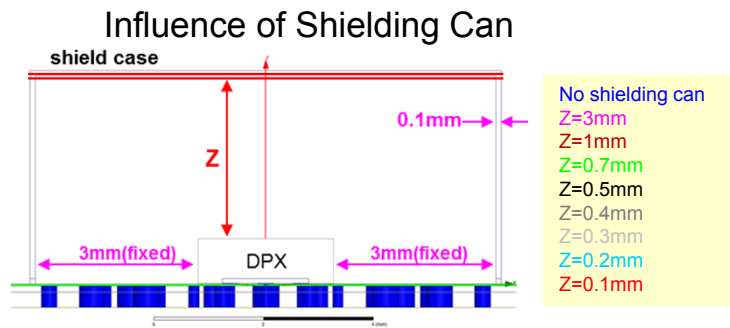
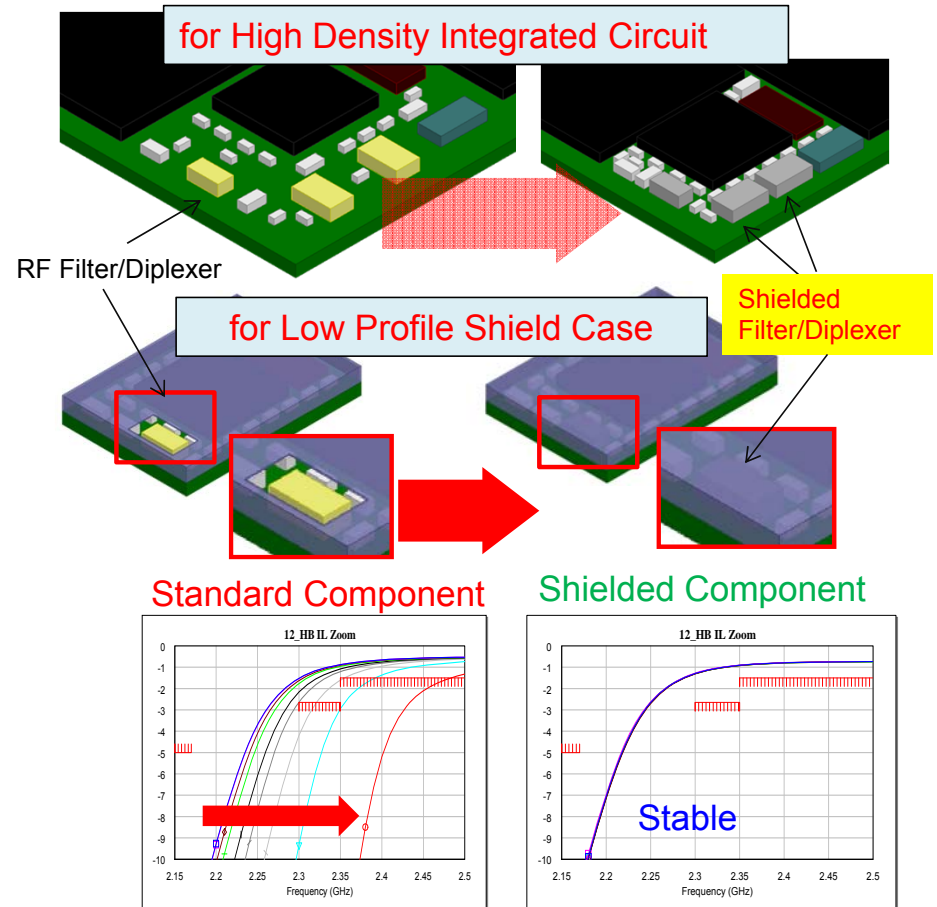

## TDK has dedicated RF FAE Team

Therefore...

- We can estimate the shielding can impact by simulation during design stage
- We can tune, measure and propose matching elements when provided with PCB/product

**TDK FAE Team welcome your request anytime**  
**Please do not hesitate to contact us!**

Attracting Tomorrow



# Chip Antenna Design Guideline & Technical Support

---

GND impact for RF filters was introduced in the last section

For antenna performance,  
GND design is much more important

- In this section, we will introduce factors that affect chip antenna performance and design support from TDK

# Example of PCB Size Impact for Antenna

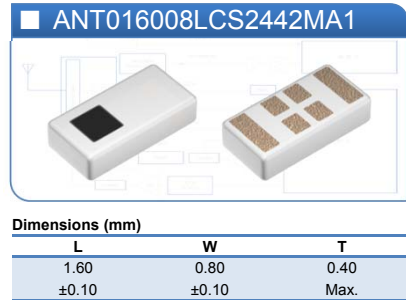

## EVALUATION BOARD

Antenna Location: Center  
 Board size: L x 20 x 1 mm<sup>2</sup>  
 Antenna keep out area: 5 x 3 mm<sup>2</sup>

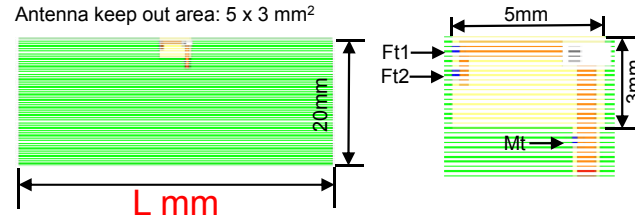

## VSWR & EFFICIENCY (SIMULATION RESULTS)

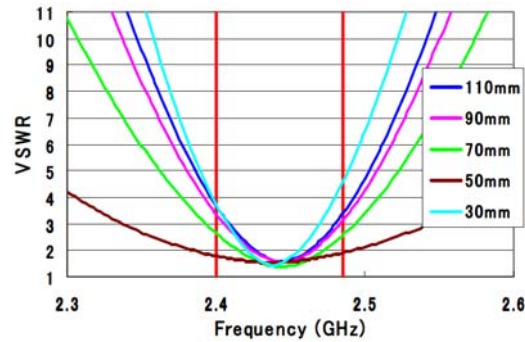
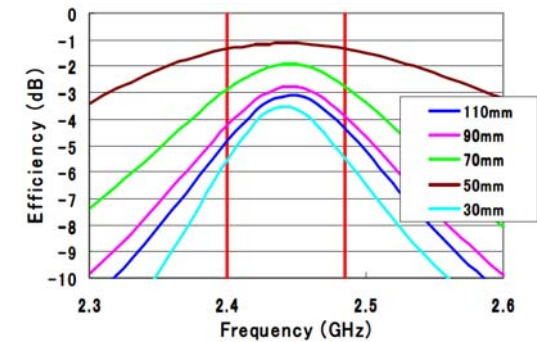

Item	VSWR			Efficiency(dB)		
	Frequency(GHz)	2.4	2.442	2.485	2.4	2.442
L=110mm	3.7	1.6	3.4	-4.81	-3.13	-4.34
L=90mm	3.4	1.6	3.1	-4.23	-2.80	-3.86
L=70mm	2.6	1.4	2.6	-2.87	-1.92	-2.74
L=50mm	1.8	1.6	1.9	-1.35	-1.14	-1.34
L=30mm	3.7	1.5	4.6	-5.54	-3.56	-5.46

## MAX EFFICIENCY & BANDWIDTH (SIMULATION RESULTS)

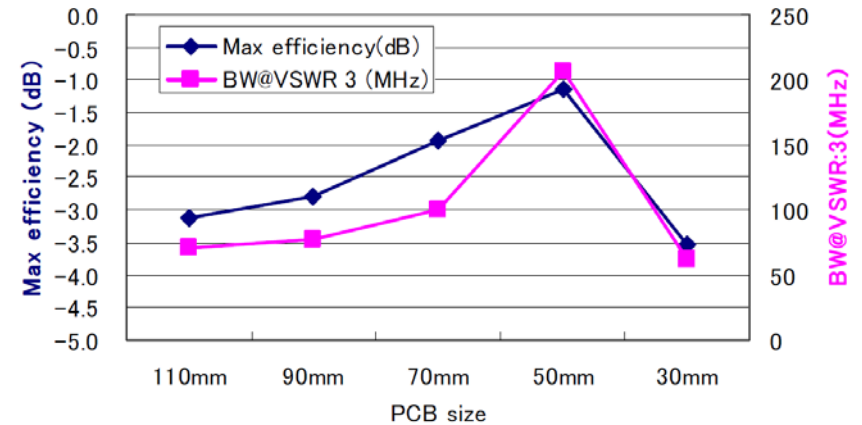

PCB Size	110mm	90mm	70mm	50mm	30mm
Max efficiency(dB)	-3.1	-2.8	-1.9	-1.1	-3.5
BW@VSWR 3 (MHz)	70.9	77.8	100.4	206.8	61.7

## TECHNICAL REMARKS

- For maximum efficiency with center mount antenna: length L = 50

# Factors Affecting Antenna Performance

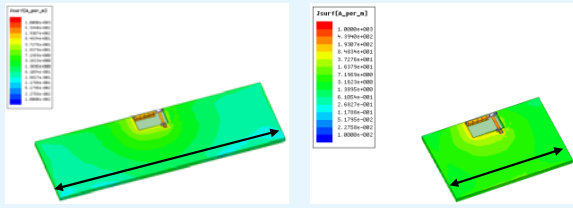

## | PCB GND Size

- PCB GND size is one of the factors that determine the performance of antenna
- There is an optimal size at each frequency

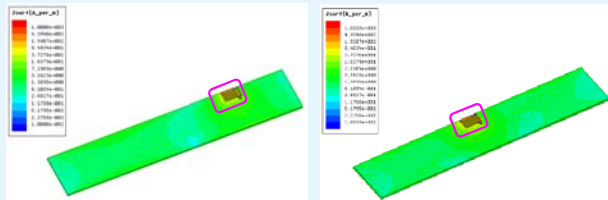

## | Antenna Location of PCB

- Antenna Location is one of the factors that determine the performance of antenna
- There is an optimal location for each PCB size

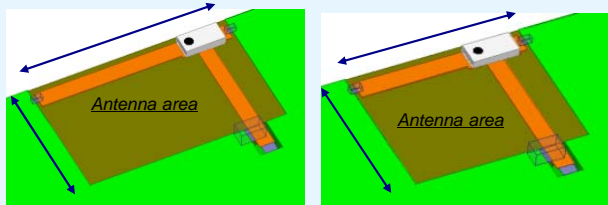

## | Antenna Keep-Out Area Size

- Antenna area is one of the factors that determine the performance of antenna
- Bigger is better for antenna performance

Antenna performance will depend of each product and it is important to find best layout in early design stage...

Therefore..

**TDK FAE team can provide antenna technical design support for your product**

# ■ Chip Antenna Simulation Support

Purpose: Recommend optimal antenna PCB layout

- Customer Action: Send PCB information to TDK

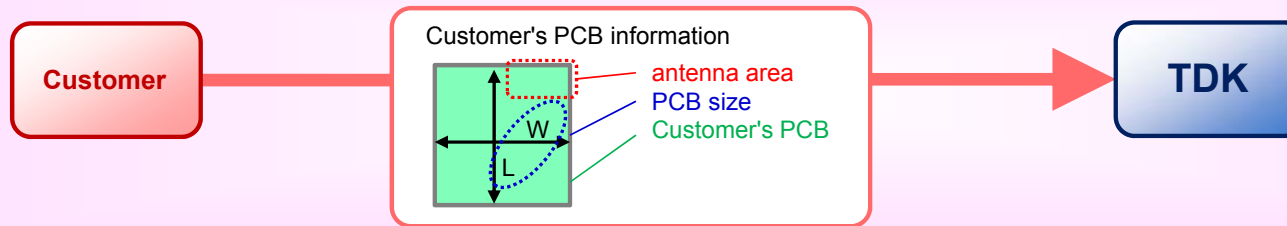

- TDK Action: Propose optimal PCB layout by simulation

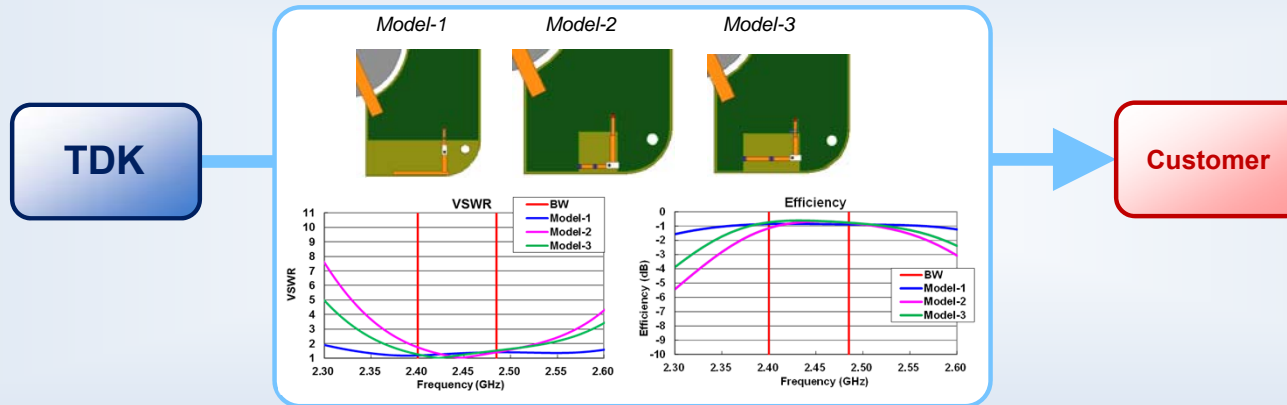

# ■ Chip Antenna Measurement Support

Purpose 1: Recommend optimal tuning elements

Purpose 2: Provide actual antenna performance by measurements

- Customer Action: Send prototype PCB/product to TDK

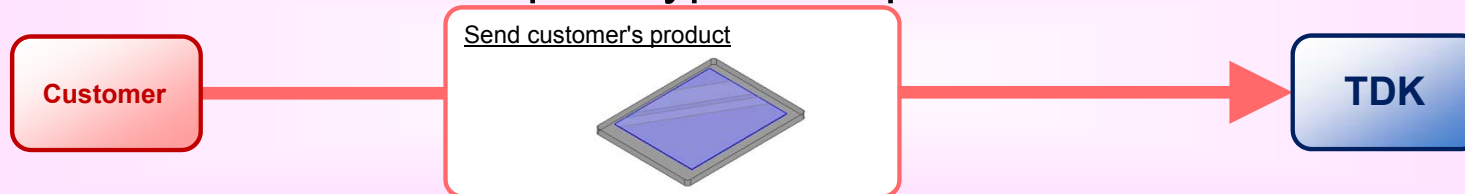

- TDK Action: Provide performance & suitable tuning element value

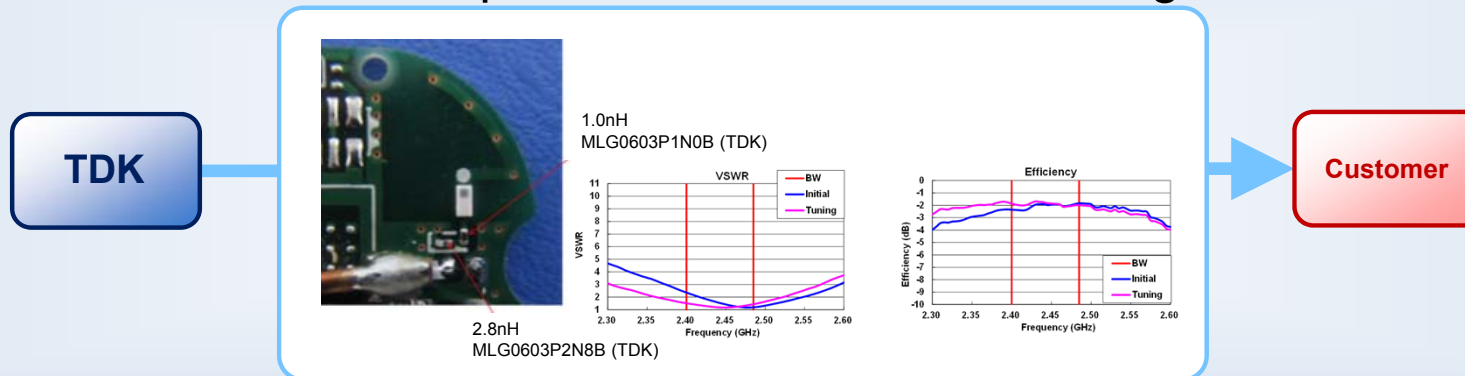

# Comparison of Corner-Mounting Antennas

TYPE ▶

▶ CERAMIC CHIP

▶ PCB TRACE

▶ MECHANICAL

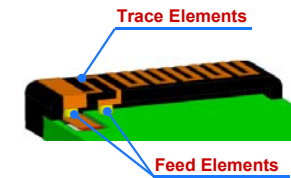
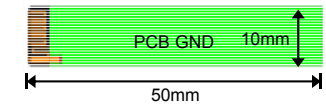
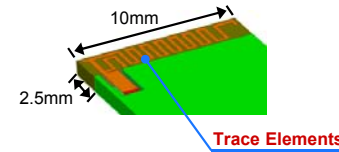
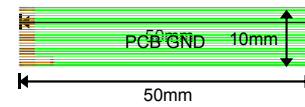
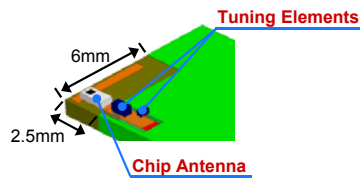
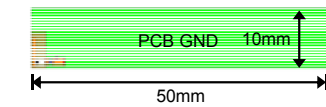

<b>Keep-out Area</b>	6 × 2.5 mm <sup>2</sup>	10 × 2.5 mm <sup>2</sup>	10 × 3.5 × 2 mm <sup>3</sup>
<b>Example Efficiency</b>	-2.4dB	-3dB	-2.5dB
<b>Feeding Structure / Cost</b>	Strip line / \$0	Strip line / \$0	Spring contact, C-Clip / \$0.1
<b>Tooling Cost</b>	N/A	N/A	~ \$3000+
<b>Design / Simulation</b>	TDK support (EM simulator: HFSS)	By customer	By customer
<b>Tuning Method</b>	<ul style="list-style-type: none"> <li>• By changing tuning elements (caps and inductors)</li> <li>• No need to revise PCB</li> </ul>	<ul style="list-style-type: none"> <li>• By changing length of trace elements</li> <li>• Need to revise PCB afterward</li> </ul>	<ul style="list-style-type: none"> <li>• By changing length of trace elements</li> <li>• Need to revise mechanical structure afterward</li> </ul>
<b>Evaluation</b>	TDK support (in-house Starlab System)	By customer (specialized equipment require)	By customer (specialized equipment require)

# Comparison of Center-Mounting Antennas

Customer request: Convert single band antenna to dual band antenna

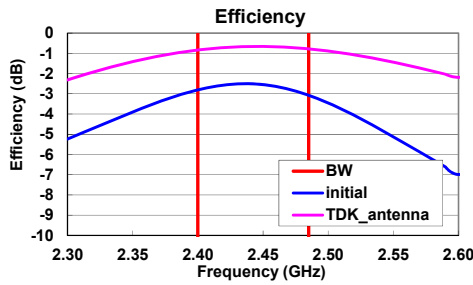
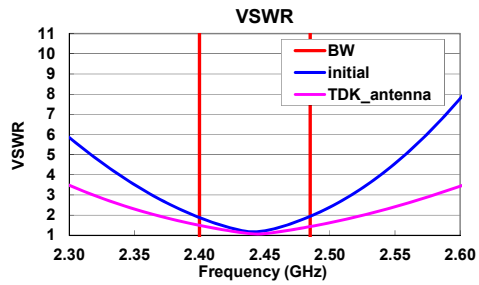
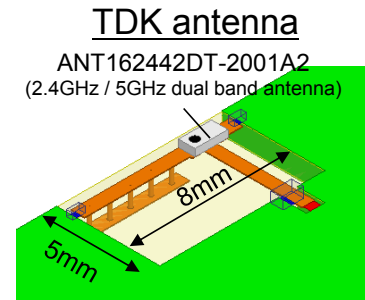
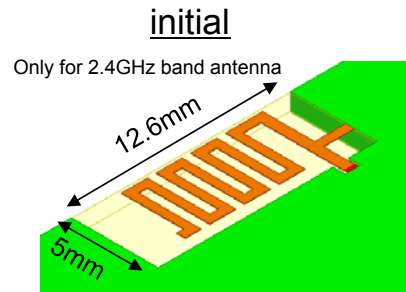
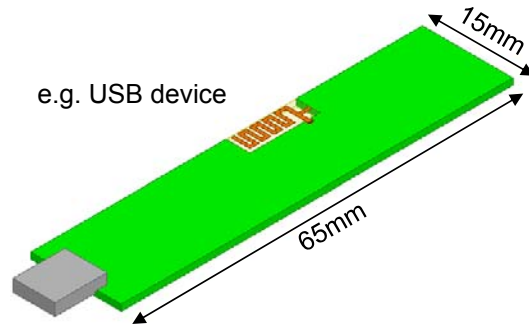

	initial			TDK antenna		
Frequency[GHz]	2.4	2.442	2.485	2.4	2.442	2.485
VSWR	1.88	1.17	1.94	1.49	1.07	1.43
Efficiency[dB]	-2.80	-2.50	-2.96	-0.83	-0.65	-0.75

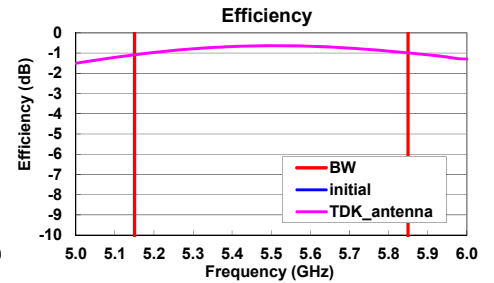
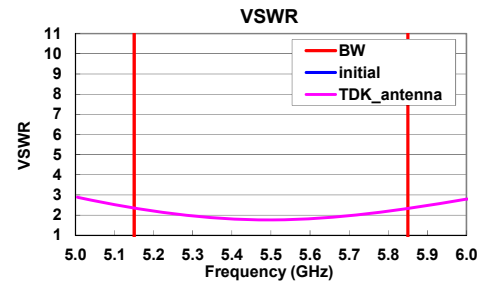

	initial			TDK antenna		
Frequency[GHz]	5.15	5.5	5.85	5.15	5.5	5.85
VSWR	#NUM!	#NUM!	#NUM!	2.35	1.76	2.33
Efficiency[dB]	-20.00	-20.00	-20.00	-1.08	-0.63	-0.99

➤ TDK Chip antenna can achieve dual band radiation without extending antenna area

# ■ Chip Antenna Cost Advantage

TDK antenna is SMD type so ...

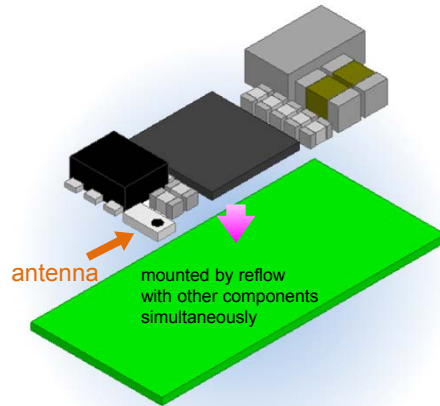

connector & cable : **NOT necessary**

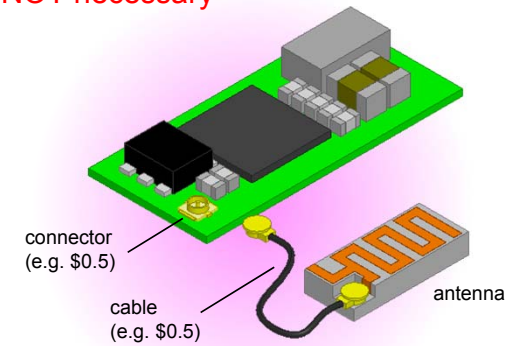

spring connector and manual assembly cost : **NOT necessary**

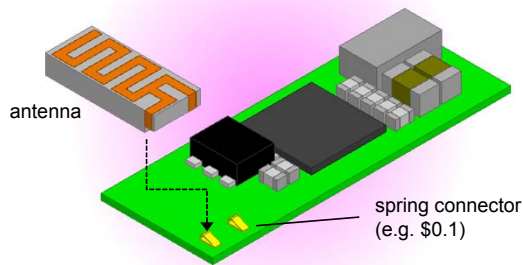

Antenna initial design cost : **NOT necessary**

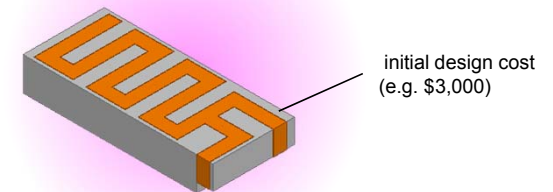

# Chip Antenna Design Support

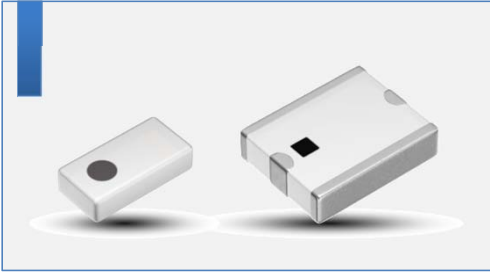

## FEATURES

- Ultra small & low profile design (1608)
- High performance / high reliability
- Capable of supporting multi-bands
- Smallest keep-out area in industry
- Linear polarization & omnidirectional

## APPLICATIONS

- WLAN: 2.4GHz and 5GHz Wi-Fi
- PAN: Bluetooth / Bluetooth Smart / BLE / Zigbee
- GNSS: GPS / GLONASS / Galileo / Beidou
- Cellular high band LTE [B40/B41]
- Automotive: DSRC

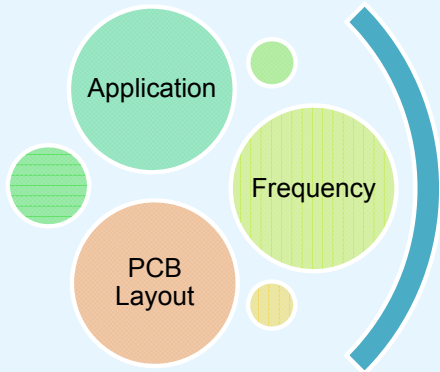

## Product Selection

- With expertise in **platform antenna design** and more than **20 years** in manufacturing LTCC RF products, TDK can help you select the right component based on **application, frequency, and PCB layout needs**

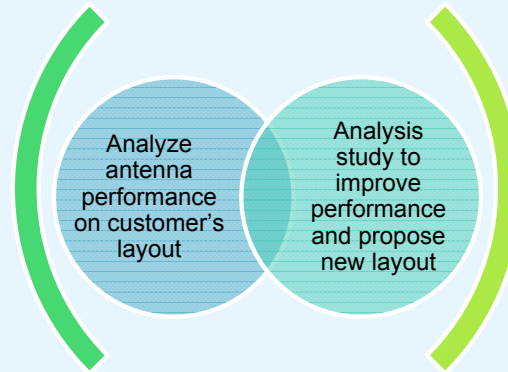

## Design Simulation

- With **state-of-the-art software** (Agilent ADS, Ansys HFSS, Solidworks) and a full engineering team, TDK can provide you with **free-of-charge simulation** support along with **recommended PCB layout** for **optimal in-application performance**

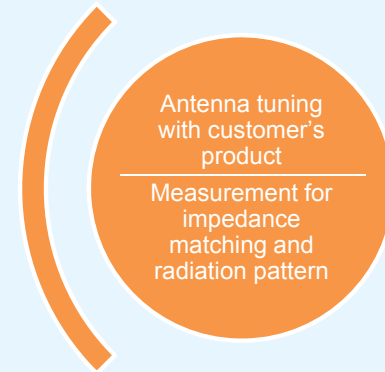

## Design Evaluation

- With our fully-equipped in-house lab (Starlab by Satimo), TDK can support measurements with your product for **impedance matching and radiation pattern** to provide **tuning work and propose matching components**

## ■ Simulation & Evaluation Technology

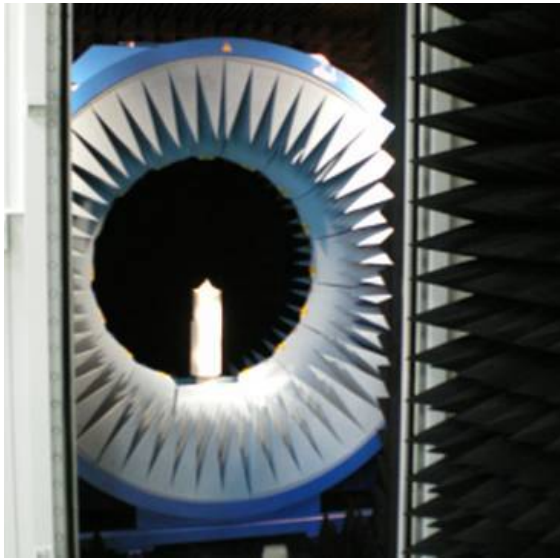

TDK Dalian, China

TDK, Japan



### Specification of StarLab

- Frequency Range: 0.8 – 18.0GHz
- Maximum DUT Size:
  - 40cm @ 0.9GHz - @ 2.4GHz
  - 35cm @ 5.8GHz
- Measurement Uncertainties of peak gain:
  - $< \pm 1.1\text{dB}$  @ 0.8GHz – 1.0GHz
  - $< \pm 0.8\text{dB}$  @ 1.0GHz – 6.0GHz
- Measurement Repeatability:
  - $\pm 0.3\text{dB}$  (Peak Antenna Gain)
- Dynamic Range:
  - 50dB (VNA dependent)

Attracting Tomorrow



# TDK RF Product Center Website Walkthrough

---

# TDK Product Center | RF Components

<https://product.tdk.com/info/en/products/rf/index.html>

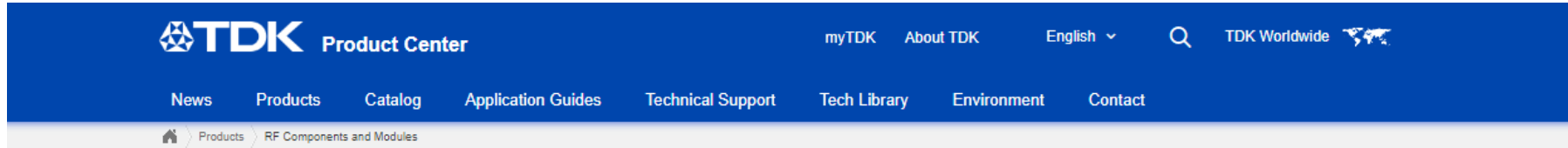

TDK Product Center myTDK About TDK English TDK Worldwide

News Products Catalog Application Guides Technical Support Tech Library Environment Contact

Products RF Components and Modules

## RF Components and Modules

- Product Top Page
- Tech Notes
- Technical Support Tools
- FAQ

### Product Lineup



- Filters
- Diplexers
- Triplexers
- Baluns
- Directional Couplers
- Chip Antennas
- Isolators / Circulators
- Modules

Important Notes TDK

### Tech Notes



- General Technical Information (DEA, DPX, TPX, HHM, ANT, DLF Series) **New**
- Chip Antennas Selection Guide **New**

Email Newsletter Registration

FAQ Questions frequently asked by our customers

Sample Kits RF Components and Modules

# Chip Antenna Selection Guide



Chip Antennas

Product Top Page | Catalog | Tech Notes | Technical Support Tools | FAQ

## Chip Antennas Selection Guide

<https://product.tdk.com/info/en/products/rf/rf/antenna/technote/selection-guide.html>

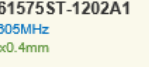
Click part number in the diagram for more details.

Commercial Grade		Single Band	Dual Band	Triple Band	
Chip Antenna Mounting Guideline	Application	Frequency Band			
		Sub GHz Band	GNSS Band	2.4GHz Band	5GHz Band
<b>PCB Center-edge Mounting Position</b>  Mount at center edge of PC Board (Surround by GND in 3 directions)	Single Band		<b>ANT016008LCD1575MA1</b> 1574-1576MHz / 2400-2484MHz 1.6x0.8x0.4mm	<b>ANT016008LCS2442MA1</b> 2400-2484MHz 1.6x0.8x0.4mm	<b>ANT165550ST-1003A1</b> 5150-5950MHz 1.6x0.8x0.4mm
	Dual Band		<b>ANT016008LCD1575MA1</b> 1574-1576MHz / 2400-2484MHz 1.6x0.8x0.4mm	<b>ANT162442DT-2001A2</b> 2400-2484MHz / 5150-5850MHz 1.6x0.8x0.4mm	
	Triple Band		<b>ANT161575TT-3000A1</b> 1574-1577MHz / 2400-2484MHz / 5150-5850MHz 1.6x0.8x0.4mm		
<b>PCB Corner Mounting Positions</b>  Mount at corner of PC Board (Surround by GND in 1 or 2 directions)  Mount near corner of PC Board (Surround by GND at 3 directions)	Single Band	<b>ANT160920ST-1204A1</b> 902-930MHz 1.6x0.8x0.4mm	<b>ANT161575ST-1202A1</b> 1557-1605MHz 1.6x0.8x0.4mm	<b>ANT016008LCS2442MA2</b> 2400-2484MHz 1.6x0.8x0.4mm	<b>ANT165550ST-1003A1**</b> 5150-5950MHz 1.6x0.8x0.4mm
	Dual Band			<b>ANT162442DT-2200A1</b> 2400-2484MHz / 5150-5850MHz 1.6x0.8x0.4mm	
	Triple Band		<b>ANT025020LCT1575MA1</b> 1574-1577MHz / 2400-2484MHz / 5150-5850MHz 2.5x2.0x0.6mm		

\*\* : Please mount at near the corner of PC Board for these items.

### Tech Notes

Chip Antennas Selection Guide **New**

Design Note "Information on substrates, mounting positions, and matching and tuning" **New**

Easy to select chip antenna for your application and antenna location

# Chip Antenna Design Notes & Simulation Models

**Design Note** <https://product.tdk.com/info/en/products/rf/rf/antenna/technote/designnote.html>

## Tech Notes

Chip Antennas Selection Guide New

General Technical Information (ANT Series) New



Design Note "information on substrates, mounting positions, and matching and tuning" New

## Chip Antennas

Product Top Page
Catalog
Tech Notes
FAQ

**ANT016008LCD1575MA1**

Application: W-LAN, Bluetooth, GPS

Cellular Band: [Blank]

Application Grade: Commercial Grade

Series: ANT

Status: Production

Size: Length(L) 1.60mm ±0.10mm, Width(W) 0.80mm ±0.10mm, Thickness(T) 0.40mm Max.

Electrical Characteristics: Start/Stop Frequency 1574 to 1576MHz, 2400 to 2484MHz

PDF file of this page

Buy Now

Contact

Documents: Catalog / Data Sheet, General Technical Information, Selection Guide

Technical Support Tools: [myTDK] [Model Libraries] HFSS 3D Components Libraries ALL

## HFSS Black Box Model

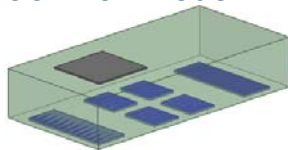

## ANSYS® HFSS™ Simulation Model

[https://product.tdk.com/info/en/technicalsupport/tvcl/ansys\\_hfss/antenna/index.html](https://product.tdk.com/info/en/technicalsupport/tvcl/ansys_hfss/antenna/index.html)

## SIMULATION STUDY | MATCHING & TUNING

**ANT016008LCS2442MA1**

Antenna Location: Center  
Board size: 120 x 65 x 1 mm<sup>3</sup>  
Antenna keep out area: 5 x 3 mm<sup>2</sup>

Dimensions (mm)	L	W	T
1.60	5.80	0.40	Max.
±0.10	±0.10		

**EVALUATION BOARD**



**TECHNICAL REMARKS**

Value of tuning components depend on:

- PCB Size
- Antenna Location
- Other mechanical conditions

Frequency tuning  
Matching Tuning  
(Inductor or Capacitor)

Impedance Tuning

**FREQUENCY TUNING (SIMULATION RESULTS)**

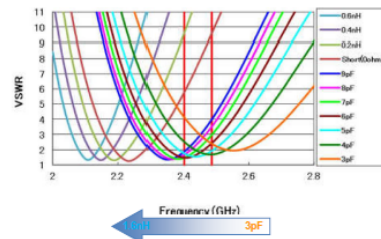

Frequency tuning value	0.6nH	0.4nH	0.2nH	short	9pF	8pF	7pF	6pF	5pF	4pF	3pF
Center Frequency (GHz)	2.112	2.152	2.194	2.242	2.357	2.370	2.388	2.410	2.440	2.485	2.555

**IMPEDANCE MATCHING (SIMULATION RESULTS)**

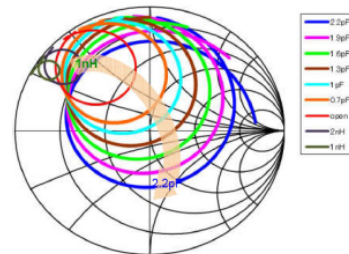

Easy to design by antenna design guide and HFSS model

# Chip Antenna Simplified Simulation Tool

**Product**

ANT016008LCS2442MA2

Length(L) 1.60mm ±0.10mm      Width 0.80mm



Antenna simplified Simulator

**Evaluation Board**      **Tips for simulation >**

A characteristics simulation can be performed by moving the slider.

**whole PCB**      **off GND area**

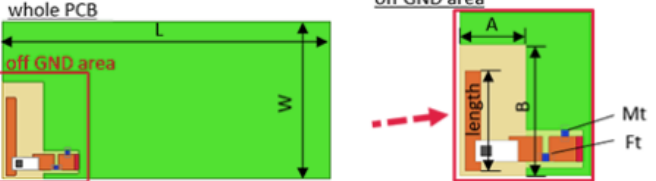

L       A  
 W       B

VSWR & Efficiency @ 2.4GHz band

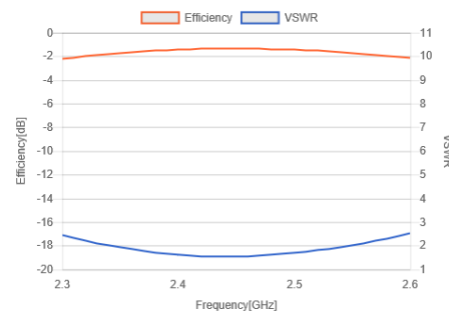

Electrical Characteristics

2.442GHz	
Efficiency[dB]	-1.35
VSWR	1.53
Peak Gain[dBi]	1.39
Recommended Element Value	
Mt	4.5nH
Ft	1.5nH
Pattern Length	
Length	3.68mm

Radiation Pattern (linear polarization) @ 2.442GHz

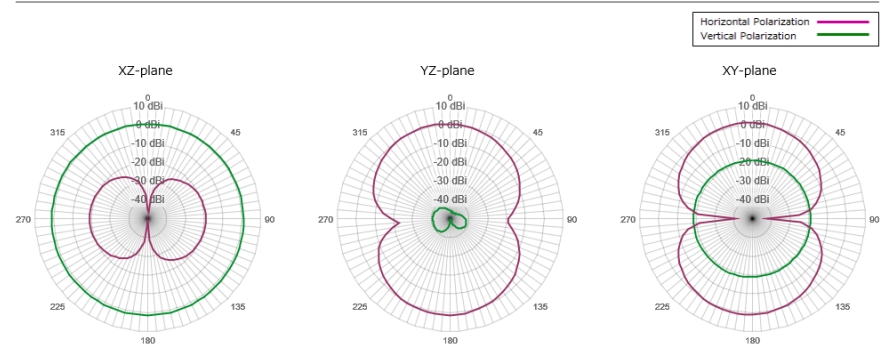

You can roughly check chip antenna performance and matching components value with simplified simulation tool

<https://product.tdk.com/en/search/rf/rf/antenna/simulation>

# S-Parameter for all RF Components

Search by Characteristics

## Product research results table

[Current Search Conditions] Cellular Band: B1 [clear](#) Product Status: Production [clear](#)

[Compare](#) [Catalog / Data Sheet](#) [Simulation Model](#)

Check	Catalog / Data Sheet	Images	Part No.	Distributor Inventory	Brand	Simulation Model	Apps.	Band	Filter Type	Start Freq. / MHz	Stop Freq. / MHz
<input type="checkbox"/>			<a href="#">DEA101990LT-6302B1</a>	<a href="#">Buy Now</a>	TDK	S	GSM W-CDMA LTE	Band 1/2/3/4/9/10/25/33/35/36/37/39/66	LPF	1710	
<input type="checkbox"/>			<a href="#">DEA161990LT-1182A8</a>	<a href="#">Buy Now</a>	TDK	S	GSM W-CDMA LTE	Band 1/2/3/4/9/10/25/33/35/36/37/39/66	LPF	1710	
<input type="checkbox"/>			<a href="#">DEA162025LT-5003C3</a>	<a href="#">Buy Now</a>	TDK	S	GSM W-CDMA LTE	Band 1/2/3/4/8/9/10/11/21/23/24/25/32/33/34/35/36/37/39/45/50/51/65/66/70/74/75/76	LPF	880	
<input type="checkbox"/>			<a href="#">DEA162025LT-5003C3</a>	<a href="#">Buy Now</a>	TDK	S	GSM W-CDMA LTE	Band 1/2/3/5/6/8/9/10/11/21/23/24/25/32/33/34/35/36/37/39/45/50/51/65/66/70/74/75/76	Balanced		

## Product micro page



Images are for reference only and show exemplary products.

RoHS REACH SVHC-Free Halogen Free Lead Free

PDF file of this page

Buy Now

Contact

Documents

- Catalog / Data Sheet
- General Technical Information

Technical Support Tools

- S-parameter

You can get S-parameter from here.

<https://product.tdk.com/en/search/rf/rf/filter/characteristic/>

## RF Components & Modules Product Center

Attracting Tomorrow 

Visit the TDK Product Center online to find the latest datasheets and production status information, as well as selection and application guides, general technical information, environmental and material datasheets, and many other technical articles and support tools.

Web Address:

<https://product.tdk.com/info/en/products/rf/index.html>

Features / Functions:

- Datasheets & S-Parameters
- Search by Part Number
- Search by Characteristics
- Catalog
- Technical Notes
- Application Guide
- Selection Guide
- Frequently Asked Questions (FAQs)
- Sample Kits
- TDK Newsletter
- and more...

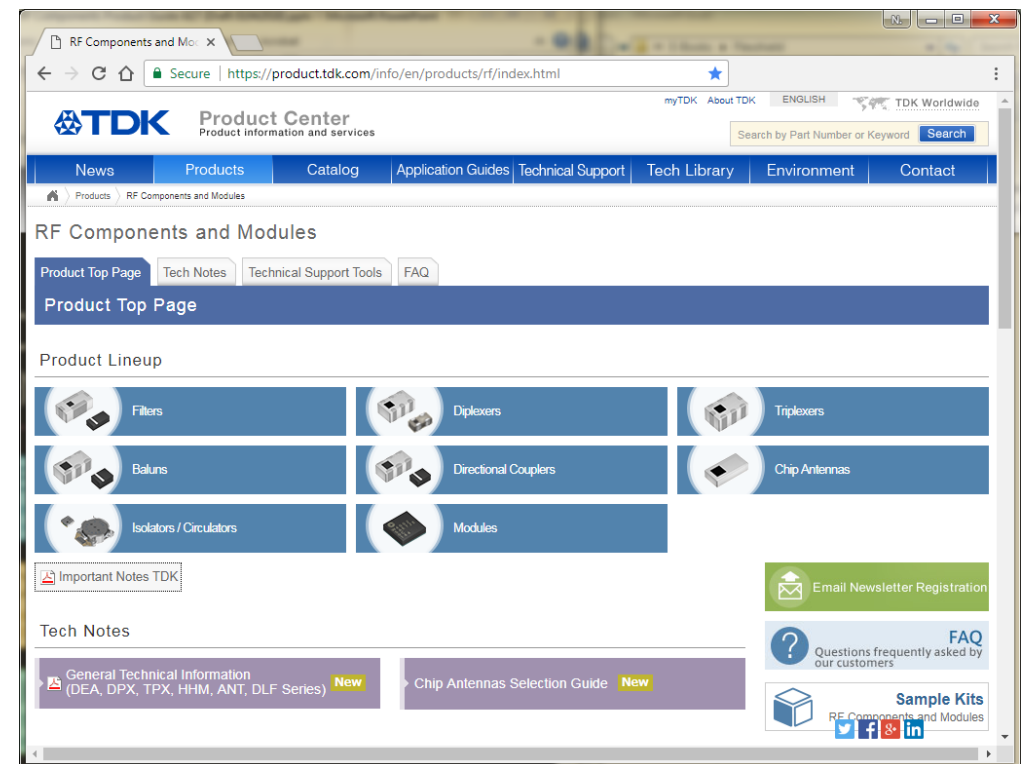

Search, compare, and review TDK RF components performance with a variety of technical support materials on TDK new enhanced web site.

But due to the sheer number of components, please contact us: [wirelessinfo@us.tdk.com](mailto:wirelessinfo@us.tdk.com)

Attracting Tomorrow



# TDK RF Product Line Summary

---

# RF Filters Product Line Summary

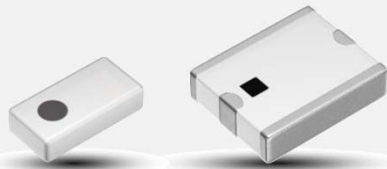

## CHIP ANTENNAS

- LTCC-based platform antennas
- Case Size: EIA 0603 ~ EIA 1008
- Frequencies: 900MHz ~ 5.95GHz
- Termination Type: STD or LGA
- Operating Temperature: -40 ~ +85°C
- Efficiency: Up to 80%
- Omni-directional & Linear Polarization

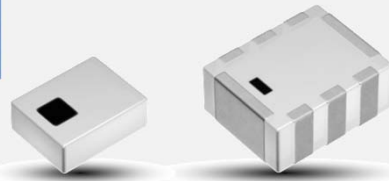

## BAND PASS FILTERS

- LTCC-based LC Filters
- Case Size: EIA 0402 ~ EIA 1008
- Frequencies: 869MHz ~ 5.95GHz
- Termination Type: STD or LGA
- Operating Temperature: -40 ~ +85°C
- Low loss and high reliability performance
- Available with integrated Balun as 2-in-1

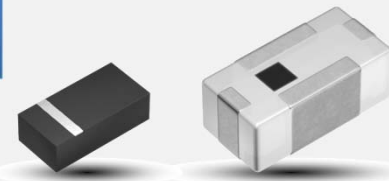

## LOW PASS FILTERS

- LTCC and Thinfilm-based LC Filters
- Case Size: EIA 0202 ~ EIA 1008
- Frequencies: ~ 5.95GHz
- Termination Type: STD or LGA
- Operating Temperature: -40 ~ +85°C
- Low loss and high reliability performance
- Available with integrated Balun as 2-in-1

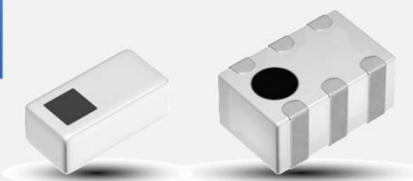

## HIGH PASS FILTERS

- LTCC-based LC Filters
- Case Size: EIA 0302 ~ EIA 0805
- Frequencies: 1710MHz ~
- Termination Type: STD or LGA
- Operating Temperature: -40 ~ +85°C
- Low loss and high reliability performance

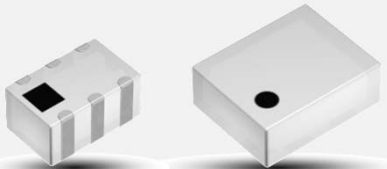

## DIPLEXERS

- LTCC-based LC Diplexers
- Case Size: EIA 0402 ~ EIA 1008
- Frequencies: 570MHz ~ 5.95GHz
- Termination Type: STD or LGA
- Operating Temperature: -40 ~ +85°C
- Low Insertion Loss
- Temperature-stable performance

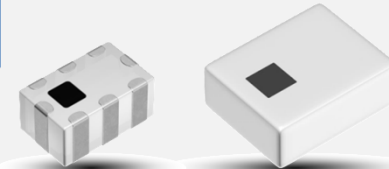

## TRIPLEXERS

- LTCC-based LC Triplexers
- Case Size: EIA 0805 ~ EIA 1210
- Frequencies: 450MHz ~ 5.95GHz
- Termination Type: STD or LGA
- Operating Temperature: -40 ~ +85°C
- Low Insertion Loss
- Temperature-stable performance

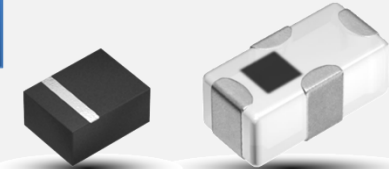

## BALUNS

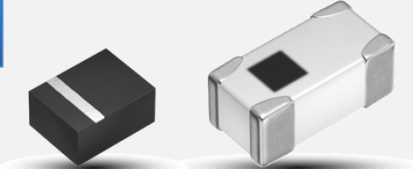

- LTCC and Thinfilm-based Baluns
- Case Size: EIA 0202 ~ EIA 0805
- Frequencies: 673MHz ~ 5.95GHz
- Termination Type: STD or LGA
- Operating Temperature: -40 ~ +85°C
- Available in 50:50, 75:50, 100:50, and 200:50 as well as chipset specific



## COUPLERS

- LTCC and Thinfilm-based Couplers
- Case Size: EIA 0202 ~ EIA 0805
- Frequencies: 450MHz ~ 5.95GHz
- Termination Type: STD or LGA
- Operating Temperature: -40 ~ +85°C
- Available with LPF in one package as well as 3dB divider & power combiner

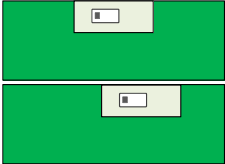
# Chip Antenna Selection Guide

CHIP ANTENNA MOUNTING GUIDELINE	APPLICATION	FREQUENCY BAND			
		Sub-GHz Band	GNSS Band	2.4GHz Band	5GHz Band
<b>PCB CENTER-EDGE</b>  Mount at center edge of PC Board (Surround by GND in 3 directions)	Single Band		<b>ANT016008LCD1575MA1</b> 1574-1576MHz / 2400-2484MHz 1.6×0.8×0.4mm	<b>ANT016008LCS2442MA1</b> 2400-2484MHz 1.6×0.8×0.4mm	<b>ANT165550ST-1003A1</b> 5150-5950MHz 1.6×0.8×0.4mm
	Dual Band		<b>ANT016008LCD1575MA1</b> 1574-1576MHz / 2400-2484MHz 1.6×0.8×0.4mm		
				<b>ANT162442DT-2001A2</b> 2400-2484MHz / 5150-5850MHz 1.6×0.8×0.4mm	
Triple Band		<b>ANT161575TT-3000A1</b> 1574-1577MHz / 2400-2484MHz / 5150-5850MHz 1.6×0.8×0.4mm			
<b>PCB CORNER</b>  Mount at corner of PC Board (Surround by GND in 1 or 2 directions)	Single Band	<b>ANT160920ST-1204A1</b> 902-930MHz 1.6×0.8×0.4mm	<b>ANT161575ST-1202A1</b> 1557-1605MHz 1.6×0.8×0.4mm	<b>ANT016008LCS2442MA2</b> 2400-2484MHz 1.6×0.8×0.4mm	<b>ANT165550ST-1003A1</b> *1 5150-5950MHz 1.6×0.8×0.4mm
	Dual Band			<b>ANT162442DT-2200A1</b> 2400-2484MHz / 5150-5850MHz 1.6×0.8×0.4mm	
	Triple Band		<b>ANT025020LCT1575MA1</b> 1574-1577MHz / 2400-2484MHz / 5150-5850MHz 2.5×2.0×0.6mm		

\*1 : Recommended for mounting near the corner of PC Board

# Circulators/Isolators Product Line Summary

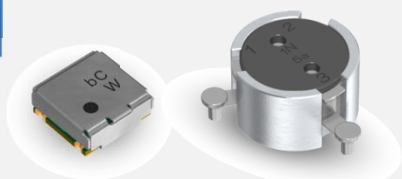

## CIRCULATORS

- Cylindrical Type:  $\varnothing$ 10m ~  $\varnothing$ 24m
- Square Type: 5x5mm
- Frequencies: 700MHz ~ 6GHz
- Handling Power: 5W ~ 110W
- Operating Temperature: -35 ~ +85°C
- Low Insertion Loss
- Customizable & available CW or CCW

Type	Available Frequency Range	Power Handling Capability (W)	Isolation (dB) Min	Insertion Loss (dB) Max	Case Size (mm) L x W x Tmax	Product Series
Square Type	700MHz – 2,700MHz	5	11 – 15	0.60 – 1.20	5 x 5 x 2.2	<b>CU4S0506*C</b>
	2,000MHz – 2,700MHz	50	20	0.30 – 0.35	$\varnothing$ 10 x 7.0	<b>CU1S1055*C</b>
Cylindrical Type	1,800MHz – 6,000MHz	20 / 50	18 – 22	0.25 – 0.50	$\varnothing$ 11 x 7.0	<b>CU1S1065*C</b>
	1,800MHz – 3,800MHz	20	18 – 23	0.30	$\varnothing$ 12 x 7.0	<b>CU1S1281*C</b>
	1,500MHz – 2,700MHz	100	20	0.30	$\varnothing$ 19 x 8.5	<b>CU1S1941*C</b>
	700MHz – 2,200MHz	100	18 – 20	0.25 – 0.30	$\varnothing$ 25 x 10.5	<b>CU1S2403*C</b>

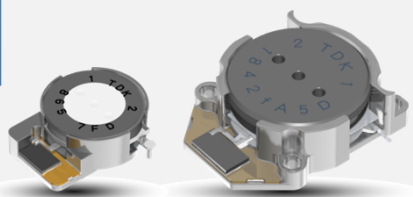

## ISOLATORS

- Cylindrical Type:  $\varnothing$ 22m ~  $\varnothing$ 25m
- Square Type: 4x4mm ~ 10x10mm
- Frequencies: 700MHz ~ 3.6GHz
- Handling Power: 2.5W ~ 150W
- Operating Temperature: -35 ~ +85°C
- Low Insertion Loss
- Customizable & available CW or CCW

Type	Available Frequency Range	Power Handling Capability (W)	Isolation (dB) Min	Insertion Loss (dB) Max	Case Size (mm) L x W x Tmax	Product Series
Square Type	700MHz – 2,700MHz	2.5	11 – 15	0.60 – 1.10	4 x 4 x 2.0	<b>CU4S0401*T</b>
	700MHz – 3,600MHz	5	10 – 15	0.70 – 1.20	5 x 5 x 2.2	<b>CU4S0506*T</b>
	700MHz – 2,700MHz	10	8.0 – 15	0.65 – 1.20	7 x 7 x 3.0	<b>CU4S0701*T</b>
	700MHz – 2,200MHz	20	10 – 15	0.60 – 0.95	10 x 10 x 4.2	<b>CU4S1001*T</b>
Cylindrical Type	700MHz – 2,700MHz	110	21	0.25	$\varnothing$ 22 x 10.5	<b>CU1S2252*T</b>
	700MHz – 2,200MHz	150	21 – 25	0.25	$\varnothing$ 25 x 9.5	<b>CU1L2581*T</b>

# Flexield Product Line Summary

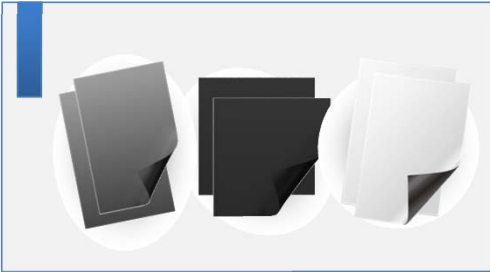

## FEATURES

- Flexible & thin noise suppression sheets
- Thickness: 25 $\mu$ m ~ 200 $\mu$ m
- Permeability@1MHz: 100 ~ 220
- Frequencies: 0.5MHz to 6GHz
- Up to 1M $\Omega$ /sq min. Surface Resistivity

## APPLICATIONS

- Suppression of noise emitted from ICs & flexible cables
- Protection of circuits from noise emission
- Improving performance in RFID reader/writers & NFC
- Integrate IC cards/tags with metal
- Reduce noise in Automotive HUD, Camera, Harness, etc.

### IFL10M | THIN TYPE



FEATURE	THICKNESS	TDK PART NUMBER
$\mu$ @1MHz > 120	0.025 mm	IFL10M-025NB300X200
	0.050 mm	IFL10M-050NB300X200
	0.100 mm	IFL10M-100NB300X200
	0.200 mm	IFL10M-200ND300X200

### IFL04 | For NFC & RFID



FEATURE	THICKNESS	TDK PART NUMBER
Low Loss $\mu'$ =45 & $\mu''$ =1.3 @13.56MHz	0.050 mm	IFL4-050NB300X200
	0.100 mm	IFL4-100NB300X200
	0.200 mm	IFL4-200ND300X200

### IFL12 | HIGH PERMEABILITY



FEATURE	THICKNESS	TDK PART NUMBER
$\mu$ @1MHz > 180	0.050 mm	IFL12-050NB300X200
	0.100 mm	IFL12-100NB300X200
	0.200 mm	IFL12-200NB300X200

### IFL16 & IFM10M | HYBRID TYPE



FEATURE	THICKNESS	TDK PART NUMBER
$\mu$ @1MHz > 220 w/ ALPET (30 $\mu$ m)	0.030 mm	IFL16-030EB300X200
		IFL16-030GB300X200
$\mu$ @1MHz > 120	0.025 mm	IFM10M-025BB300X200

### IFL16 | SUPER HIGH PERMEABILITY



FEATURE	THICKNESS	TDK PART NUMBER
$\mu$ @1MHz > 220	0.030 mm	IFL16-030NB300X200
	0.050 mm	IFL16-050NB300X200
	0.100 mm	IFL16-100NB300X200

### IFF08 | HEAT-RESISTANT TYPE



FEATURE	THICKNESS	TDK PART NUMBER
Max Operating Temperature 125°C	0.050 mm	IFF08-050ND300X200
	0.100 mm	IFF08-100ND300X200

# Flexield for EMC | ILF/IFM/IFF Series

## Noise Suppression

- Noise suppression in the IC peripheral circuit of the main circuit board
- Noise suppression for flexible cables
- Reduce EMI level at connector
- Noise suppression for external cables

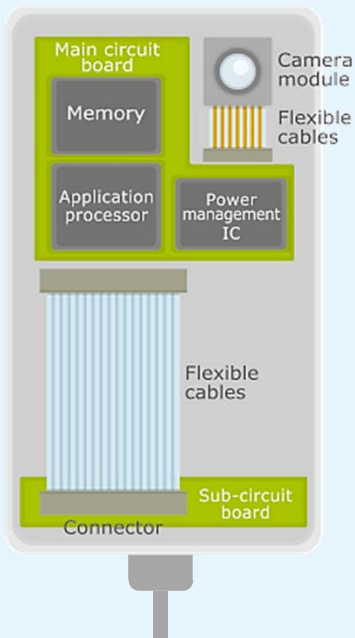

## Reflected Noise Absorption

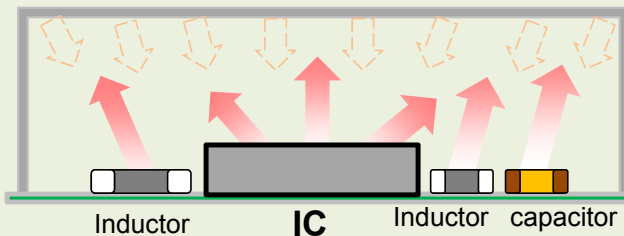

- IC, inductor capacitor, etc. generate EMI noise and is reflect by metal cover
- >> Increase noise level inside of metal cover

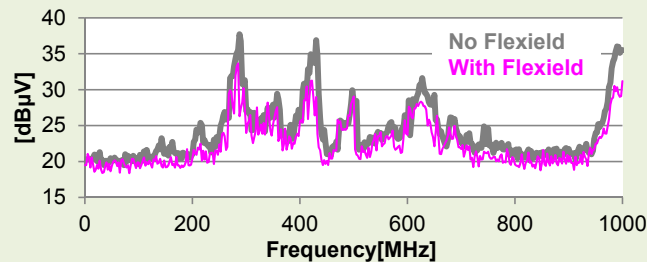
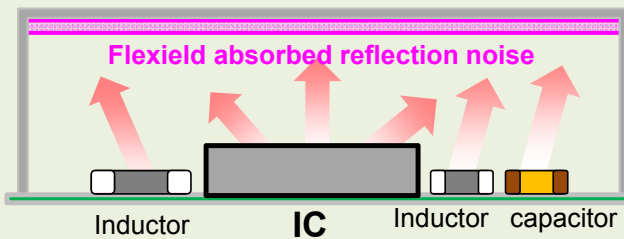

## ESD Suppression

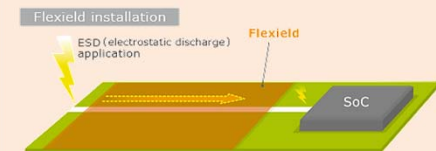
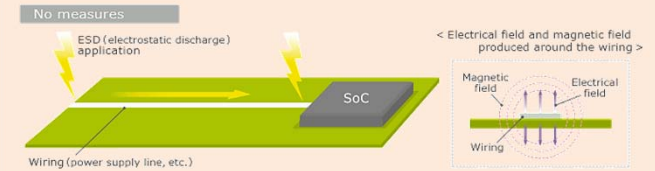

Measured waveform during the ESD application test

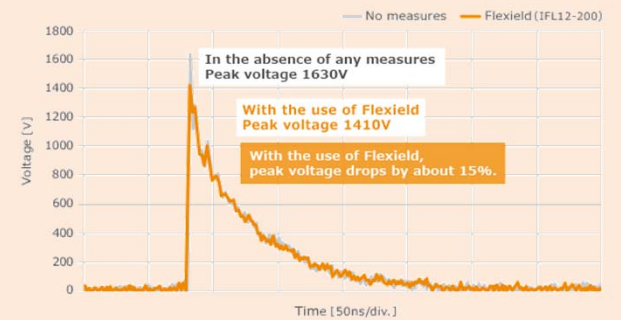

< Measurement conditions >  
 • IEC61000-4-2 • Level1 (ESD voltage 8kV) • Human body model • Contact discharge

# Flexield For NFC | IFL04 Series

## Without Magnetic Sheet

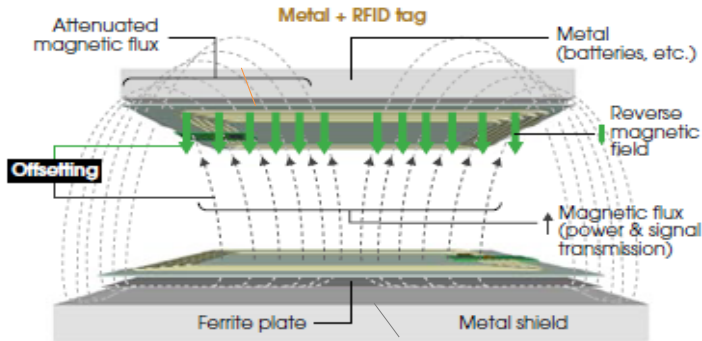

Metal objects interfere with magnetic flux

## With Magnetic Sheet

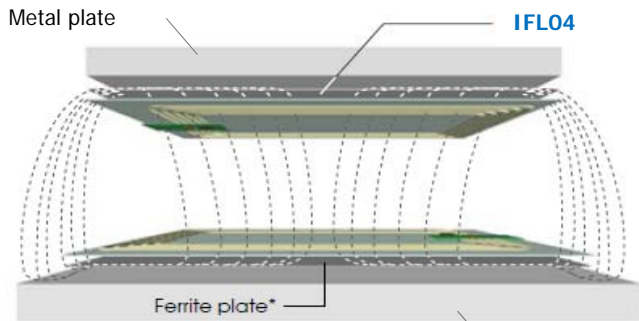

Flexield remove disturbance allow for better reception

## FEATURES

- High permeability, low magnetic loss @13.56MHz
- Thin & Flexible: can be processed into various shape and size
- Available in sheets or rolls

## APPLICATIONS

- For improving reception performance in NFC/RFID systems
- Integrate IC cards with metal (e.g. credit cards, gift cards, etc.)
- Integrate IC tags with metal (e.g. security access cards, etc.)
- Improve antenna reception sensitivity

## RELATIVE PERMEABILITY

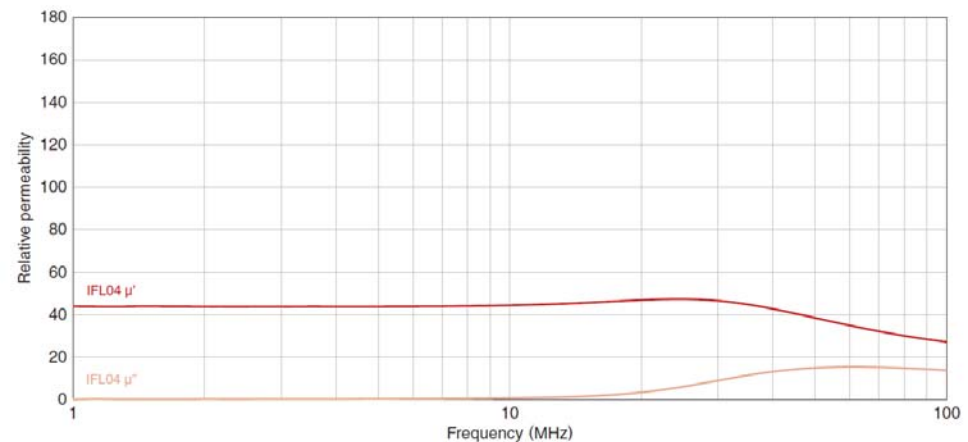

# Flexield Selection Guide

Pass Band Characteristics (dB)

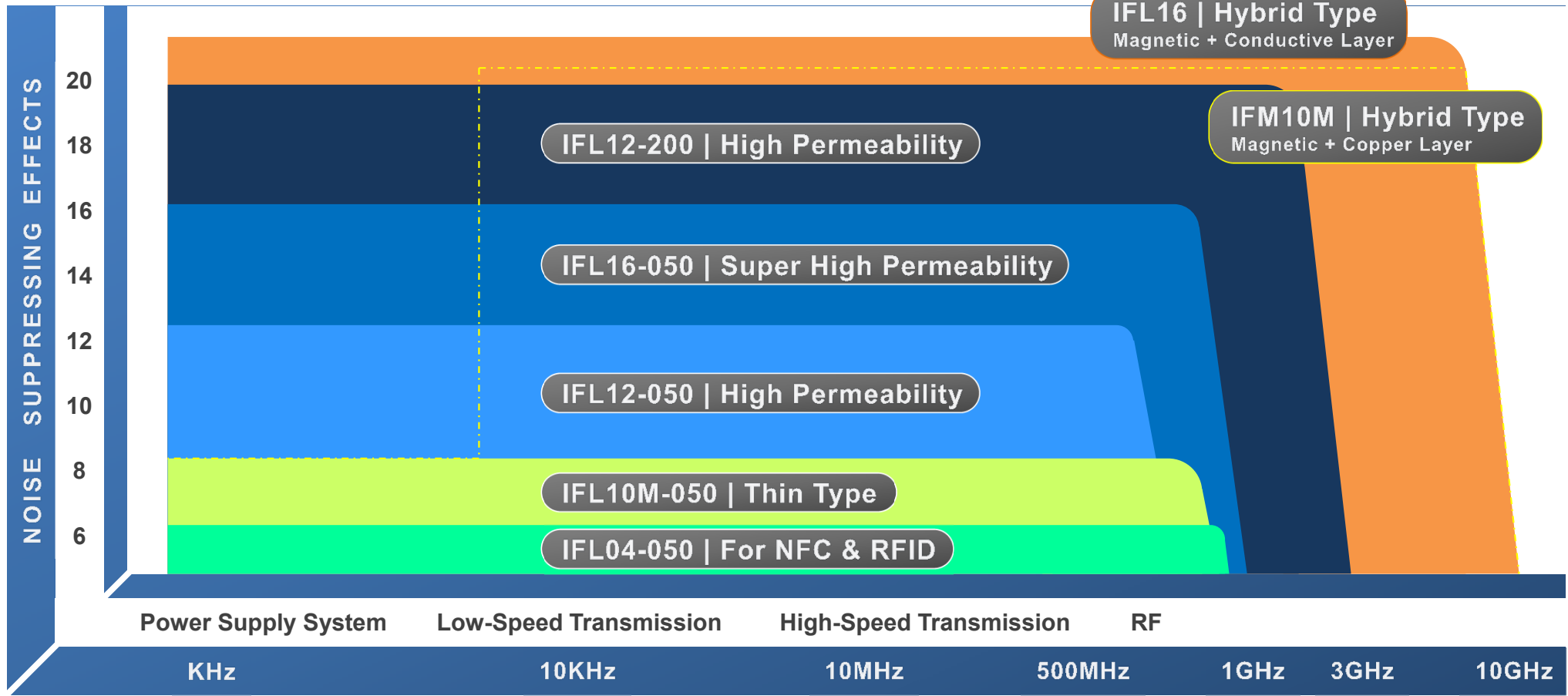

Attracting Tomorrow



# TDK RF Design Support & Technical Tools

---

# RF Filters Product Line Summary

## E-Books & Promotional Materials

- **General E-Books**
  - ✓ WLAN/BT
  - ✓ Cellular/LTE
  - ✓ Modules
- **Reference Design E-Books**
  - ✓ QCOM WTR 2K/3K/4K
  - ✓ QCOM WTR 5K/6K/8K/SDR855
  - ✓ MediaTek MT6K
  - ✓ Intel Smarti4/5/5S
- **Product Overview Presentations**
  - ✓ LTCC & TFS General Presentation
  - ✓ LTCC & TFS Standard Item List
  - ✓ Diplexer Selection Guide
  - ✓ Triplexer Selection Guide
  - ✓ Balun Selection Guide
  - ✓ Coupler Comparison Chart
  - ✓ Chip Antenna Overview & Services
  - ✓ Isolator/Circulator Overview
  - ✓ Connectivity (WLAN/BT)
  - ✓ Cellular (General)
  - ✓ 5G (Sub 6GHz) RF Components
  - ✓ RF Components for Automotive



## Samples, Evaluation Boards, & Sample Book

Available:

- Thru Board
- Blank Test Board
- Test Board with Samples Mounted
- Bulk Samples
- Sample Book:
  - WLAN / BT
  - Cellular / LTE
  - Modules
  - Flexfield
  - Chipset Specific

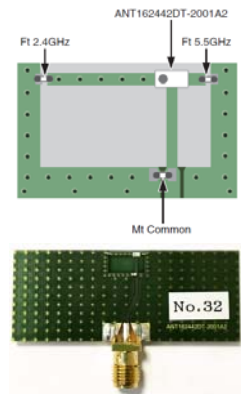
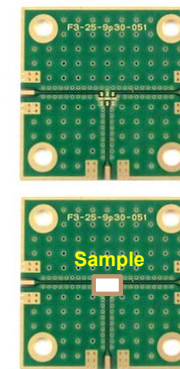

## RF Components Product Guide

**NEW!**

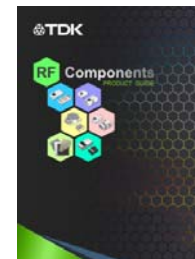

### Contents:

- Product Line Summary / Part Number Decipher
- Series Overview for All RF Products
- Application Guide
  - Cellular / Connectivity / Automotive / Infrastructure
- Design Support Information

**AVAILABLE FROM YOUR LOCAL SALES REPS!**

# Summary

---

- RF components are sensitive to GND conditions
  - Please follow our pad layout recommendation in the datasheet
  - By using shielded type products, you can disregard shielding can impact
  - You can also request technical support from our FAE team FOC
- Antenna performance is affected by GND size and antenna location
  - TDK FAE can provide technical support for antenna layout design FOC
- You can find technical support on our new enhanced web site
  - You can simulate our antenna & design the PCB layout
  - You can evaluate TDK RF component performance with s-parameter
- ◆ TDK Website <https://product.tdk.com/info/en/products/rf/index.html>
- ◆ Wirelessinfo@us.tdk.com

