

Main Product Characteristics

$V_{(BR)DSS}$	650V
$R_{DS(ON)}$	2.3Ω (Typ.)
I_D	4A

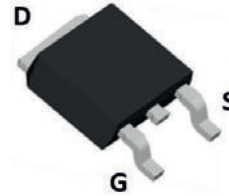

TO-252 (DPAK)

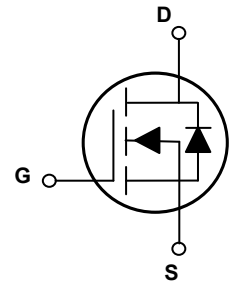

Schematic Diagram

Features and Benefits

- Advanced MOSFET process technology
- Ideal for high efficiency switched mode power supplies
- Low on-resistance with low gate charge
- Fast switching and reverse body recovery



Description

The GSFD4N65 utilizes the latest techniques to achieve high cell density and low on-resistance. These features make this device extremely efficient and reliable for use in high efficiency switch mode power supplies and a wide variety of other applications.

Absolute Maximum Ratings ($T_C=25^\circ\text{C}$ unless otherwise specified)

Parameter	Symbol	Max.	Unit
Drain-Source Voltage	V_{DS}	650	V
Gate-Source Voltage	V_{GS}	±30	V
Continuous Drain Current, @ Steady-State ($T_C=25^\circ\text{C}$)	I_D	4	A
Continuous Drain Current, @ Steady-State ($T_C=100^\circ\text{C}$)		2.5	A
Pulsed Drain Current ¹	I_{DM}	16	A
Single Pulsed Avalanche Energy ²	E_{AS}	215	mJ
Power Dissipation ($T_C=25^\circ\text{C}$)	P_D	77	W
Thermal Resistance, Junction to Case	$R_{\theta JC}$	1.62	$^\circ\text{C/W}$
Thermal Resistance, Junction to Ambient	$R_{\theta JA}$	110	$^\circ\text{C/W}$
Operating and Storage Temperature Range	T_J/T_{STG}	-55 to +150	$^\circ\text{C}$

Electrical Characteristics ($T_C=25^\circ\text{C}$ unless otherwise specified)

Parameter	Symbol	Test Condition	Min.	Typ.	Max.	Unit
On / Off Characteristics						
Drain-Source Breakdown Voltage	$V_{(BR)DSS}$	$V_{GS}=0V, I_D=250\mu A$	650	-	-	V
Zero Gate Voltage Drain Current	I_{DSS}	$V_{DS}=650V, V_{GS}=0V, T_J=25^\circ\text{C}$	-	-	1	μA
Gate to Body Leakage Current	I_{GSS}	$V_{GS}=\pm 30V$	-	-	± 100	nA
Gate Threshold Voltage	$V_{GS(th)}$	$V_{DS}=V_{GS}, I_D=250\mu A$	2	-	4	V
Static Drain-Source On-Resistance ³	$R_{DS(ON)}$	$V_{GS}=10V, I_D=2A$	-	2.3	2.7	Ω
Dynamic and Switching Characteristics						
Input Capacitance	C_{iss}	$V_{DS}=25V, V_{GS}=0V, F=1.0\text{MHz}$	-	430	-	pF
Output Capacitance	C_{oss}		-	55	-	pF
Reverse Transfer Capacitance	C_{rss}		-	4.1	-	pF
Total Gate Charge	Q_g	$V_{DD}=520V, I_D=4A, V_{GS}=10V$	-	12.5	-	nC
Gate-Source Charge	Q_{gs}		-	2.74	-	nC
Gate-Drain ("Miller") Charge	Q_{gd}		-	6.31	-	nC
Turn-On Delay Time	$t_{d(on)}$	$V_{DD}=325V, I_D=4A, R_G=25\Omega, V_{GS}=10V$	-	9.93	-	nS
Turn-On Rise Time	t_r		-	25.6	-	nS
Turn-Off Delay Time	$t_{d(off)}$		-	27.6	-	nS
Turn-Off Fall Time	t_f		-	25.6	-	nS
Source-Drain Ratings and Characteristics						
Maximum Continuous Drain to Source Diode Forward Current	I_S	MOSFET symbol showing the integral reverse p-n junction diode.	-	-	4	A
Maximum Pulsed Drain to Source Diode Forward Current	I_{SM}		-	-	16	A
Drain to Source Diode Forward Voltage	V_{SD}	$V_{GS}=0V, I_{SD}=4A, T_J=25^\circ\text{C}$	-	-	1.4	V
Reverse Recovery Time	t_{rr}	$V_{GS}=0V, I_S=4A, di/dt=100A/\mu S$	-	450	-	nS
Reverse Recovery Charge	Q_{rr}		-	1.87	-	μC

Note:

1. Repetitive rating: pulse width limited by maximum junction temperature.
2. $I_{AS}=3.6A, L=30\text{mH}, V_{DD}=100V, R_G=25\Omega$, starting $T_J=25^\circ\text{C}$.
3. Pulse test: pulse width $\leq 300\mu S$, duty cycle $\leq 1\%$.

Typical Electrical and Thermal Characteristic Curves

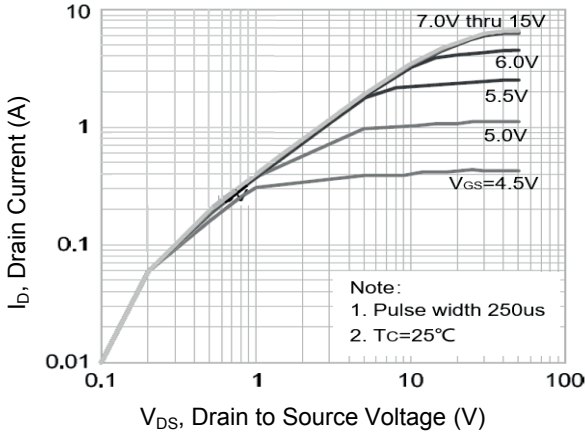

Figure 1. Output Characteristics

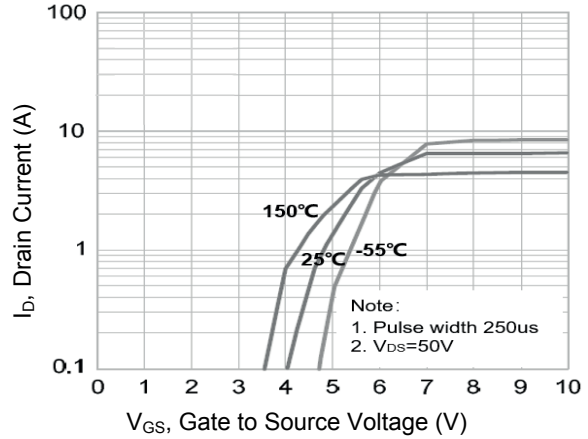

Figure 2. Transfer Characteristics

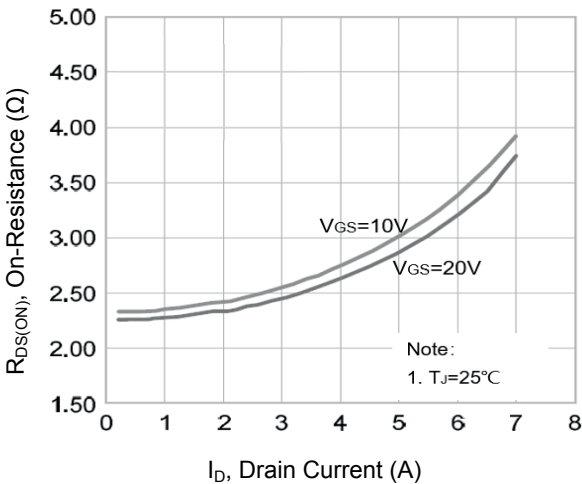

Figure 3. $R_{DS(ON)}$ vs. Drain Current

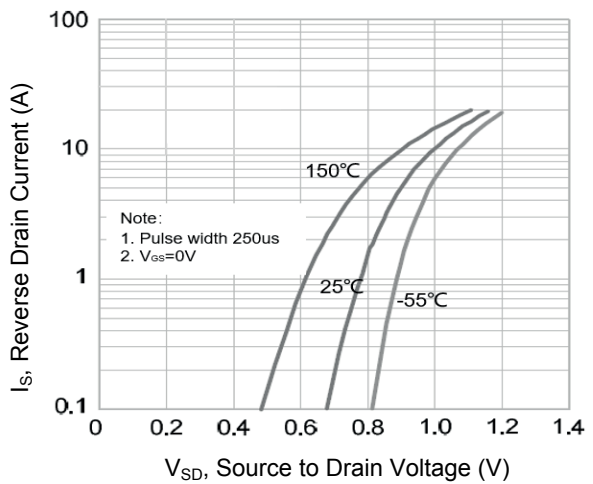

Figure 4. Body Diode Characteristics

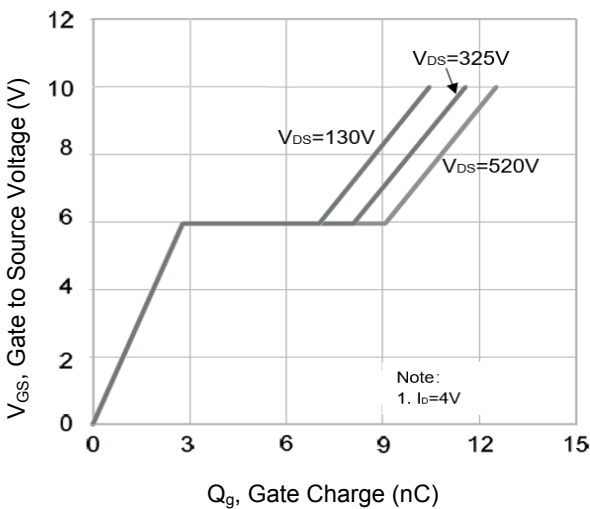

Figure 5. Gate Charge

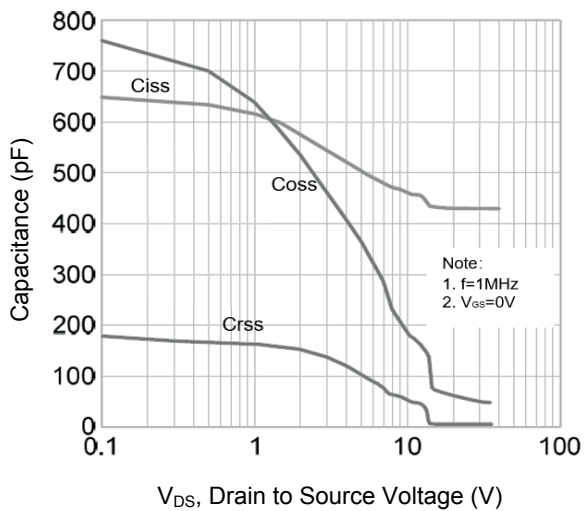

Figure 6. Capacitance Characteristics

Typical Electrical and Thermal Characteristic Curves

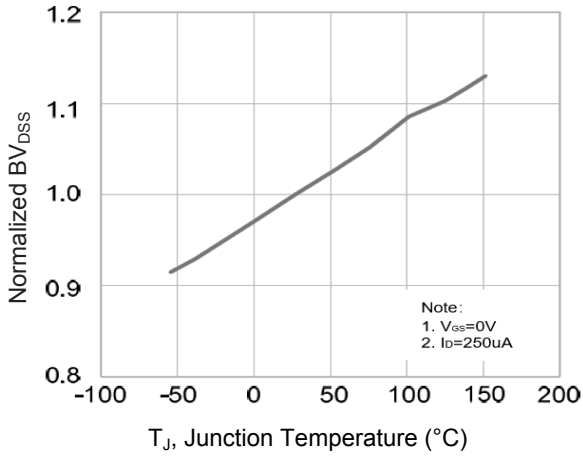

Figure 7. Normalized BV_{DSS} vs. T_J

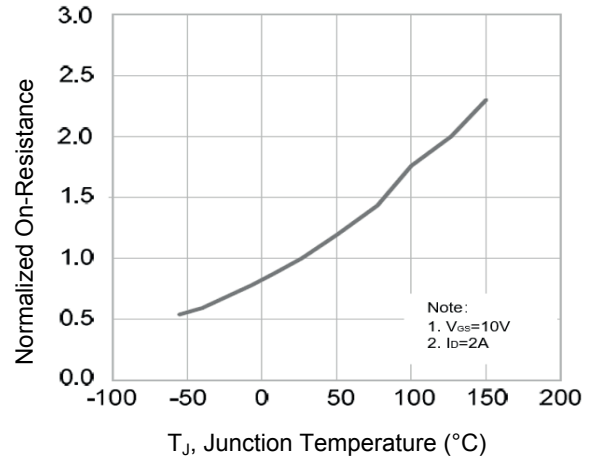

Figure 8. Normalized $R_{DS(ON)}$ vs. T_J

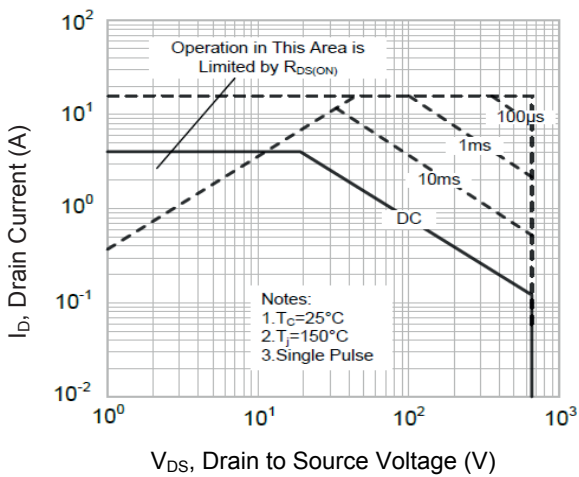

Figure 9. Safe Operation Area

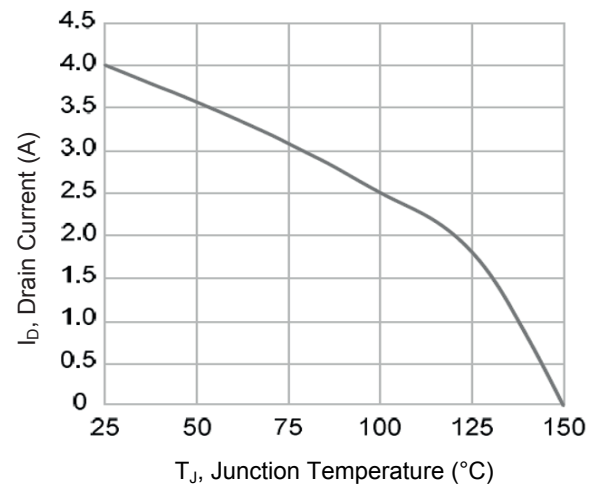
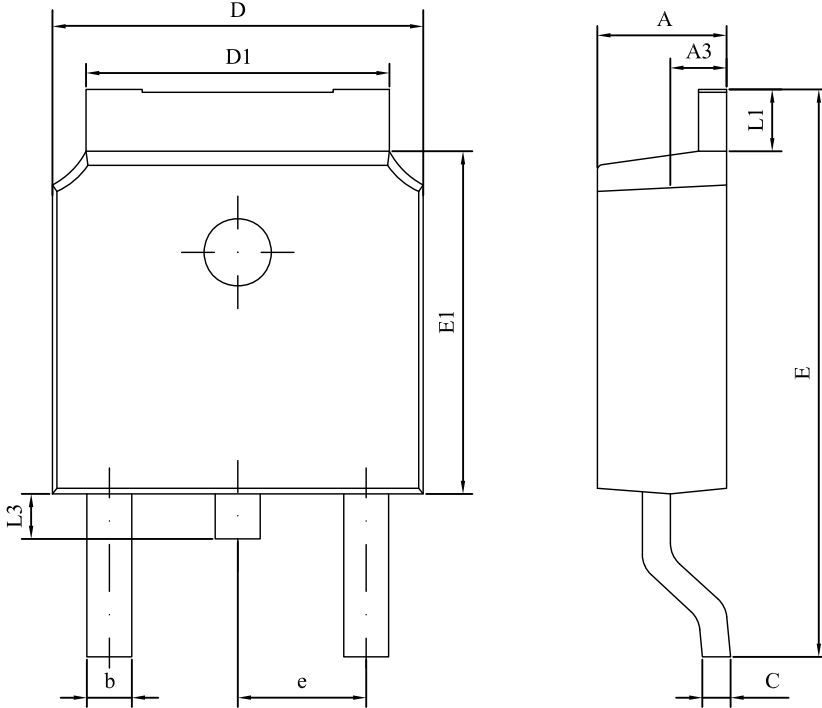

Figure 10. Current De-Rating

Package Outline Dimensions TO-252(DPAK)



Symbol	Dimensions In Millimeters		Dimensions In Inches	
	Min.	Max.	Min.	Max.
A	2.15	2.40	0.085	0.094
A3	0.90	1.10	0.035	0.043
b	0.50	0.90	0.020	0.035
C	0.40	0.65	0.016	0.026
D	6.30	6.90	0.248	0.272
D1	4.95	5.50	0.195	0.217
E	9.40	10.41	0.370	0.410
E1	5.90	6.30	0.232	0.248
e	2.286 BSC		0.090 BSC	
L1	0.89	1.27	0.035	0.050
L3	0.60	1.10	0.024	0.043

Order Information

Device	Package	Marking	Carrier	Quantity
GSFD4N65	TO-252 (DPAK)	D4N65	Tape & Reel	2,500 Pcs / Reel

For more information, please contact us at: inquiry@goodarksemi.com