

Current 9 Click



PID: MIKROE-5319

Current 9 Click is a compact add-on board providing a precise and accurate current sensing solution. This board features the [CT415-HSN830DR](#), high-bandwidth and ultra-low-noise XtremeSense® TMR current sensor designed for the current range up to 30A from [Crocus Technology](#). This sensor also features an integrated current-carrying conductor which handles rated current and generates a current measurement as a linear analog output voltage, accomplishing a total output error of about $\pm 1\%$ full-scale. After that, the user is allowed to process the output voltage in analog or digital form. This Click board™ is ideal for high-accuracy current measurements for many consumer, enterprise, and industrial applications.

Current 9 Click is supported by a [mikroSDK](#) compliant library, which includes functions that simplify software development. This [Click board™](#) comes as a fully tested product, ready to be used on a system equipped with the [mikroBUS™](#) socket.

DO NOT TOUCH THE BOARD WHILE THE LOAD IS CONNECTED!

Note: This Click board™ needs to be used by trained personnel only while applying high voltages. Special care should be taken when working with hazardous voltage levels.

How does it work?

Current 9 Click as its foundation uses the CT415-HSN830DR, an XtremeSense® TMR current

Mikroe produces entire development toolchains for all major microcontroller architectures.

Committed to excellency, we are dedicated to helping engineers bring the project development up to speed and achieve outstanding results.



ISO 27001: 2013 certification of informational security management system.
 ISO 14001: 2015 certification of environmental management system.
 OHSAS 18001: 2008 certification of occupational health and safety management system.



ISO 9001: 2015 certification of quality management system (QMS).

sensor providing high-accuracy current measurements from Crocus Technology. The CT415-HSN830DR comes with an integrated current carrying conductor (CCC) that handles current from 0A up to 30A. It has high sensitivity and a wide dynamic range with excellent accuracy (low total output error) across temperature range from -40°C to +85°C making it suitable for many consumer, enterprise, and industrial applications.

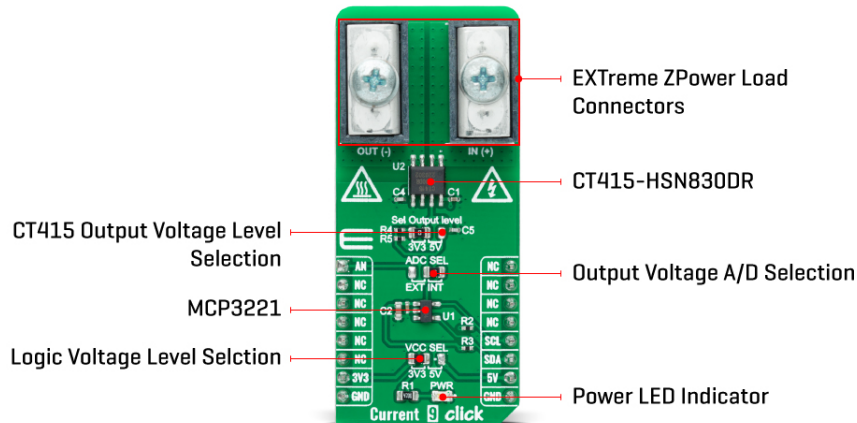

When current flows through the CCC, the XtremeSense® TMR sensors inside the chip sense the field, generating a differential voltage signal that goes through the analog front-end to output a current measurement with less than $\pm 1\%$ full-scale total output error. The CT415-HSN830DR is designed to enable a fast response time for the current measurement. In addition, the user is provided with the option of selecting the output voltage level of the sensor performed by the onboard SMD jumper by populating it to an appropriate position marked as 3V3 or 5V. Even with high bandwidth of 1MHz, the CT415 consumes minimal power.

The output signal of the CT415-HSN830DR can be converted to a digital value using MCP3221, a successive approximation A/D converter with a 12-bit resolution from Microchip using a 2-wire I2C compatible interface, or can be sent directly to an analog pin of the mikroBUS™ socket labeled as AN. Selection can be performed by onboard SMD jumper labeled as ADC SEL, placing it to an appropriate position marked as EXT and INT.

Also, this Click board™ should be connected in series with the load. The current is measured by two onboard terminal connectors, one terminal block for the positive and the other for the negative current input.

This Click board™ can operate with both 3.3V and 5V logic voltage levels selected via the VCC SEL jumper. This way, it is allowed for both 3.3V and 5V capable MCUs to use the communication lines properly. However, the Click board™ comes equipped with a library containing easy-to-use functions and an example code that can be used, as a reference, for further development.

Specifications

Type	Current sensor, Measurements
Applications	Can be used for many consumer, enterprise, and industrial applications
On-board modules	CT415-HSN830DR - XtremeSense® TMR

Mikroe produces entire development toolchains for all major microcontroller architectures.

Committed to excellency, we are dedicated to helping engineers bring the project development up to speed and achieve outstanding results.



ISO 27001: 2013 certification of informational security management system.
 ISO 14001: 2015 certification of environmental management system.
 OHSAS 18001: 2008 certification of occupational health and safety management system.



ISO 9001: 2015 certification of quality management system (QMS).

	current sensor from Crocus Technology
Key Features	Low power consumption, integrated current carrying conductor, low total error output, high bandwidth, fast response time, high accuracy and precision, possibility of signal processing in analog and digital form, and more
Interface	Analog, I2C
Feature	No ClickID
Compatibility	mikroBUS™
Click board size	L (57.15 x 25.4 mm)
Input Voltage	3.3V or 5V

Pinout diagram

This table shows how the pinout on Current 9 Click corresponds to the pinout on the mikroBUS™ socket (the latter shown in the two middle columns).

Notes	Pin					Pin	Notes
Analog Signal	AN	1	AN	PWM	16	NC	
	NC	2	RST	INT	15	NC	
	NC	3	CS	RX	14	NC	
	NC	4	SCK	TX	13	NC	
	NC	5	MISO	SCL	12	SCL	I2C Clock
	NC	6	MOSI	SDA	11	SDA	I2C Data
Power Supply	3.3V	7	3.3V	5V	10	5V	Power Supply
Ground	GND	8	GND	GND	9	GND	Ground

Onboard settings and indicators

Label	Name	Default	Description
LD1	PWR	-	Power LED Indicator
JP1	OUT SEL	Left	CT415 Output Voltage Level Selection 3V3/5V: Left position 3V3, Right position 5V
JP2	VCC SEL	Left	Logic Level Voltage Selection 3V3/5V: Left position 3V3, Right position 5V
JP3	ADC SEL	Right	Output Voltage A/D Selection EXT/INT: Left position EXT, Right position INT

Current 9 Click electrical specifications

Description	Min	Typ	Max	Unit
Supply Voltage	3.3	-	5	V

Mikroe produces entire development toolchains for all major microcontroller architectures.

Committed to excellency, we are dedicated to helping engineers bring the project development up to speed and achieve outstanding results.



ISO 27001: 2013 certification of informational security management system.
ISO 14001: 2015 certification of environmental management system.
OHSAS 18001: 2008 certification of occupational health and safety management system.



ISO 9001: 2015 certification of quality management system (QMS).

Current Measurement Range	0	-	30	A
---------------------------	---	---	----	---

Software Support

We provide a library for the Current 9 Click as well as a demo application (example), developed using MikroElektronika [compilers](#). The demo can run on all the main MikroElektronika [development boards](#).

Package can be downloaded/installed directly from NECTO Studio Package Manager(recommended way), downloaded from our [LibStock™](#) or found on [Mikroe github account](#).

Library Description

This library contains API for Current 9 Click driver.

Key functions

- `current9_read_voltage` This function reads raw ADC value and converts it to proportional voltage level.
- `current9_read_current` This function reads the input current level [A] based on `@b CURRENT9_NUM_CONVERSIONS` of voltage measurements.
- `current9_set_vref` This function sets the voltage reference for Current 9 click driver.

Example Description

This example demonstrates the use of Current 9 Click board™ by reading and displaying the input current measurements.

The full application code, and ready to use projects can be installed directly from NECTO Studio Package Manager(recommended way), downloaded from our [LibStock™](#) or found on [Mikroe github account](#).

Other Mikroe Libraries used in the example:

- MikroSDK.Board
- MikroSDK.Log
- Click.Current9

Additional notes and informations

Depending on the development board you are using, you may need [USB UART click](#), [USB UART 2 Click](#) or [RS232 Click](#) to connect to your PC, for development systems with no UART to USB interface available on the board. UART terminal is available in all MikroElektronika [compilers](#).

mikroSDK

This Click board™ is supported with [mikroSDK](#) - MikroElektronika Software Development Kit. To ensure proper operation of mikroSDK compliant Click board™ demo applications, mikroSDK

Mikroe produces entire development toolchains for all major microcontroller architectures.

Committed to excellency, we are dedicated to helping engineers bring the project development up to speed and achieve outstanding results.



ISO 27001: 2013 certification of informational security management system.
 ISO 14001: 2015 certification of environmental management system.
 OHSAS 18001: 2008 certification of occupational health and safety management system.



ISO 9001: 2015 certification of quality management system (QMS).

should be downloaded from the [LibStock](#) and installed for the compiler you are using.

For more information about mikroSDK, visit the [official page](#).

Resources

[mikroBUS™](#)

[mikroSDK](#)

[Click board™ Catalog](#)

[Click boards™](#)

Downloads

[MCP3221 datasheet](#)

[Current 9 click 2D and 3D files](#)

[Current 9 click schematic](#)

[Current 9 click example on Libstock](#)

[CT415 datasheet](#)

Mikroe produces entire development toolchains for all major microcontroller architectures.

Committed to excellency, we are dedicated to helping engineers bring the project development up to speed and achieve outstanding results.



ISO 27001: 2013 certification of informational security management system.
ISO 14001: 2015 certification of environmental management system.
OHSAS 18001: 2008 certification of occupational health and safety management system.



ISO 9001: 2015 certification of quality management system (QMS).