



昆山海旭科技电子有限公司

Kunshan Haixu Electronic Technology Co. Ltd

样品承认书

Specification For Approval

客户名称 Customer Name	
品名 Variety	喇叭
型号 Part No	SPK-2848-0.5W8Ω
客户型号 The customer Part No	
样品日期 Model Date	

客户承认签署

签定结果:		
核准/ <i>Approved:</i>	审核/ <i>Checked:</i>	经办/ <i>Designed:</i>

海旭确认签署

核准/ <i>Approved:</i>	审核/ <i>Checked:</i>	经办/ <i>Designed:</i>
丁爱勇	黄锡梅	梁嘉敏

承认后请签回一份! *Thank you very much!*

公司地址: 广东省佛山市顺德区容桂社区细滘路 81 号中建创科园 C2 栋 7 楼
Email: ZShaixu@163.com Web: http://www.haixucn.com/

part No	SPK-2848-0.5W8Ω	Page	1/3
---------	-----------------	------	-----

1. Normal Specification (常规规格):

NO 编号	ITEM (项目)	SPECIFICATION (规格)
1	Size 尺寸	Φ28*4.8H mm
2	Operating Temperature (°C) 工作温度	-20~+60

2. Electrical Specification (电气规格)

1	Impedance 额定阻抗	8· 15% ohm At 1000Hz/1v.
2	Lower Resonant Frequency 最低共振频率 (Fo)	530Hz±20% At1.0V
3	Output Sound Pressure Level (S.P.L) 灵敏度	93· 3db/1.0Watt0.1Meter.AverageAt600,800,1000,1200Hz.Measurement Method Shown In 。
4	Rating Power 额定功率	Normal: 0.5W Maximum: 1W.
5	Response 频率范围	FO~20,000Hz.Average SPL±10db. Shown In 。
6	Distortion 失真率	5% Maximum At 1000Hz 0.5W.
7	Buzz rattles 异常性	Must de normal 1.0V sine wave between.
8	Polarity 极性	When a positive D.C voltage is applied to the terminal marked(+)or red The diaphragm should move to the front.
9	Terminal strength 接线架结合性能试验	Capable of withstand a500g load fo3sec.Without resulting in any damage Or rejection.
10	Terminal soldering test 焊接试验	Speaker shall continue to operate after 10sec,stabilization test conditionsuppling lead wire anre and solder on the terminal board and maiming for 2seconds at temperature of 290-320· C by andiron.
11	Operating test: 纯音检听	Must de normal at program source 0.5W
12	Environmental Protection Regulation	ROHS

3. Reliability Test (可靠性试验)

1	High Test 高温试验	Keep(96)hours at +70°C±2°C then removal back to normal Temperature for 1 hours.
2	Low temperature test 低温试验	Keep(96)hours at -25°C±2°C then removal back to normal Temperature for 1 hours.
3	Temperature shock test 耐温试验	Low temperature: -25°C±2°C high temperature: +70°C±2°C Cycle: 1 hour each temperature. And then removal back to normal temperature for 1 hour.
4	Humidity test 湿热试验	Keep(96)hours at 90~95%. +40°C±2°C then removal back to normal Temperature for 6 hours.
5	Load Test 连续负荷试验	Shall be normal after test at white noise source(1w).(24) hours.
6	Operation Test 动作测试	Input power 0.3w sine wave input 1v Must Be Normal
7	Vibration Test 振动试验	F=10~55HZ amplitude: 1.5mm Test Direction is x,y,z 2H/each.
8	Drop Test 跌落试验	Drop a speaker contained in normal box into aboard 5mm thick 10 times from a height of 0.75m and then should satisfy the test described test item # 1.
9	Insulation Resistance 绝缘阻抗试验	More than 1mΩ 加直流 100V±10%。
10	Cold hot circulation 冷热循环	70°C±1°C/0.5h→20°C/0.5h→-25°C/0.5h→20°C/0.5h 10 cycles and then on 20°C 3 hours.

4. Frequency Response curve (频率曲线图):

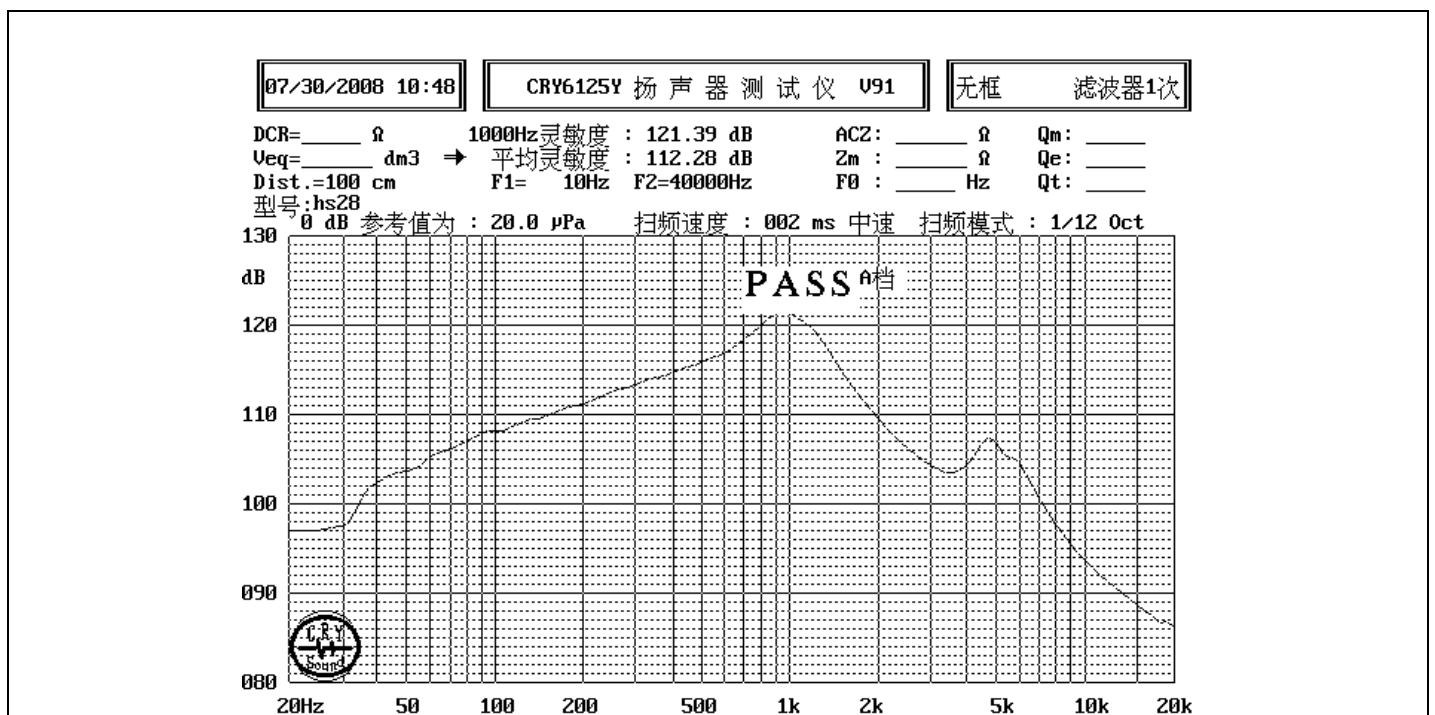

5.Design and Construction (喇叭尺寸图)

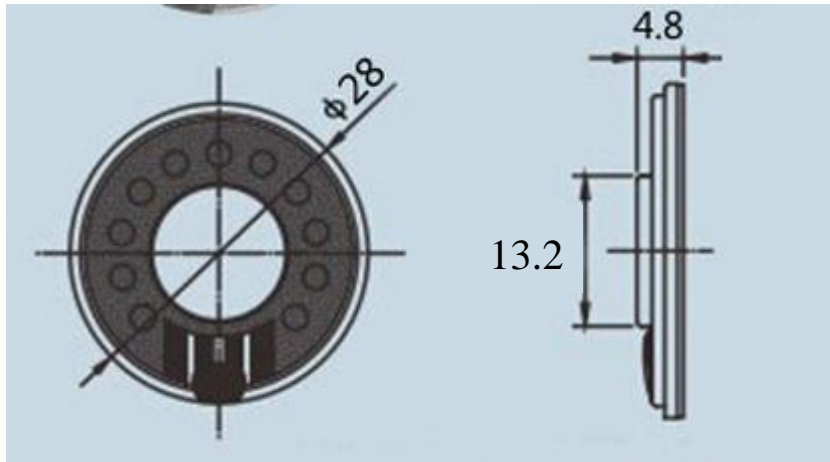

ART NAME	QUANTITY	MATERIAL (材质)	CHANGING ITEM (更改事项)
MAGNET (磁铁)	1		
CONE PAPER (振动膜)	1		
VOICE COIL (音圈)	1		
FRAME (支架)	1		
PCB (基板)	1		
Housing (壳体)			
装配 检验	试装 OK	外观 检验	OK