

MSKSEMI 美森科

SEMICONDUCTOR



ESD



TVS



TSS



MOV



GDT



PLED

MTXS0108E

Product specification

Description

This 8-Bit non-inverting translator which is a bidirectional voltage-level translator and can be used build digital switching compatibility between multi voltage systems. This IC uses two separate configurable power supply rails that including A ports supporting operating voltages from 1.65 V to 3.6 V with tracking V_{CCA} supply, and also including B ports supporting operating voltages from 2.3 V to 5.5V with tracking V_{CCB} supply.

The advantage above provides the support of both lower and higher logic signal levels while providing bidirectional translation capabilities between any of the 1.8-V, 2.5-V, 3.3-V, and 5- V voltage circuit points. Placing output-enable (OE) input to low level, all I/Os are forced to high-impedance state that significantly lower the quiescent current consumption. In order to ensure the high-impedance state during power up or power down, OE pin should be tied to GND via a pulldown resisto





Features

- No direction -control
- Data rates
24 Mbps (Push Pull)
2 Mbps (Open)
- 1.65 V to 3.6 V on A port and 2.3 V to 5.5 V on B port ($V_{CCA} \leq V_{CCB}$)
- VCC isolation feature: If either VCC input is at GND, both ports are in the high -impedance state
- No power -supply sequencing required: either V_{CCA} or V_{CCB} can be ramped first
- I_{off} supports partial -power -down mode operation
- Operating temperature range: -40°C to +85°C

Applications

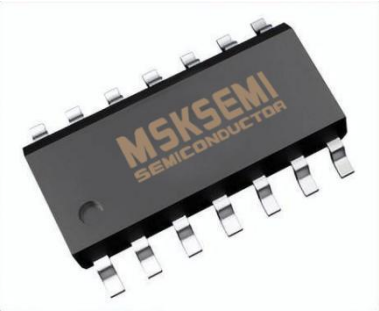
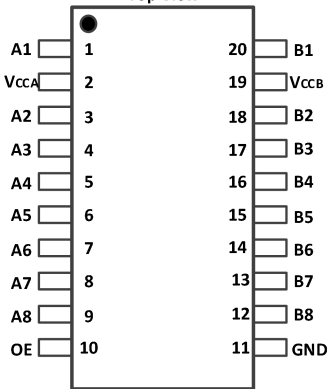
- Handset/Smartphone
- MART
- IPC
- GPIO

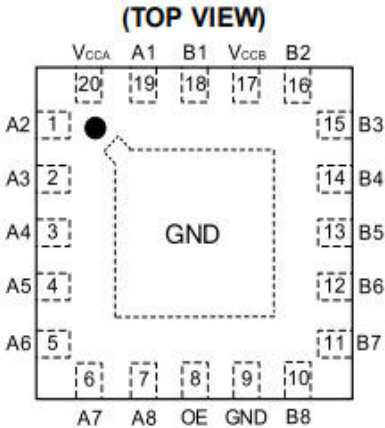
Reference News

TSSOP-20	Pinning and Package	Marking
	<p style="text-align: center;">Top View</p>  <p>Pinout diagram for TSSOP-20 package showing pins 1 through 20. Pins 1-10 are on the left side (A1, VCCA, A2, A3, A4, A5, A6, A7, A8, OE) and pins 11-20 are on the right side (B1, VCCB, B2, B3, B4, B5, B6, B7, B8, GND).</p>	 <p>MSKSEMI 0108EP WR MS**</p>
QFN3X3-20L	Pinning and Package	Marking
	<p style="text-align: center;">(TOP VIEW)</p>  <p>Pinout diagram for QFN3X3-20L package showing pins 1 through 20. Pins 1-5 are on the left side (A2, A3, A4, A5, A6) and pins 6-10 are on the bottom side (A7, A8, OE, GND, B8). Pins 11-16 are on the right side (B7, B6, B5, B4, B3) and pins 17-20 are on the top side (VCCB, B2, B1, VCCA).</p>	 <p>MSK 0108 MS***</p>

Device Summary, Pin and Packages (Continued)

NAME	PIN		I/O	Function
	EPWR	QGR		
A1	1	19	I/O	Input/Output 1. Referenced to V_{CCA} .
V_{CCA}	2	20	-	A-Port power supply.
A2	3	1	I/O	Input/Output 2. Referenced to V_{CCA} .
A3	4	2	I/O	Input/Output 3. Referenced to V_{CCA} .
A4	5	3	I/O	Input/Output 4. Referenced to V_{CCA} .
A5	6	4	I/O	Input/Output 5. Referenced to V_{CCA} .
A6	7	5	I/O	Input/Output 6. Referenced to V_{CCA} .
A7	8	6	I/O	Input/Output 7. Referenced to V_{CCA} .
A8	9	7	I/O	Input/Output 8. Referenced to V_{CCA} .
OE	10	8	I	Tri-state output mode. Pull low put all outputs in tri-state. Referenced to V_{CCA}
GND	11	9	-	Ground
B8	12	10	I/O	Input/Output 8. Referenced to V_{CCB}
B7	13	11	I/O	Input/Output 7. Referenced to V_{CCB}
B6	14	12	I/O	Input/Output 6. Referenced to V_{CCB}
B5	15	13	I/O	Input/Output 5. Referenced to V_{CCB}
B4	16	14	I/O	Input/Output 4. Referenced to V_{CCB}
B3	17	15	I/O	Input/Output 3. Referenced to V_{CCB}
B2	18	16	I/O	Input/Output 2. Referenced to V_{CCB}
V_{CCB}	19	17	-	B-Port power supply
B1	20	18	I/O	Input/Output 1. Referenced to V_{CCB}

Order information

Orderable Device	Package	Packing Option
MTXS0108EPWR	TSSOP-20	2000PCS
MTXS0108ERGYR	QFN3X3-20L	3000PCS

Circuit Diagram

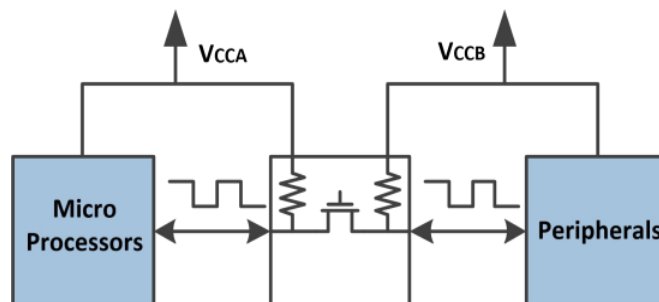

Absolute Maximum Ratings

Parameters		Min	Max	Unit
Supply voltage, V_{CCA}		-0.3	6.0	V
Supply voltage, V_{CCB}		-0.3	6.0	V
Input voltage range, V_i	A port	-0.3	6.0	V
	B port	-0.3	6.0	
Voltage range applied to any output in the high-impedance or power-off state, V_o	A port	-0.3	6.0	V
	B port	-0.3	6.0	
Voltage range applied to any output in the high or low state, V_o	A port	-0.3	$V_{CCA}+0.3$	V
	B port	-0.3	$V_{CCB}+0.3$	
Input clamp current, I_{IK}	$V_i < 0$		-50	mA
Output clamp current, I_{OK}	$V_o < 0$		-50	mA
Continuous output current, I_o			± 50	mA
Continuous current through V_{CCA}, V_{CCB} or GND			± 100	mA
Maximum junction temperature			150	$^{\circ}\text{C}$
Storage temperature range		-65	150	$^{\circ}\text{C}$

(1) Stresses above these ratings may cause permanent damage. Exposure to absolute maximum conditions for extended periods may degrade device reliability. These are stress ratings only, and functional operation of the device at these or any other conditions beyond those specified is not implied.

(2) The input and output negative-voltage ratings may be exceeded if the input and output current ratings are observed

(3) The value of V_{CCA} and V_{CCB} are provided in the recommended operating conditions table.

ESD Ratings

ESD			Value	Unit
V(ESD)	Electrostatic Discharge	Human-Body Model (HBM) ⁽¹⁾	$\pm 3\text{K}$	V
		Charged-Device Model (CDM) ⁽²⁾	$\pm 2\text{K}$	V

(1) JEDEC document JEP155 states that 500-V HBM allows safe manufacturing with a standard ESD control process.

(2) JEDEC document JEP157 states that 250-V CDM allows safe manufacturing with a standard ESD control process.

Recommended Operating Conditions

V_{CCI} is the supply voltage associated with the input port. V_{CCO} is the supply Voltage associated with the output port.

Parameter	Conditions		Min	Typ	Max	Unit
Supply voltage ⁽¹⁾	V_{CCA}		1.65		3.6	V
	V_{CCB}		2.3		5.5	
High-level input voltage (V_{IH})	A-port I/Os	$V_{CCA}=1.65\text{ V to }1.95\text{ V}$ $V_{CCB}=2.3\text{ V to }5.5\text{ V}$	$V_{CCI}-0.2$		V_{CCI}	V
		$V_{CCA}=2.3\text{ V to }3.6\text{ V}$ $V_{CCB}=2.3\text{ V to }5.5\text{ V}$	$V_{CCI}-0.4$		V_{CCI}	
	B-port I/Os	$V_{CCA}=1.65\text{ V to }3.6\text{ V}$ $V_{CCB}=2.3\text{ V to }5.5\text{ V}$	$V_{CCI}-0.4$		V_{CCI}	
	OE input	$V_{CCA}=1.65\text{ V to }3.6\text{ V}$ $V_{CCB}=2.3\text{ V to }5.5\text{ V}$	$V_{CCI} \times 0.8$		5.5	
Low-level input voltage (V_{IL}) ⁽²⁾	A-port I/Os	$V_{CCA}=1.65\text{ V to }1.95\text{ V}$ $V_{CCB}=2.3\text{ V to }5.5\text{ V}$	0		0.15	V
	B-port I/Os	$V_{CCA}=1.65\text{ V to }3.6\text{ V}$ $V_{CCB}=2.3\text{ V to }5.5\text{ V}$	0		0.15	
OE	OE input	$V_{CCA}=1.65\text{ V to }3.6\text{ V}$ $V_{CCB}=2.3\text{ V to }5.5\text{ V}$	0		$V_{CCA} \times 0.25$	V
Input transition rise or fall rate ($\Delta t/\Delta v$)	A-port I/Os push-pull driving				10	ns/V
	B-port I/Os push-pull driving				10	
	Control input				10	
TA Operating free- air temperature	-		-40		85	°C

(1) V_{CCA} must be less than or equal to V_{CCB} .

(2) The maximum V_{IL} value is provided to ensure that a valid V_{OL} is maintained. The V_{OL} value is V_{IL} plus the voltage drop across the pass gate transistor.

Electrical Characteristics

 over recommended operating free-air temperature range (unless otherwise noted) ⁽¹⁾ ⁽²⁾ ⁽³⁾

Parameter		Conditions	V _{CCA}	V _{CCB}	Temp	Min	Typ	Max	Unit
V _{OHA}	PortA Output High Voltage	$I_{OH} = -20 \mu A$ $V_{IB} \geq V_{CCB} - 0.4V$	1.65V to 3.6V	2.3V to 5.5V	Full	$V_{CCA} \times 0.7$			V
V _{OLA}	PortA Output Low Voltage	$I_{OL} = 1mA$ $V_{IB} \leq 0.15V$	1.65V to 3.6V	2.3V to 5.5V	Full			0.3	V
V _{OHB}	Port B Output High Voltage	$I_{OH} = -20 \mu A$ $V_{IA} \geq V_{CCA} - 0.4V$	1.65V to 3.6V	2.3V to 5.5V	Full	$V_{CCA} \times 0.7$			V
V _{OLB}	Port B Output Low Voltage	$I_{OL} = 1mA$ $V_{IA} \leq 0.15V$	1.65V to 3.6V	2.3V to 5.5V	Full			0.3	V
I _i	Input Leakage Current	OE	1.65V to 3.6V	2.3V to 5.5V	+25°C			±1	μA
					Full			±1.5	
I _{bff}	Partial Power Down Current	A Ports	0V	0V to 5.5V	+25°C			±0.5	μA
					Full			±1	
		B Ports	0V to 3.6V	0V	+25°C			±0.5	
					Full			±1	
I _{oz}	High-impedance State Output Current	A or B port OE=0V	1.65V to 3.6V	2.3V to 5.5V	+25°C			±0.5	μA
					Full			±1	
I _{CCA}	V _{CCA} Supply Current	V _i =V _o =open I _b =0	1.65V to V _{CCB}	2.3v to 5.5V	Full			2.5	μA
			3.6v	0V	Full			2.5	
			0v	5.5V	Full			-1	
I _{CCB}	V _{CCB} Supply Current	V _i =V _o =open I _b =0	1.65V to V _{CCB}	2.3v to 5.5V	Full			10	μA
			3.6v	0V	Full			-1	
			0v	5.5V	Full			1	
I _{CCA} + I _{CCB}	Combined Supply Current	V _i =V _{CCi} or GND I _b =0	1.65V to V _{CCB}	2.3v to 5.5V	Full			13	μA
I _{CCZA}	V _{CCA} Supply Current	V _i =V _{CCi} or 0V I _b =0, OE=0V	1.65V to V _{CCB}	2.3v to 5.5V	Full			1	μA
I _{CCZB}	V _{CCB} Supply Current	V _i =V _{CCi} or 0V I _b =0, OE=0V	2.3v to 3.6V	2.3v to 5.5V	Full			1	μA
C _i	Input Capacitance	OE	3.3V	3.3V	+25°C		2.5		PF
C _{io}	Input-to-output Internal Capacitance	A Port	3.3V	3.3V	+25°C		5		PF
		B Port	3.3V	3.3V	+25°C		5		

 (1) V_{CCi} is the VCC associated with the input port.

 (2) V_{CCo} is the VCC associated with the output port

 (3) V_{CCA} must be less than or equal to V_{CCB}.

Timing Requirements

 $V_{CCA}=1.8V\pm 0.15V$

		$V_{CCB}=2.5V\pm 0.2V$	$V_{CCB}=3.3V\pm 0.2V$	$V_{CCB}=5V\pm 0.2V$	Unit
		Typ	Typ	Typ	
Data Rate	Push-pull Driving	21	22	24	Mbps
	Open-drain Driving	2	2	2	
Pulse Duration(tw)	Push-pull Driving (Data Inputs)	47	45	41	ns
	Open-drain Driving (Data Inputs)	500	500	500	

 $V_{CCA}=2.5V\pm 0.15V$

		$V_{CCB}=2.5V\pm 0.2V$	$V_{CCB}=3.3V\pm 0.2V$	$V_{CCB}=5V\pm 0.2V$	Unit
		Typ	Typ	Typ	
Data Rate	Push-pull Driving	20	22	24	Mbps
	Open-drain Driving	2	2	2	
Pulse Duration(tw)	Push-pull Driving (Data Inputs)	50	45	41	ns
	Open-drain Driving (Data Inputs)	500	500	500	

 $V_{CCA}=3.3V\pm 0.15V$

		$V_{CCB}=3.3V\pm 0.2V$	$V_{CCB}=5V\pm 0.2V$	Unit
		Typ	Typ	
Data Rate	Push-pull Driving	23	24	Mbps
	Open-drain Driving	2	2	
Pulse Duration(tw)	Push-pull Driving (Data Inputs)	43	41	ns
	Open-drain Driving (Data Inputs)	500	500	

Switching Characteristics:Vcc=1.8V±0.15V

over recommended operating free-air temperature range (unless otherwise noted)

Parameter		Conditions		V _{ccB} =2.5V±0.2V	V _{ccB} =3.3V±0.2V	V _{ccB} =5V±0.2V	Units
				Typ	Typ	Typ	
t _{PHL}	Propagation Delay Time High-to-low Output	A to B	Push-pull Driving	5.6	5	5	ns
			Open-drain Driving	7.5	7.9	8.3	
t _{PLH}	Propagation Delay Time low-to-high Output	A to B	Push-pull Driving	10.0	9.5	9	ns
			Open-drain Driving	181	170	154	
t _{PHL}	Propagation Delay Time High-to-low Output	B to A	Push-pull Driving	7	7.1	7.2	ns
			Open-drain Driving	7.6	8.1	9.2	
t _{PLH}	Propagation Delay Time low-to-high Output	B to A	Push-pull Driving	7.6	6.9	6	ns
			Open-drain Driving	163	145	118	
t _{en}	Enable Time	OE to A or B		135	159	182	ns
t _{dis}	Disable Time	OE to A or B		170	174	181	ns
t _{rA}	Input Rise Time	A port rise time	Push-pull Driving	134	11.9	10.6	ns
			Open-drain Driving	68	66	62	
t _{rB}	Input Rise Time	B port rise time	Push-pull Driving	13	12	11.6	ns
			Open-drain Driving	66	65	50	
t _{fA}	Input Fall Time	Aport fall time	Push-pull Driving	5.6	4.7	4.0	ns
			Open-drain Driving	5.0	5.1	5.2	
t _{fB}	Input Fall Time	Bport fall time	Push-pull Driving	3.0	3.0	2.9	ns
			Open-drain Driving	6.1	5.6	4.4	
t _{SK(O)}	Skew(time), Output	Channel-to-Channel Skew		0.5	0.5	0.5	ns
Maximum Data Rate		Push-pull Driving		22	23	24	Mbps
		Open-drain Driving		2	2	2	

Switching Characteristics: $V_{CC}=2.5V\pm 0.15V$

over operating free-air temperature range (unless otherwise noted)

Parameter		Conditions		$V_{CCB}=2.5V\pm 0.2V$	$V_{CCB}=3.3V\pm 0.2V$	$V_{CCB}=5V\pm 0.2V$	Units
				Typ	Typ	Typ	
t_{PHL}	Propagation Delay Time High-to-low Output	A to B	Push-pull Driving	3.5	3.5	3.2	ns
			Open-drain Driving	6.3	6.5	6.7	
t_{PLH}	Propagation Delay Time low-to-high Output	A to B	Push-pull Driving	4.5	4.9	4.7	ns
			Open-drain Driving	158	152	142	
t_{PHL}	Propagation Delay Time High-to-low Output	B to A	Push-pull Driving	3.7	3.9	4.6	ns
			Open-drain Driving	6	6.6	7.7	
t_{PLH}	Propagation Delay Time low-to-high Output	B to A	Push-pull Driving	4.8	4	2.5	ns
			Open-drain Driving	153	138	116	
t_{en}	Enable Time	OE to A or B		7.7	41.8	130	ns
t_{dis}	Disable Time	OE to A or B		175	181	182	ns
t_{rA}	Input Rise Time	A port Rise Time	Push-pull Driving	9.8	8.6	7.5	ns
			Open-drain Driving	79	77	65	
t_{rB}	Input Rise Time	B port Rise Time	Push-pull Driving	9.8	8.7	8.1	ns
			Open-drain Driving	93	68	53	
t_{fA}	Input Fall Time	A port Fall Time	Push-pull Driving	4.6	4.1	3.6	ns
			Open-drain Driving	5.1	5.1	5.2	
t_{fB}	Input Fall Time	B port Fall Time	Push-pull Driving	4.5	4.0	4.0	ns
			Open-drain Driving	6.9	7.4	7.8	
$t_{sk(O)}$	Skew(time), Output	Channel-to-Channel Skew		0.5	0.5	0.5	ns
Maximum Data Rate		Push-pull Driving		22	24	24	Mbps
		Open-drain Driving		2	2	2	

Switching Characteristics:Vcc=3.3V±0.3V

over recommended operating free-air temperature range (unless otherwise noted)

Parameter		Conditions		V _{ccB} =3.3V±0.2V	V _{ccB} =5V±0.2V	Units
				TYP	TYP	
t _{PHL}	Propagation Delay Time High-to-low Output	A to B	Push-pull Driving	2.1	2.2	ns
			Open-drain Driving	5.9	6.1	
t _{PLH}	Propagation Delay Time High-to-low Output	A to B	Push-pull Driving	1	3.3	ns
			Open-drain Driving	138	131	
t _{PHL}	Propagation Delay Time High-to-low Output	B to A	Push-pull Driving	2.3	2.6	ns
			Open-drain Driving	5.4	6.6	
t _{PLH}	Propagation delay time low-to-high Output	B to A	Push-pull Driving	1.0	1.0	ns
			Open-drain Driving	133	115	
t _{en}	Enable Time	OE to A or B		4.7	5.2	ns
t _{dis}	Disable Time	OE to A or B		174	182	ns
t _{rA}	Input Rise Time	A port Rise Time	Push-pull Driving	7.4	6.6	ns
			Open-drain Driving	75	67	
t _{rB}	Input Rise Time	B port Rise Time	Push-pull Driving	7.7	7.1	ns
			Open-drain Driving	70	65	
t _{fA}	Input Fall Time	Aport Fall Time	Push-pull Driving	3.4	3.0	ns
			Open-drain Driving	5.1	5.1	
t _{fB}	Input Fall Time	Bport Fall Time	Push-pull Driving	3.5	3.2	ns
			Open-drain Driving	6.8	6.7	
t _{sk(O)}	Skew(time), Output	Channel-to-Channel Skew		0.5	0.5	ns
Maximum Data Rate		Push-pull Driving		24	24	Mbps
		Open-drain Driving		2	2	

Typical Characteristics

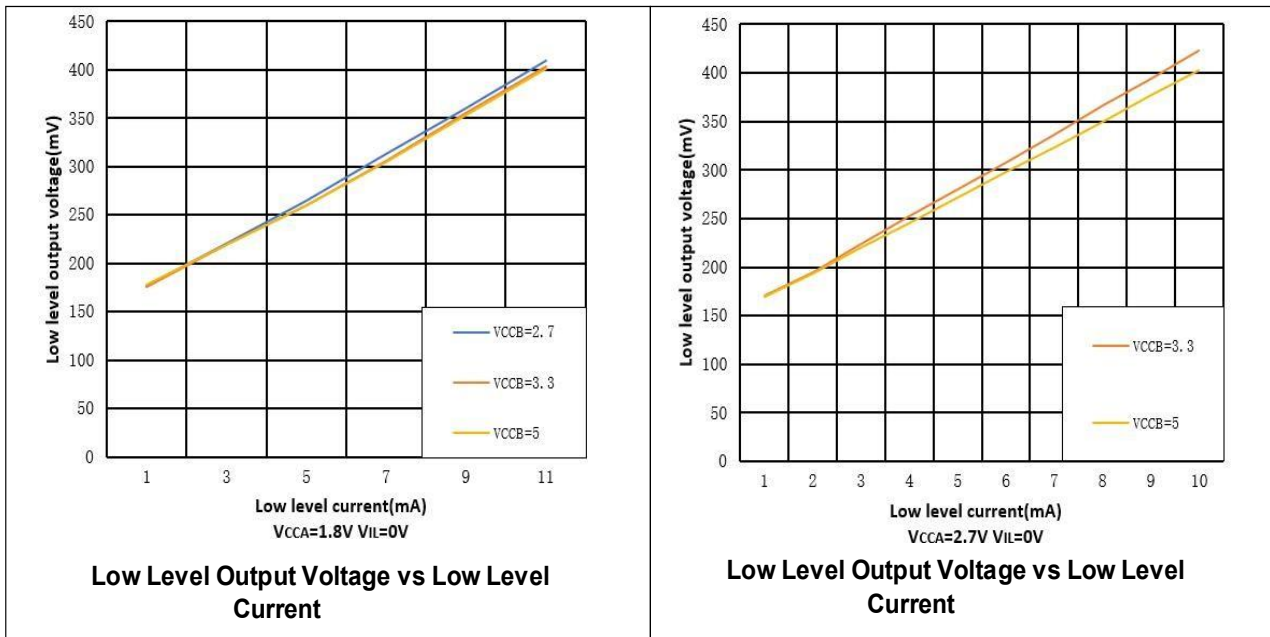

Parameter Measurement Information

Unless otherwise noted, all input pulsed are supplied by generators having the following characteristics:

- PSRR 10MHz
- $Z_o=50 \Omega$
- $dv/dt \geq 1V/ns$

Note: All input pulses are measured one at a time with one transition per measurement

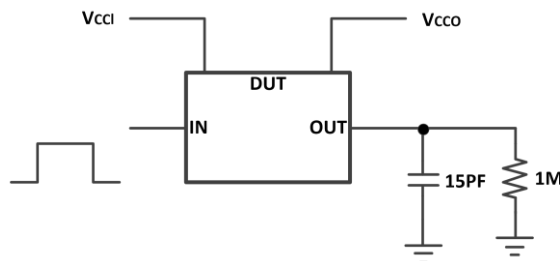

Data Rate, Pulse Duration, Propagation Delay, Output Rise and Fall Time Measurement Using a Push-Pull Driver

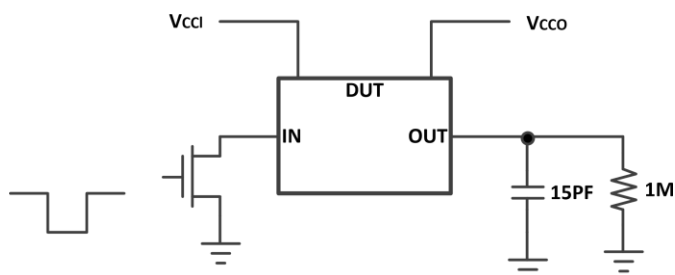

Data Rate, Pulse Duration, Propagation Delay, Output Rise and Fall Time Measurement Using an Open-Drain Driver

Parameter Measurement Information (Continued)

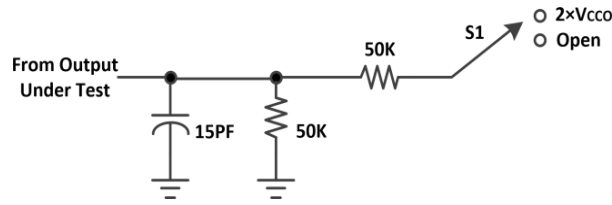

Load Circuit for Enable/Disable Time Measurement

Switch Configuration for Enable/Disable Timing

Test	S1
$t_{PZL}^{(1)}$, $t_{PLZ}^{(2)}$	$2 \times V_{CC0}$
$t_{PHZL}^{(1)}$, $t_{PZH}^{(2)}$	Open

(1) t_{PZL} and t_{PZH} are the same as t_{en} .

(2) t_{PLZ} and t_{PHZ} are the same as t_{dis} .

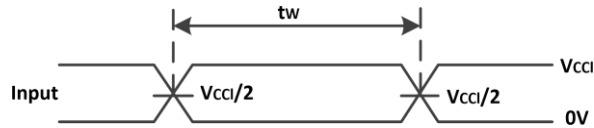

(1) All input pulses are measured one at a time, with one transition per measurement.

Voltage Waveforms Pulse Duration

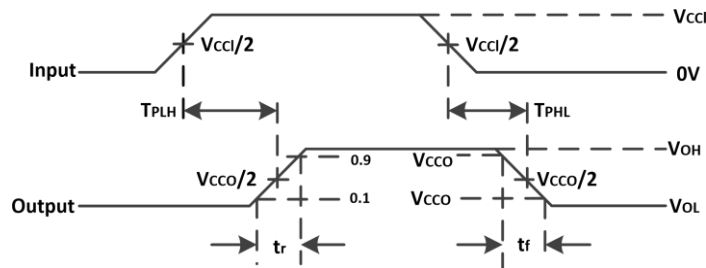

Voltage Waveforms Propagation Delay Times

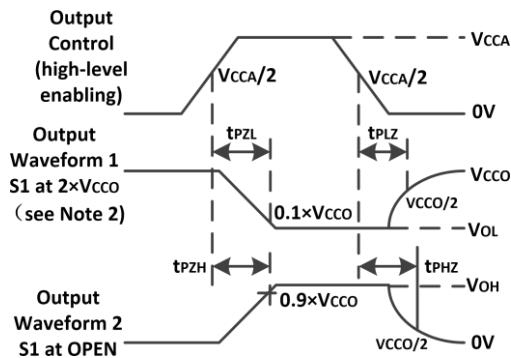

Voltage Waveforms Enable and Disable

Overview

The MTXS0108E IC is a Bi-direction voltage-level translator specifically designed for translating logic voltage levels. The A port can accept I/O voltages that cover from 1.65 V to 3.6 V range; The B port can accept I/O voltages from 2.3 V to 5.5 V. The device is a pass-gate architecture with edge-rate accelerators (one-shots) to improve the overall data rate. 10-kΩ pullup resistors that usually used in open-drain applications have been integrated inside IC with the advantage saving an external resistor. Not only the IC is designed for open-drain applications, but also this device can translate push-pull CMOS logic outputs.

Architecture

The MTXS0108E architecture (see Figure below) is a translator with Bi-direction-Sensing function that means a direction-control mechanism to control the direction of data flow from A to B or from B to A is not needed. These two bidirectional channels independently determine the direction of data flow without a direction-control signal. This auto-direction feature is realized by each I/O pin can be automatically reconfigured as either an input or an output.

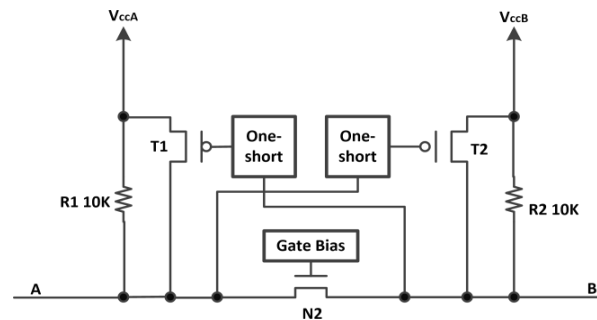

Architecture of MTXS0108E

Application Information

The MTXS0108E device can be used to bridge the digital-switching compatibility gap between two voltage nodes to successfully interface logic threshold levels found in electronic systems. It should be used in a point-to-point topology for interfacing devices or systems operating at different interface voltages with one another. Its primary target application use is for interfacing with open-drain drivers on the data I/Os such as I2C or 1-wire, where the data is bidirectional and no control signal is available. The device can also be used in applications where a push-pull driver is connected to the data I/Os, but the MTXS0108E might be a better option for such push-pull applications.

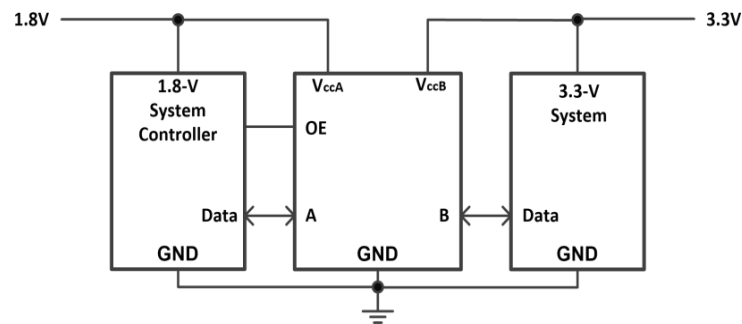

Typical Application Schematic

Package Outline Dimension

TSSOP-20

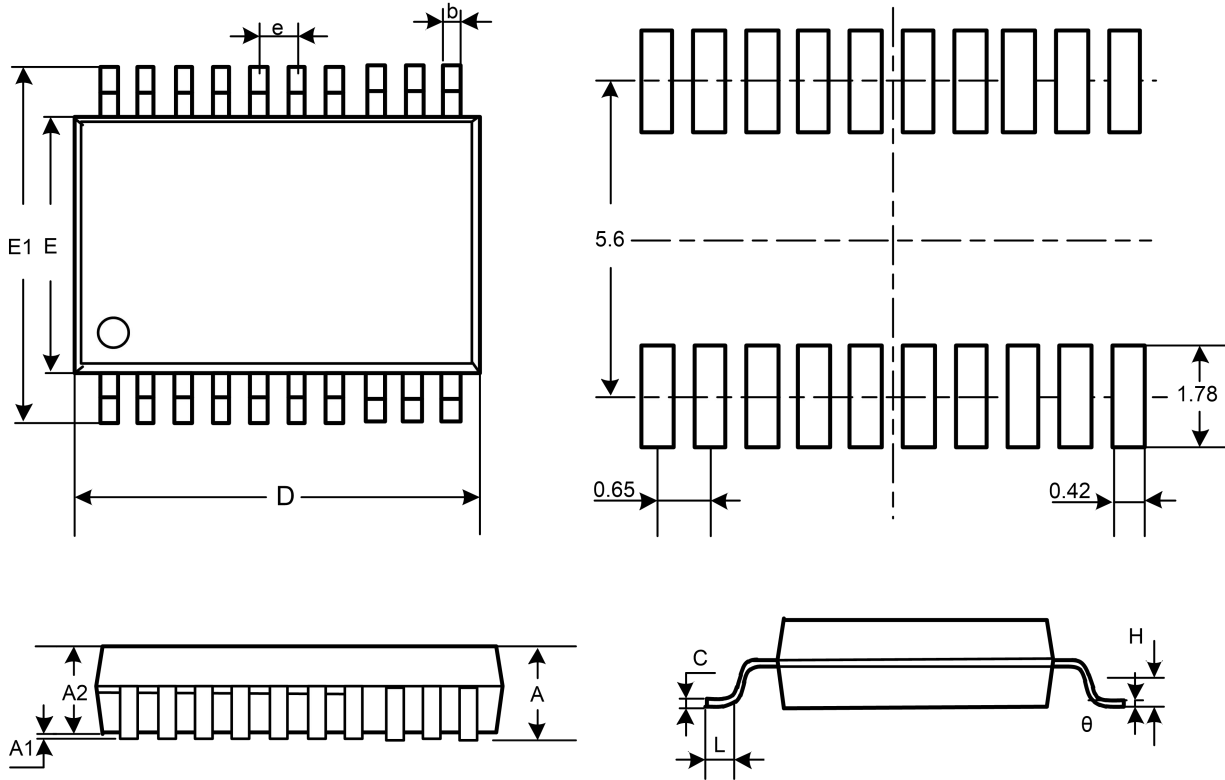

Symbol	Dimensions In Millimeters		Dimensions In Inches	
	Min	Max	Min	Max
A		1.200		0.047
A1	0.050	0.150	0.002	0.006
A2	0.800	1.050	0.031	0.041
b	0.200	0.280	0.008	0.011
c	0.130	0.170	0.005	0.007
D	6.400	6.600	0.252	0.260
E	4.300	4.500	0.169	0.177
E1	6.200	6.600	0.244	0.260
e	0.65BSC		0.026BSC	
L	0.450	0.750	0.018	0.030
H	0.25TYP		0.01TYP	
θ	0°	8°	0°	8°

Package Outline Dimension

QFN3×3-20L

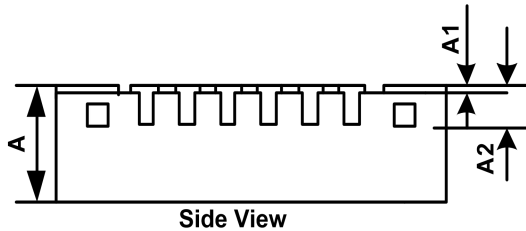
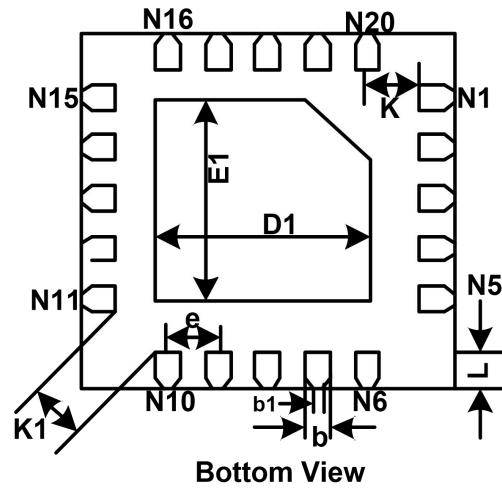
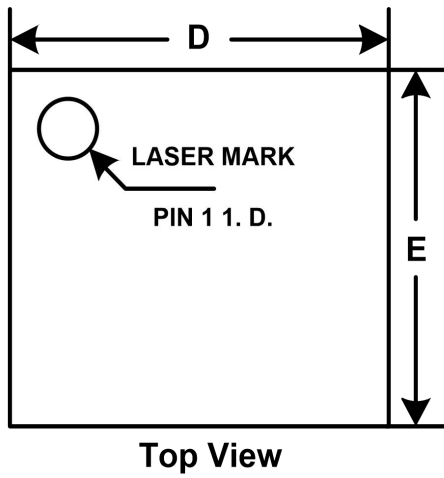

Symbol	Dimensions In Millimeters		Dimensions In Inches	
	Min	Max	Min	Max
A	0.700	0.800	0.	0.
A1	0.000	0.050	0280.	0310.
A2	0.203REF		0.008REF	
D	2.950	3.050	0000.	0020.
E	2.950	3.050	1160.	1200.
D1	1.550	1.650	1160.	1200.
E1	1.550	1.650	0610.	0650.
K	0.300REF		061	0.012REF 065
K1	0.400REF		0.016REF	
b	0.150	0.250	0.006	0.010
b1	0.150REF		0.006REF	
e	0.400BSC		0.016BSC	
L	0.350	0.450	0.014	0.018

Attention

- Any and all MSKSEMI Semiconductor products described or contained herein do not have specifications that can handle applications that require extremely high levels of reliability, such as life-support systems, aircraft's control systems, or other applications whose failure can be reasonably expected to result in serious physical and/or material damage. Consult with your MSKSEMI Semiconductor representative nearest you before using any MSKSEMI Semiconductor products described or contained herein in such applications.
- MSKSEMI Semiconductor assumes no responsibility for equipment failures that result from using products at values that exceed, even momentarily, rated values (such as maximum ratings, operating condition ranges, or other parameters) listed in products specifications of any and all MSKSEMI Semiconductor products described or contained herein.
- Specifications of any and all MSKSEMI Semiconductor products described or contained herein stipulate the performance, characteristics, and functions of the described products in the independent state, and are not guarantees of the performance, characteristics, and functions of the described products as mounted in the customer's products or equipment. To verify symptoms and states that cannot be evaluated in an independent device, the customer should always evaluate and test devices mounted in the customer's products or equipment.
- MSKSEMI Semiconductor strives to supply high-quality high-reliability products. However, any and all semiconductor products fail with some probability. It is possible that these probabilistic failures could give rise to accidents or events that could endanger human lives, that could give rise to smoke or fire, or that could cause damage to other property. When designing equipment, adopt safety measures so that these kinds of accidents or events cannot occur. Such measures include but are not limited to protective circuits and error prevention circuits for safe design, redundant design, and structural design.
- In the event that any or all MSKSEMI Semiconductor products (including technical data, services) described or contained herein are controlled under any of applicable local export control laws and regulations, such products must not be exported without obtaining the export license from the authorities concerned in accordance with the above law.
- No part of this publication may be reproduced or transmitted in any form or by any means, electronic or mechanical, including photocopying and recording, or any information storage or retrieval system, or otherwise, without the prior written permission of MSKSEMI Semiconductor.
- Information (including circuit diagrams and circuit parameters) herein is for example only ; it is not guaranteed for volume production. MSKSEMI Semiconductor believes information herein is accurate and reliable, but no guarantees are made or implied regarding its use or any infringements of intellectual property rights or other rights of third parties.
- Any and all information described or contained herein are subject to change without notice due to product/technology improvement, etc. When designing equipment, refer to the "Delivery Specification" for the MSKSEMI Semiconductor product that you intend to use.