

RoHS

REV.	ECN NO.	DESCRIPTION	DESIGN	APPROVAL	DATE
A1	NEW	新版发行	Chen HongJiang	Chen ZhiQiang	2025.05.08

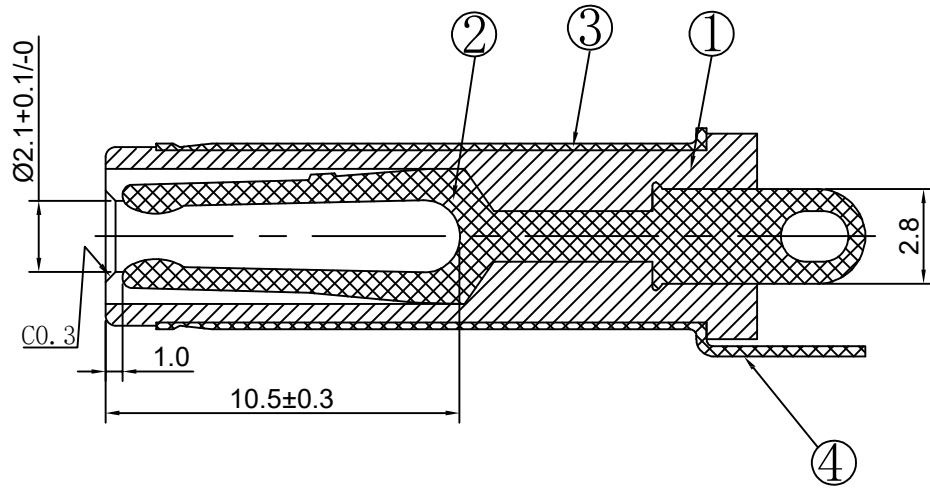
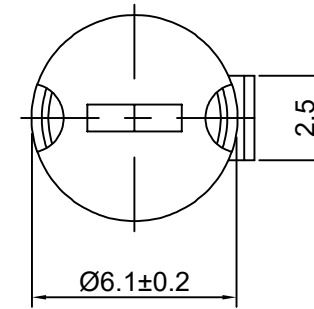
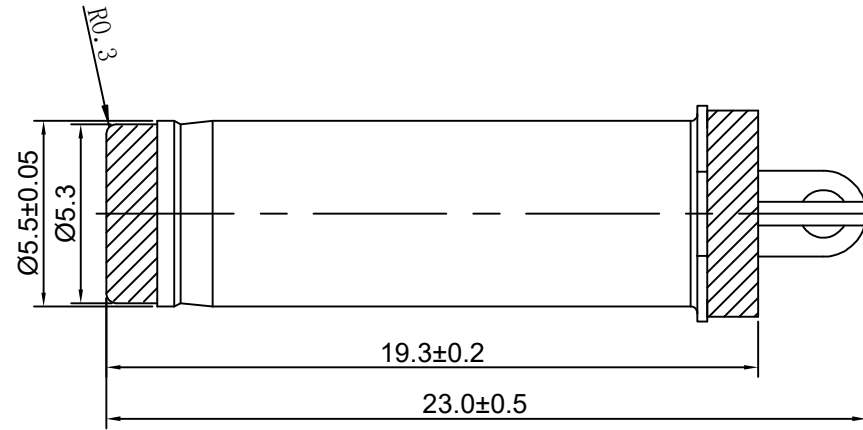
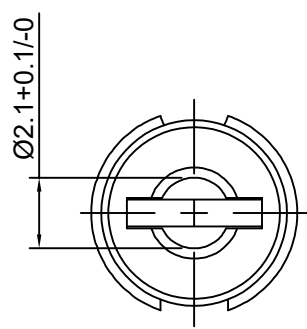

Technology Request:  
 1.Outlook;No burr,no hurt.  
 2.Electronic performance;  
 a.Insulation resistance;Above DC500V/100MΩ;  
 b.Endur voiage;AC500V at 1 minute  
 c.Contact resistance;Under 30mΩ  
 3.Insertion force & withdrawal force;0.3-3kgf  
 4.Salt spray test;24H  
 5.Meet RoHS.  
 6.Remark \* is important specification

NO	PART	MATERIAL	PLATING
4	焊片	H65	镀锡
3	外管	H65	Ni 40-120um
2	音叉片	C5191	Ni 40-120um
1	PBT	Black	

X±0.50	X.°±
.X±0.25	.X±
.XX±0.15	.XX°±
.XXX±0.10	.XXX°±
UNITS:	mm

THESE DRAWINGS AND SPECIFICATIONS ARE THE PROPERTY OF XFCN AND SHALL NOT BE REPRODUCED, COPIED OR CUED IN ANY MANNER WITHOUT THE PRIOR WRITTEN CONSENT OF XFCN

PART NO: XF-5521TVL225	
TITLE: DC PLUG 5.5* 2.1*22.5mm 音叉卡槽 平口 带焊片	
APPD	Chen ZhiQiang
CHKD	Liu Wei
DRAW	Chen HongJiang
DATE	2025.05.08

<b>XFCN</b> 兴飞连接器	
0769-82001899	
www.xfconn.com	
DWG NO:	
VIEW	
SCALE	SHEET
NONE	1/1
REV	A1