

## Product Overview

ICONICRF's ICP1240P is a 3 stage MMIC power amplifier in package form, fabricated using GaN on SiC technology. ICP1240P operates from 6-18GHz with 40dBm output power, over 20% PAE and 23dB typical small signal gain. ICP1240P is well suited to a variety of commercial, aerospace and defense applications.

### Key Features

- **Frequency Range: 6-18GHz**
- **P<sub>out</sub>: 40dBm @P<sub>in</sub>=24dBm**
- **PAE: 20% @P<sub>in</sub>=24dBm**
- **Small Signal Gain: 23dB**
- **Bias: V<sub>D</sub>=24V, I<sub>DQ</sub>=280mA**
- **Technology: GaN on SiC**
- **Lead-free and RoHS compliant**
- **CW operation**
- **Package Dimensions: 10mm x 20mm**

### Applications

- Test and Measurement
- Aerospace & Defense

### Electrical Specifications

Parameter	Min.	Typ.	Max.	Units	Conditions <sup>(1)</sup>
Frequency	6		18	GHz	
Output Power		40		dBm	P <sub>in</sub> = 24dBm
Power Added Efficiency, PAE		22		%	P <sub>in</sub> = 24dBm
Small Signal Gain, S <sub>21</sub>		23		dB	
Input Return Loss		15		dB	
Output Return Loss		7		dB	

**Note:** (1) Test conditions unless otherwise stated V<sub>D</sub>=24V, I<sub>DQ</sub>=280mA, T<sub>A</sub>=25°C, CW

### Functional Block Diagram

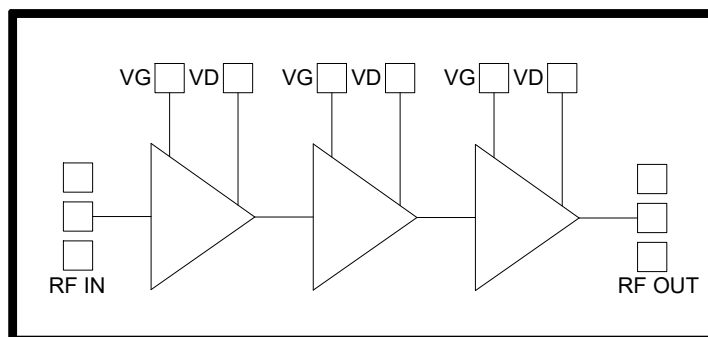

## Table of Contents

Product Overview.....	1
1. Electrical Specification.....	3
1.1. Absolute Maximum Ratings.....	3
1.2. Small Signal Performance.....	4
1.3. Large Signal Performance.....	5
2. Mechanical Drawing.....	11
3. Application Circuit.....	12
4. Evaluation Board.....	13
5. Other considerations.....	14
6. Ordering, Shipping, and Handling.....	15
Microchip Information.....	16
The Microchip Website.....	16
Product Change Notification Service.....	16
Customer Support.....	16
Microchip Devices Code Protection Feature.....	16
Legal Notice.....	16
Trademarks.....	17
Quality Management System.....	18
Worldwide Sales and Service.....	19

# 1. Electrical Specification

## 1.1 Absolute Maximum Ratings

Parameter	Absolute Maximum
Drain Voltage ( $V_D$ )	30V
CW Drain Current ( $I_D$ ), $T_A=25^\circ\text{C}$	5.9A
Gate Voltage Range ( $V_G$ )	-5 to 0V
Gate Current ( $I_G$ )	14mA
Power Dissipation (CW) $T_A=25^\circ\text{C}$	140W
Power Dissipation (CW) $T_A=85^\circ\text{C}$	108W
CW Input Power 50Ohm, $T_A=25^\circ\text{C}$	+28dBm
Input Power VSWR (2:1) $V_D=20\text{V}$ , $I_{DQ}=280\text{mA}$ $V_D=24\text{V}$ , $I_{DQ}=280\text{mA}$	+27dBm
Channel Temperature	275°C
Storage Temperature	-65°C to +150°C

### Thermal and Reliability

Parameter	Value
Thermal Resistance	1.75°C/W

- Assumes silver sintered epoxy attach (15µm thick) mounted on CuMo carrier.
- Base temperature is assumed at the top of the CuMo carrier
- Thermal resistance calculated using IR measurement of the channel temperature.

**Note:**

Exceeding any one or combination of these limits may cause permanent damage to this device.

Microchip Technology Inc. does not recommend sustained operation near these survivability limits.

## 1.2 Small Signal Performance

### Typical Power Dataover Temperature

Test conditions:  $V_D=24V$ ,  $I_{DQ}=280mA$

Figure 1-1.  $S_{21}$  vs Freq

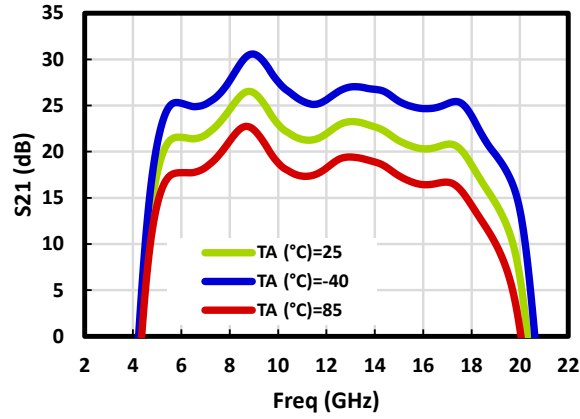

Figure 1-2.  $S_{11}$  vs Freq

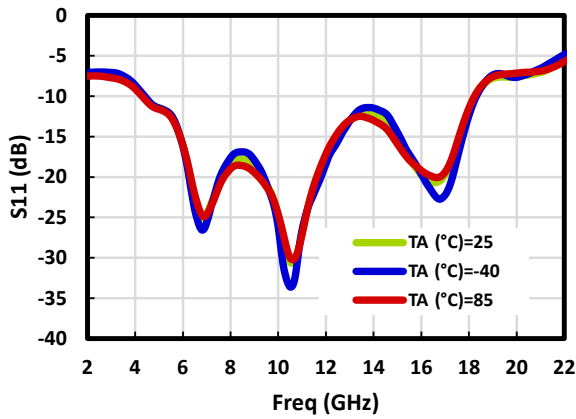
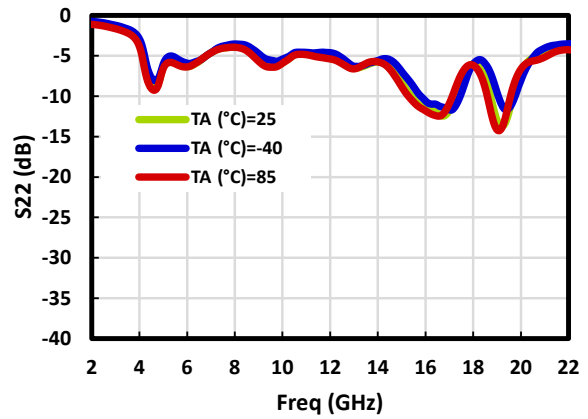

Figure 1-3.  $S_{22}$  vs Freq



### 1.3 Large Signal Performance

#### Typical CW Power Data

Test conditions:  $V_D=24V$ ,  $I_{DQ}=280mA$ ,  $T_A=25^\circ C$ , CW

Figure 1-4.  $P_{out}$  vs.  $P_{in}$

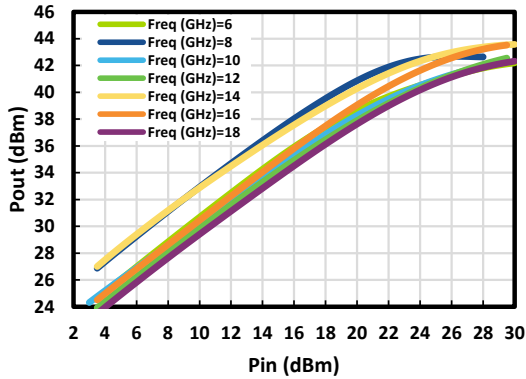

Figure 1-5. Gain vs.  $P_{out}$

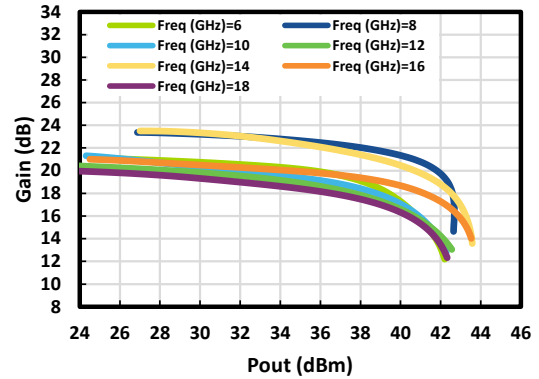

Figure 1-6. PAE vs.  $P_{out}$

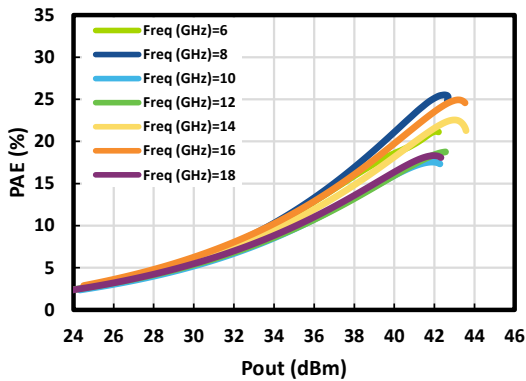

Figure 1-7.  $I_D$  vs.  $P_{out}$

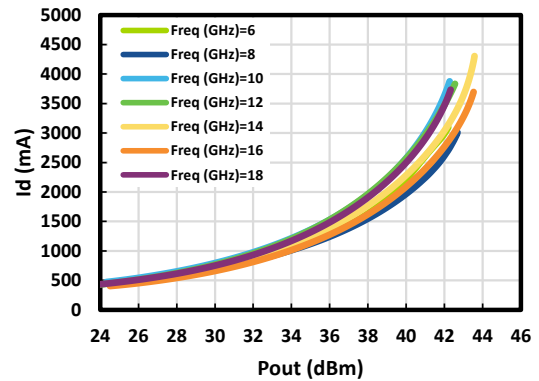

Figure 1-8.  $P_{out}$  vs. Freq.

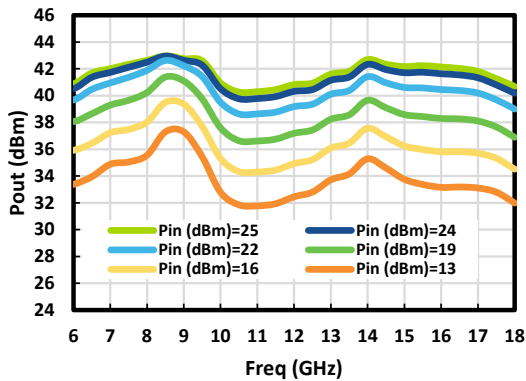
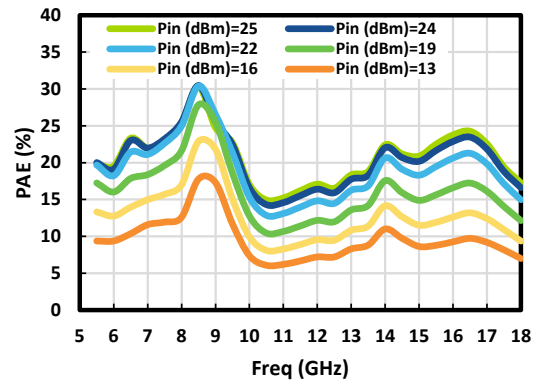

Figure 1-9. PAE vs. Freq.



### Typical CW Power Data over $V_D$

Test conditions:  $I_{DQ}=280\text{mA}$ ,  $T_A=25^\circ\text{C}$ , CW

Figure 1-10. Gain vs.  $P_{in}$  at 6GHz

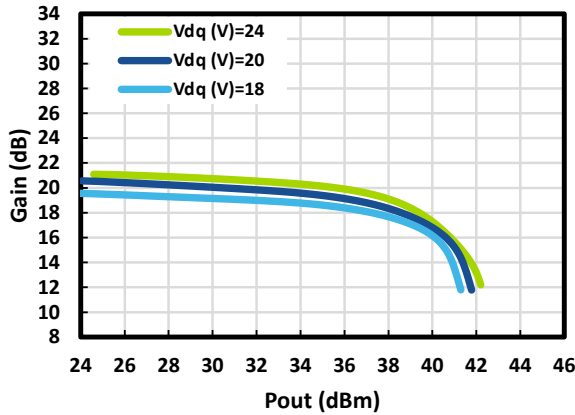

Figure 1-11. Gain vs.  $P_{out}$  at 10GHz

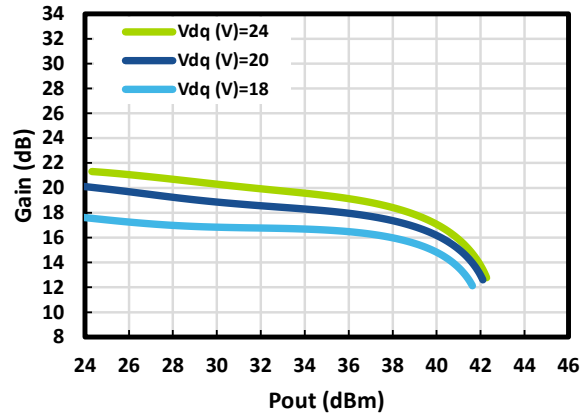

Figure 1-12. Gain vs.  $P_{in}$  at 14GHz

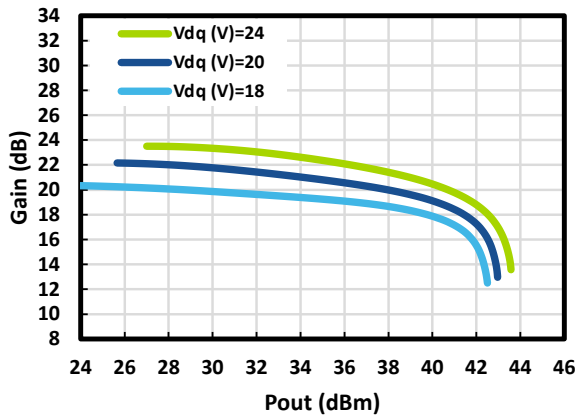

Figure 1-13. Gain vs.  $P_{out}$  at 18GHz

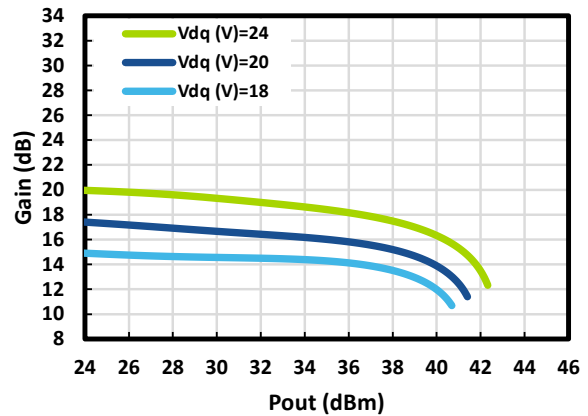

Figure 1-14.  $P_{out}$  vs. Freq.

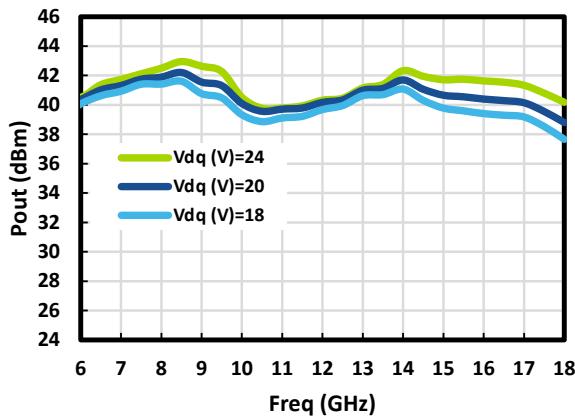
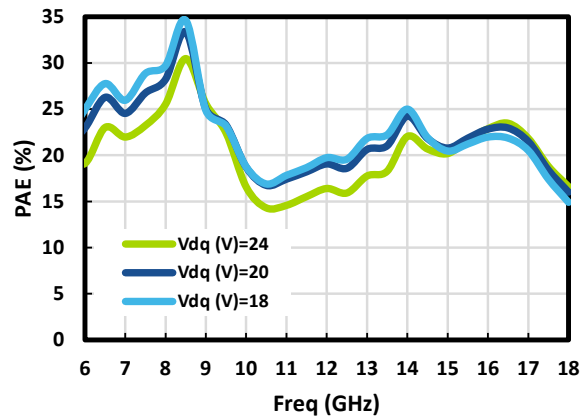

Figure 1-15. PAE vs. Freq.



### Typical CW Power Data over $T_A$

Test conditions:  $V_D=24V$ ,  $I_{DQ}=280mA$ , CW

Figure 1-16.  $P_{out}$  vs.  $P_{in}$  at 6GHz

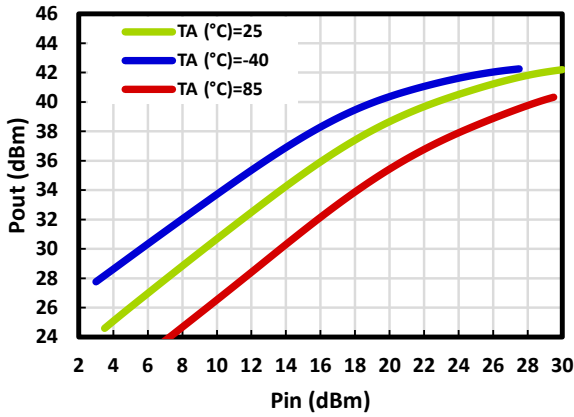

Figure 1-17. Gain vs.  $P_{out}$  at 6GHz

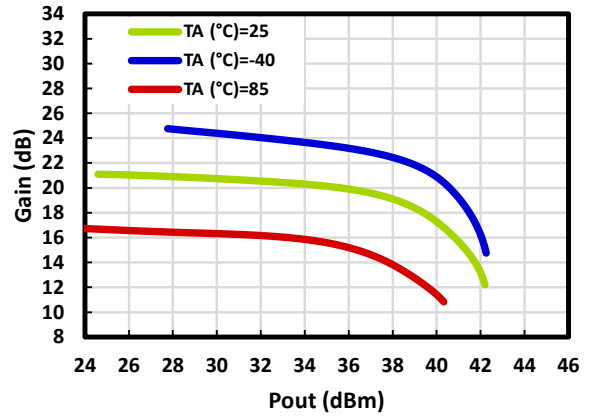

Figure 1-18.  $P_{out}$  vs.  $P_{in}$  at 12GHz

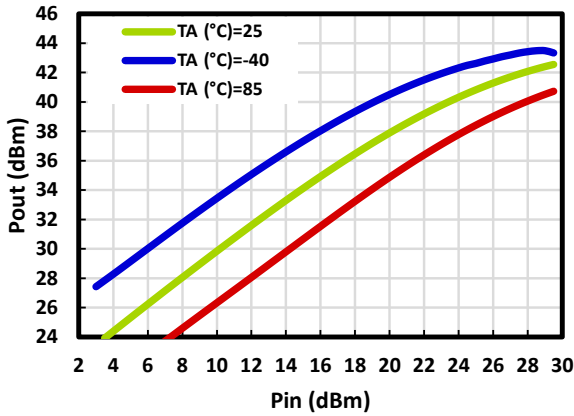

Figure 1-19. Gain vs.  $P_{out}$  at 12GHz

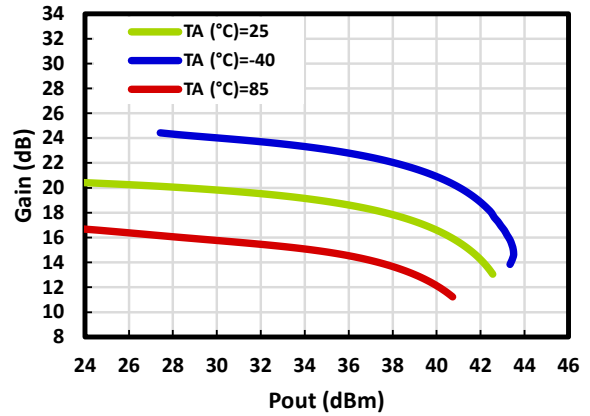

Figure 1-20.  $P_{out}$  vs.  $P_{in}$  at 18GHz

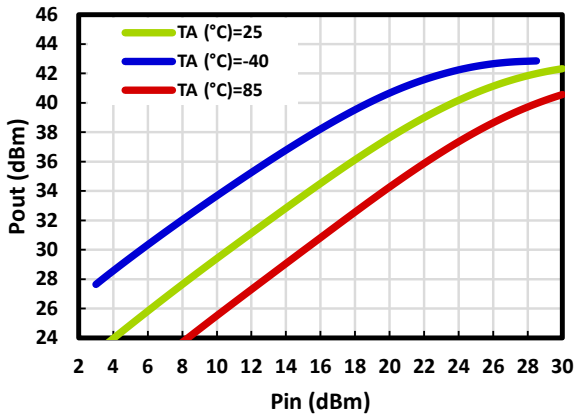
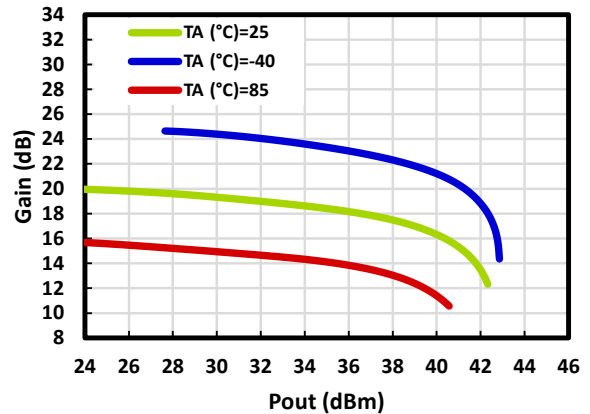

Figure 1-21. Gain vs.  $P_{out}$  at 18GHz



**Typical CW Power Data over  $T_A$  (Continued)**

Test conditions:  $V_D=24V$ ,  $I_{DQ}=280mA$ , CW

**Figure 1-22.** PAE vs.  $P_{out}$  at 6GHz

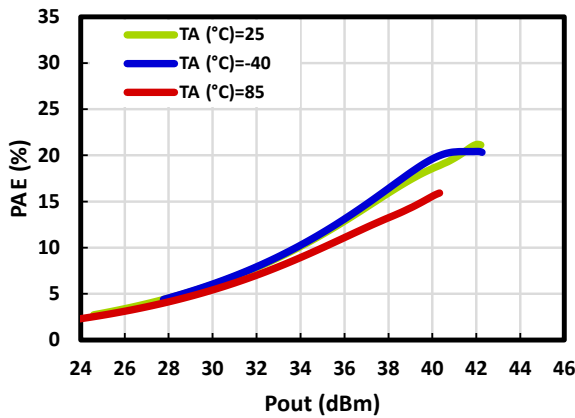

**Figure 1-23.**  $I_d$  vs.  $P_{out}$  at 6GHz

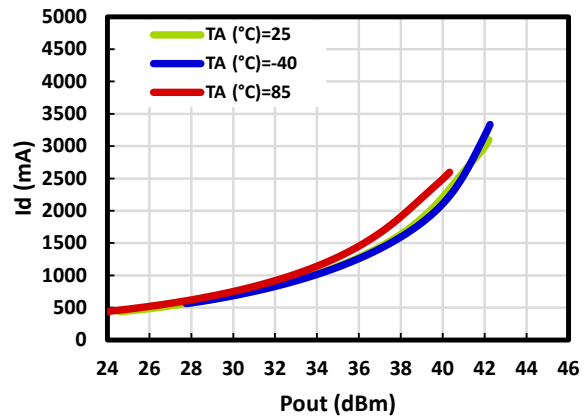

**Figure 1-24.** PAE vs.  $P_{out}$  at 12GHz

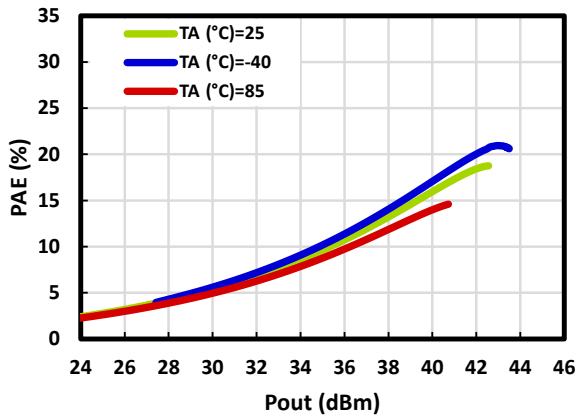

**Figure 1-25.**  $I_d$  vs.  $P_{out}$  at 12GHz

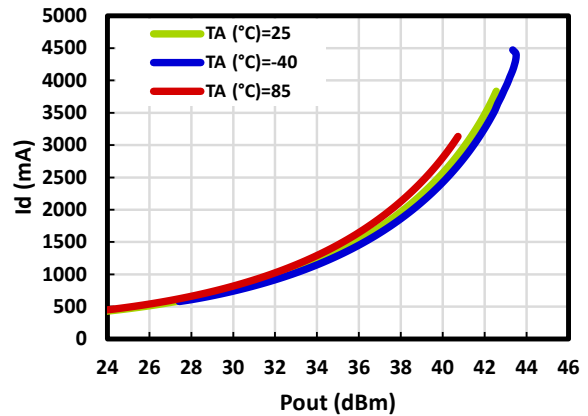

**Figure 1-26.** PAE vs.  $P_{out}$  at 18GHz

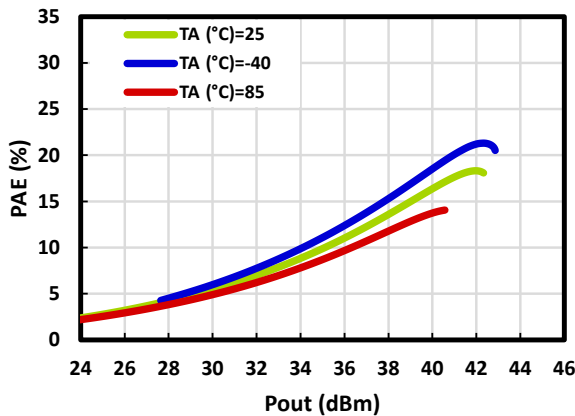

**Figure 1-27.**  $I_d$  vs.  $P_{out}$  at 18GHz

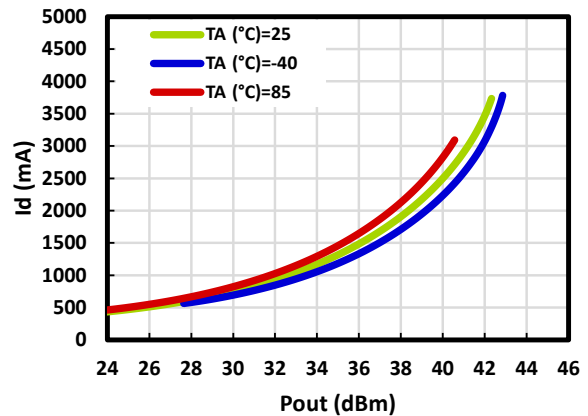

**Typical CW Power Data over T<sub>A</sub> (Continued)**

Test conditions: V<sub>D</sub>=24V, I<sub>DQ</sub>=280mA, P<sub>in</sub>=24dBm, CW

**Figure 1-28.** P<sub>out</sub> vs. Freq.

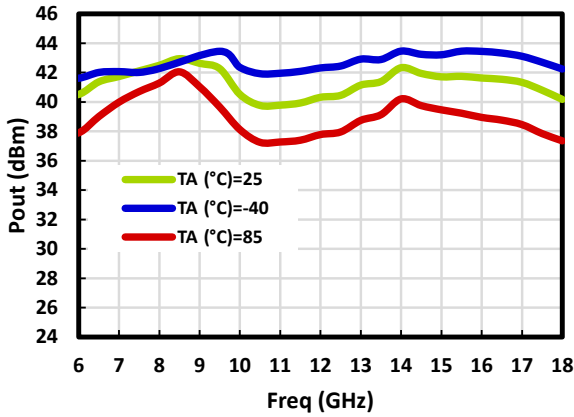

**Figure 1-29.** Gain vs. Freq.

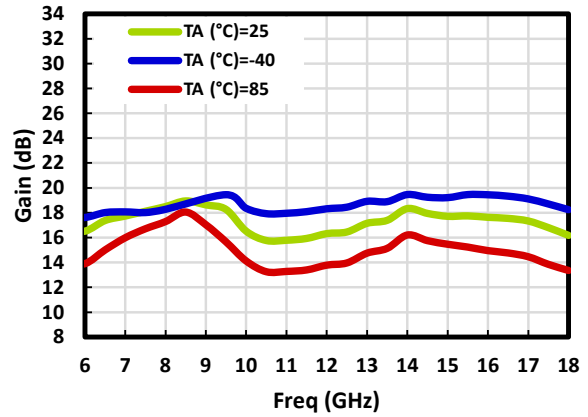

**Figure 1-30.** PAE vs. Freq.

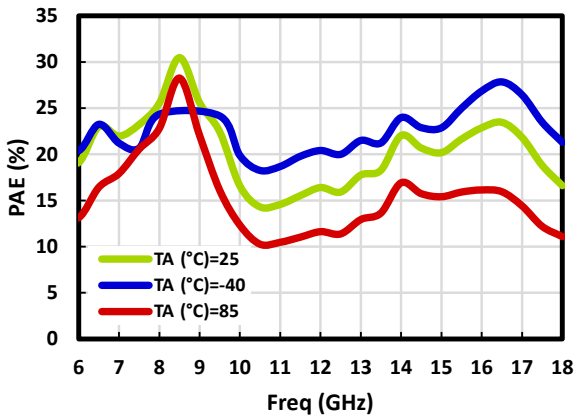

**Figure 1-31.** I<sub>d</sub> vs. Freq.

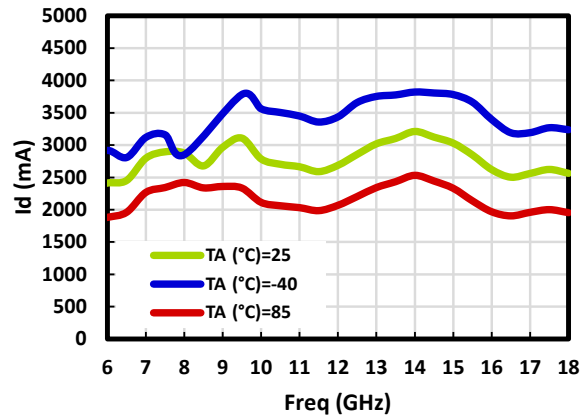

### Typical CW Linearity Power Data

Test conditions:  $V_D=24V$ ,  $I_{DQ}=280mA$ ,  $T_A=25^\circ C$ , CW

Figure 1-32.  $IM_3$  vs.  $P_{out}$

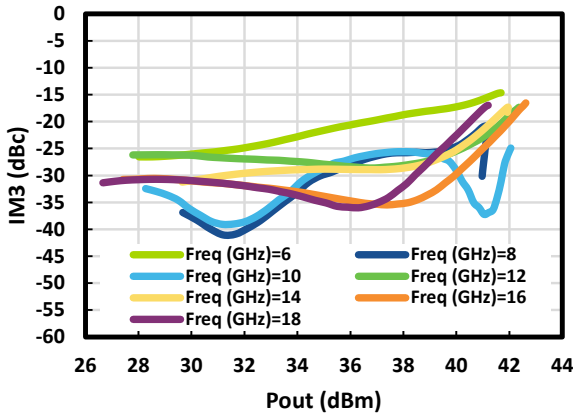
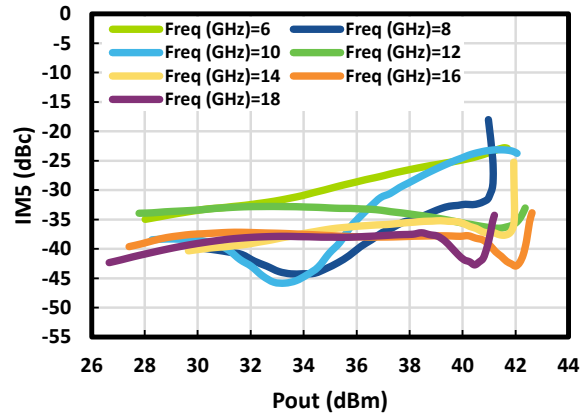
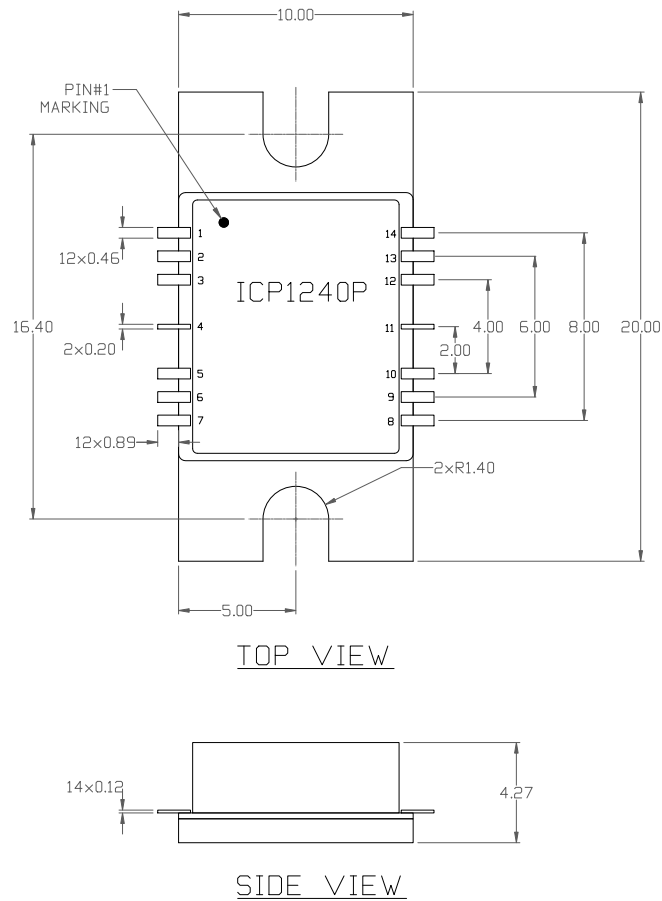

Figure 1-33.  $IM_5$  vs.  $P_{out}$



## 2. Mechanical Drawing



Units: mm

Pin No	Function	Description
1, 7	V <sub>G</sub>	Gate bias, decoupling and bypass caps required, bias must be applied to both pins.
2, 3, 5, 6, 9, 10, 12, 13	No connect	Pins can be connected to ground or left open circuit
4	RF <sub>IN</sub>	50Ω RF input. DC blocked
8, 14	V <sub>D</sub>	Drain bias, decoupling and bypass caps required, bias must be applied to both pins.
11	RF <sub>OUT</sub>	50Ω RF output. DC blocked
Flange	GND	RF and DC ground

### 3. Application Circuit

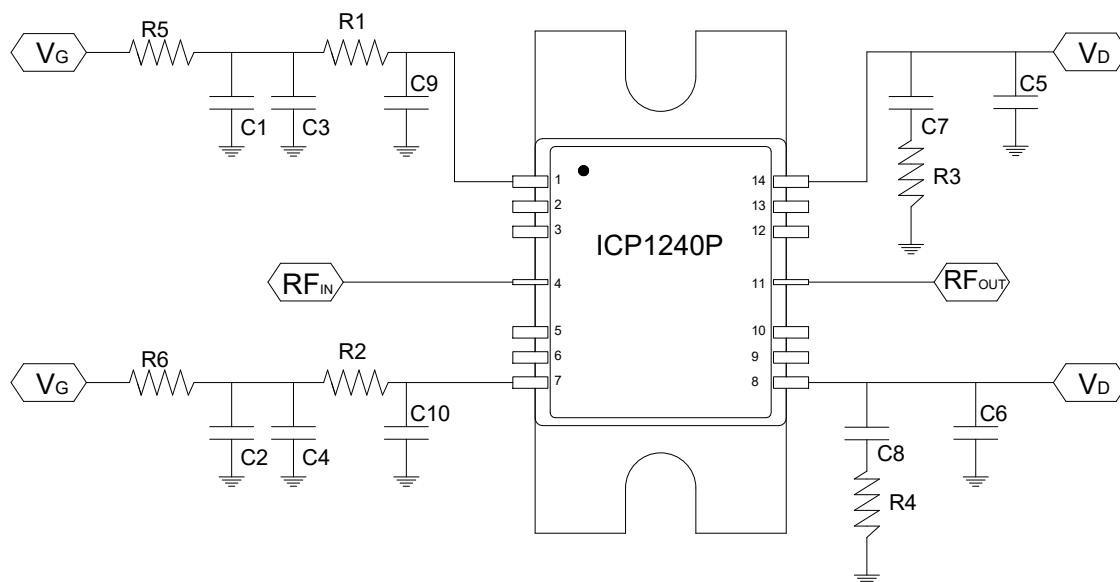

#### Bill of materials

Component ID	Value	Details	Manufacturer Part No.
C1, C2	10uF	10uF Capacitor, 10%, 35V, 1206	Various
C3-C6	1uF	1uF Capacitor, 10%, 35V, 0603	Various
C7, C8	10nF	10nF Capacitor, 10%, 50V, 0402	Various
C9, C10	100nF	100nF Capacitor, 10%, 35V, 0402	Various
R1, R2	5.1Ohm	5.1Ohm Resistor, 0402	Various
R3, R4	0Ohm	0Ohm Resistor, 0402	Various
R5, R6	56Ohm	56Ohm Resistor, wire in calbe	Various

## 4. Evaluation Board

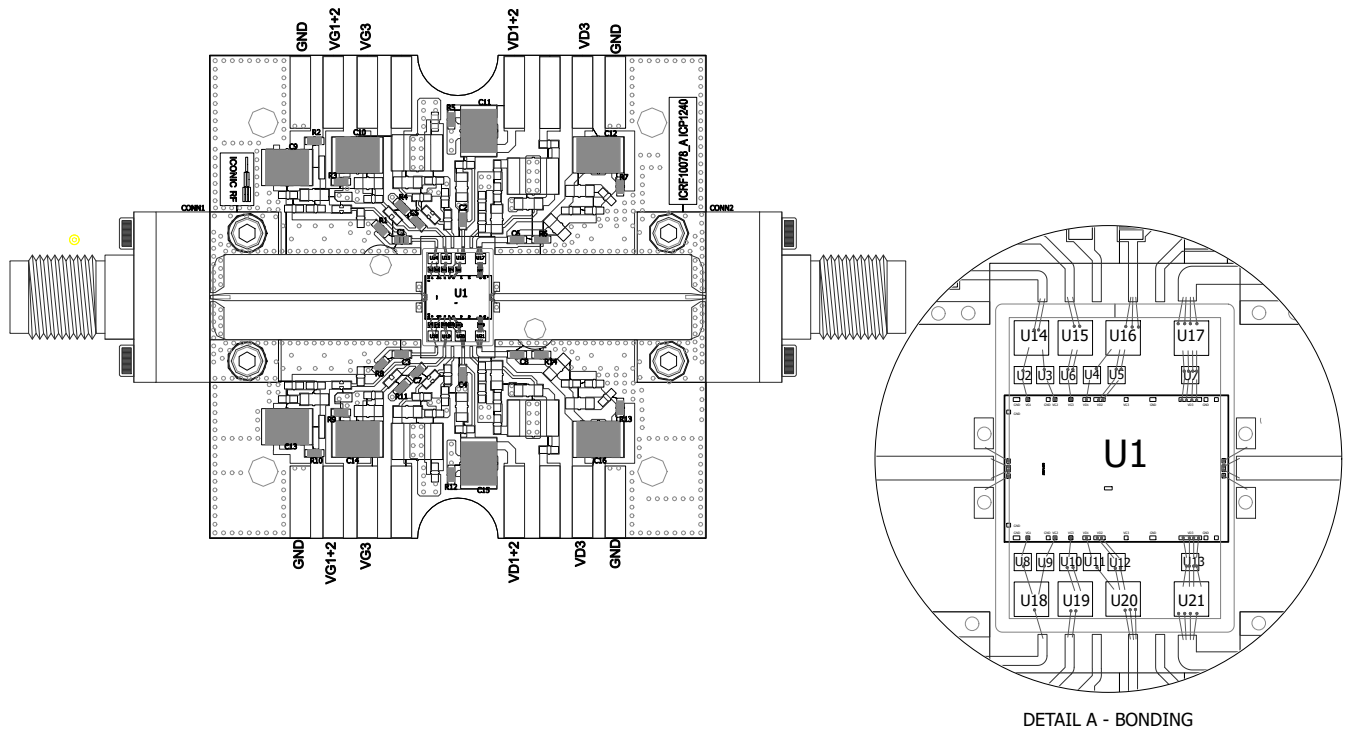

### PCB Fabrication

PCB Construction	Material	Dimensions
METAL_1_TOP	Cu + ENIG	0.5oz Cu plated Electroless Palladium 0.3µm Electroless Nickel 3-6µm
DIELECTRIC	RO4003C	8mils (203.2µm)
METAL_2_BOTTOM	Cu + ENIG	0.5oz Cu plated Electroless Palladium 0.3µm Electroless Nickel 3-6µm

Key Features	Dimensions
VIA Drill	0.3mm
VIA Plating Thickness	15µm
50Ohm LINE WIDTH	420µm

## 5. Other considerations

### Assembly Guidance

The package must be bolted to a thermally conductive base plate and the pins aligned with the PCB tracks. For optimum thermal transfer use an electrically conductive thermal compound before fixing the package.

### Solderability

Its recommended to manually solder the leads to the PCB using a no-clean solder. This avoids washing the part after soldering.

Components are compatible lead-free solder with a temperature of 260°C

For optimum RF and thermal performance IconicRF recommends the die assembly base plate is adequately bolted to an forced air heat sink using a thermal graphite interface pad (Graphite Interface Material GCSP-017-G 17µm thick) for optimal heat transfer.

There are many variables of the second level assembly between the die base plate and heat sink that IconicRF are unable to control and the following guidance is provided as information only. Fixing bolts should be provided as close to the die as possible to ensure a optimum pressure between the base plate and the heat sink.

The bolting screws used to attach the PCB assembly to the heat sink must include washers and be tightened with a suitable tightening pattern to ensure a uniform pressure. It is advised all surfaces be cleaned and be free of grease and dust prior to fully aligning the assembly with all screws located and tightened to finger tight. Further torquing of the screws must be achieved in multiple phases using a star shaped pattern to a recommended torque of 2.5N/m.

### Bias-up procedure

1. Set  $V_G$  to -5V
2. Set  $V_D$  to 20-24V
3. Adjust  $V_G$  positive until  $I_D$  quiescent is 280mA
4. Limit  $I_D$  to 4.5A
5. Apply RF signal

### Bias-down procedure

1. Turn off RF
2. Turn off  $V_D$ , allow drain capacitors to discharge
3. Turn off  $V_G$

## 6. Ordering, Shipping, and Handling

### Handling Recommendations

Integrated circuits are sensitive to electrostatic discharge (ESD) and can be damaged by static electricity. It is recommended to follow all procedures and guidelines outlined in the Microsemi application note AN01: GaAs MMIC Handling and Die Attach Recommendations.

### Ordering Information

For additional ordering information, contact your Microchip sales representative.

Part Number	Description
ICP1240-1-4511	Ceramic flange package
EV63E22A	Evaluation Board with SMA Connectors (ICP1240-1-4511 PCB Assembly)

## Microchip Information

### The Microchip Website

Microchip provides online support via our website at [www.microchip.com/](http://www.microchip.com/). This website is used to make files and information easily available to customers. Some of the content available includes:

- **Product Support** – Data sheets and errata, application notes and sample programs, design resources, user’s guides and hardware support documents, latest software releases and archived software
- **General Technical Support** – Frequently Asked Questions (FAQs), technical support requests, online discussion groups, Microchip design partner program member listing
- **Business of Microchip** – Product selector and ordering guides, latest Microchip press releases, listing of seminars and events, listings of Microchip sales offices, distributors and factory representatives

### Product Change Notification Service

Microchip’s product change notification service helps keep customers current on Microchip products. Subscribers will receive email notification whenever there are changes, updates, revisions or errata related to a specified product family or development tool of interest.

To register, go to [www.microchip.com/pcn](http://www.microchip.com/pcn) and follow the registration instructions.

### Customer Support

Users of Microchip products can receive assistance through several channels:

- Distributor or Representative
- Local Sales Office
- Embedded Solutions Engineer (ESE)
- Technical Support

Customers should contact their distributor, representative or ESE for support. Local sales offices are also available to help customers. A listing of sales offices and locations is included in this document.

Technical support is available through the website at: [www.microchip.com/support](http://www.microchip.com/support)

### Microchip Devices Code Protection Feature

Note the following details of the code protection feature on Microchip products:

- Microchip products meet the specifications contained in their particular Microchip Data Sheet.
- Microchip believes that its family of products is secure when used in the intended manner, within operating specifications, and under normal conditions.
- Microchip values and aggressively protects its intellectual property rights. Attempts to breach the code protection features of Microchip product is strictly prohibited and may violate the Digital Millennium Copyright Act.
- Neither Microchip nor any other semiconductor manufacturer can guarantee the security of its code. Code protection does not mean that we are guaranteeing the product is “unbreakable”. Code protection is constantly evolving. Microchip is committed to continuously improving the code protection features of our products.

### Legal Notice

This publication and the information herein may be used only with Microchip products, including to design, test, and integrate Microchip products with your application. Use of this information in any other manner violates these terms. Information regarding device applications is provided only for your convenience and may be superseded by updates. It is your responsibility to ensure

that your application meets with your specifications. Contact your local Microchip sales office for additional support or, obtain additional support at [www.microchip.com/en-us/support/design-help/client-support-services](http://www.microchip.com/en-us/support/design-help/client-support-services).

THIS INFORMATION IS PROVIDED BY MICROCHIP "AS IS". MICROCHIP MAKES NO REPRESENTATIONS OR WARRANTIES OF ANY KIND WHETHER EXPRESS OR IMPLIED, WRITTEN OR ORAL, STATUTORY OR OTHERWISE, RELATED TO THE INFORMATION INCLUDING BUT NOT LIMITED TO ANY IMPLIED WARRANTIES OF NON-INFRINGEMENT, MERCHANTABILITY, AND FITNESS FOR A PARTICULAR PURPOSE, OR WARRANTIES RELATED TO ITS CONDITION, QUALITY, OR PERFORMANCE.

IN NO EVENT WILL MICROCHIP BE LIABLE FOR ANY INDIRECT, SPECIAL, PUNITIVE, INCIDENTAL, OR CONSEQUENTIAL LOSS, DAMAGE, COST, OR EXPENSE OF ANY KIND WHATSOEVER RELATED TO THE INFORMATION OR ITS USE, HOWEVER CAUSED, EVEN IF MICROCHIP HAS BEEN ADVISED OF THE POSSIBILITY OR THE DAMAGES ARE FORESEEABLE. TO THE FULLEST EXTENT ALLOWED BY LAW, MICROCHIP'S TOTAL LIABILITY ON ALL CLAIMS IN ANY WAY RELATED TO THE INFORMATION OR ITS USE WILL NOT EXCEED THE AMOUNT OF FEES, IF ANY, THAT YOU HAVE PAID DIRECTLY TO MICROCHIP FOR THE INFORMATION.

Use of Microchip devices in life support and/or safety applications is entirely at the buyer's risk, and the buyer agrees to defend, indemnify and hold harmless Microchip from any and all damages, claims, suits, or expenses resulting from such use. No licenses are conveyed, implicitly or otherwise, under any Microchip intellectual property rights unless otherwise stated.

## Trademarks

The Microchip name and logo, the Microchip logo, Adaptec, AVR, AVR logo, AVR Freaks, BesTime, BitCloud, CryptoMemory, CryptoRF, dsPIC, flexPWR, HELDO, IGLOO, JukeBlox, KeeLoq, Kleer, LANCheck, LinkMD, maXStylus, maXTouch, MediaLB, megaAVR, Microsemi, Microsemi logo, MOST, MOST logo, MPLAB, OptoLyzer, PIC, picoPower, PICSTART, PIC32 logo, PolarFire, Prochip Designer, QTouch, SAM-BA, SenGenuity, SpyNIC, SST, SST Logo, SuperFlash, Symmetricom, SyncServer, Tachyon, TimeSource, tinyAVR, UNI/O, Vectron, and XMEGA are registered trademarks of Microchip Technology Incorporated in the U.S.A. and other countries.

AgileSwitch, ClockWorks, The Embedded Control Solutions Company, EtherSynch, Flashtec, Hyper Speed Control, HyperLight Load, Libero, motorBench, mTouch, Powermite 3, Precision Edge, ProASIC, ProASIC Plus, ProASIC Plus logo, Quiet-Wire, SmartFusion, SyncWorld, TimeCesium, TimeHub, TimePictra, TimeProvider, and ZL are registered trademarks of Microchip Technology Incorporated in the U.S.A.

Adjacent Key Suppression, AKS, Analog-for-the-Digital Age, Any Capacitor, AnyIn, AnyOut, Augmented Switching, BlueSky, BodyCom, Clockstudio, CodeGuard, CryptoAuthentication, CryptoAutomotive, CryptoCompanion, CryptoController, dsPICDEM, dsPICDEM.net, Dynamic Average Matching, DAM, ECAN, Espresso T1S, EtherGREEN, EyeOpen, GridTime, IdealBridge, IGaT, In-Circuit Serial Programming, ICSP, INICnet, Intelligent Paralleling, IntelliMOS, Inter-Chip Connectivity, JitterBlocker, Knob-on-Display, MarginLink, maxCrypto, maxView, memBrain, Mindi, MiWi, MPASM, MPF, MPLAB Certified logo, MPLIB, MPLINK, mSiC, MultiTRAK, NetDetach, Omniscient Code Generation, PICDEM, PICDEM.net, PICkit, PICTail, Power MOS IV, Power MOS 7, PowerSmart, PureSilicon, QMatrix, REAL ICE, Ripple Blocker, RTAX, RTG4, SAM-ICE, Serial Quad I/O, simpleMAP, SimpliPHY, SmartBuffer, SmartHLS, SMART-I.S., storClad, SQI, SuperSwitcher, SuperSwitcher II, Switchtec, SynchroPHY, Total Endurance, Trusted Time, TSHARC, Turing, USBCheck, VariSense, VectorBlox, VeriPHY, ViewSpan, WiperLock, XpressConnect, and ZENA are trademarks of Microchip Technology Incorporated in the U.S.A. and other countries.

SQTP is a service mark of Microchip Technology Incorporated in the U.S.A.

The Adaptec logo, Frequency on Demand, Silicon Storage Technology, and Symmcom are registered trademarks of Microchip Technology Inc. in other countries.

GestIC is a registered trademark of Microchip Technology Germany II GmbH & Co. KG, a subsidiary of Microchip Technology Inc., in other countries.

All other trademarks mentioned herein are property of their respective companies.

© 2024, Microchip Technology Incorporated and its subsidiaries. All Rights Reserved.

ISBN:

AMBA, Arm, Arm7, Arm7TDMI, Arm9, Arm11, Artisan, big.LITTLE, Cordio, CoreLink, CoreSight, Cortex, DesignStart, DynamIQ, Jazelle, Keil, Mali, Mbed, Mbed Enabled, NEON, POP, RealView, SecurCore, Socrates, Thumb, TrustZone, ULINK, ULINK2, ULINK-ME, ULINK-PLUS, ULINKpro,  $\mu$ Vision, Versatile are trademarks or registered trademarks of Arm Limited (or its subsidiaries) in the US and/or elsewhere.

## Quality Management System

For information regarding Microchip's Quality Management Systems, please visit [www.microchip.com/quality](http://www.microchip.com/quality).

# Worldwide Sales and Service

AMERICAS	ASIA/PACIFIC	ASIA/PACIFIC	EUROPE
<p><b>Corporate Office</b> 2355 West Chandler Blvd. Chandler, AZ 85224-6199 Tel: 480-792-7200 Fax: 480-792-7277 Technical Support: <a href="http://www.microchip.com/support">www.microchip.com/support</a> Web Address: <a href="http://www.microchip.com">www.microchip.com</a></p> <p><b>Atlanta</b> Duluth, GA Tel: 678-957-9614 Fax: 678-957-1455</p> <p><b>Austin, TX</b> Tel: 512-257-3370</p> <p><b>Boston</b> Westborough, MA Tel: 774-760-0087 Fax: 774-760-0088</p> <p><b>Chicago</b> Itasca, IL Tel: 630-285-0071 Fax: 630-285-0075</p> <p><b>Dallas</b> Addison, TX Tel: 972-818-7423 Fax: 972-818-2924</p> <p><b>Detroit</b> Novi, MI Tel: 248-848-4000</p> <p><b>Houston, TX</b> Tel: 281-894-5983</p> <p><b>Indianapolis</b> Noblesville, IN Tel: 317-773-8323 Fax: 317-773-5453 Tel: 317-536-2380</p> <p><b>Los Angeles</b> Mission Viejo, CA Tel: 949-462-9523 Fax: 949-462-9608 Tel: 951-273-7800</p> <p><b>Raleigh, NC</b> Tel: 919-844-7510</p> <p><b>New York, NY</b> Tel: 631-435-6000</p> <p><b>San Jose, CA</b> Tel: 408-735-9110 Tel: 408-436-4270</p> <p><b>Canada - Toronto</b> Tel: 905-695-1980 Fax: 905-695-2078</p>	<p><b>Australia - Sydney</b> Tel: 61-2-9868-6733</p> <p><b>China - Beijing</b> Tel: 86-10-8569-7000</p> <p><b>China - Chengdu</b> Tel: 86-28-8665-5511</p> <p><b>China - Chongqing</b> Tel: 86-23-8980-9588</p> <p><b>China - Dongguan</b> Tel: 86-769-8702-9880</p> <p><b>China - Guangzhou</b> Tel: 86-20-8755-8029</p> <p><b>China - Hangzhou</b> Tel: 86-571-8792-8115</p> <p><b>China - Hong Kong SAR</b> Tel: 852-2943-5100</p> <p><b>China - Nanjing</b> Tel: 86-25-8473-2460</p> <p><b>China - Qingdao</b> Tel: 86-532-8502-7355</p> <p><b>China - Shanghai</b> Tel: 86-21-3326-8000</p> <p><b>China - Shenyang</b> Tel: 86-24-2334-2829</p> <p><b>China - Shenzhen</b> Tel: 86-755-8864-2200</p> <p><b>China - Suzhou</b> Tel: 86-186-6233-1526</p> <p><b>China - Wuhan</b> Tel: 86-27-5980-5300</p> <p><b>China - Xian</b> Tel: 86-29-8833-7252</p> <p><b>China - Xiamen</b> Tel: 86-592-2388138</p> <p><b>China - Zhuhai</b> Tel: 86-756-3210040</p>	<p><b>India - Bangalore</b> Tel: 91-80-3090-4444</p> <p><b>India - New Delhi</b> Tel: 91-11-4160-8631</p> <p><b>India - Pune</b> Tel: 91-20-4121-0141</p> <p><b>Japan - Osaka</b> Tel: 81-6-6152-7160</p> <p><b>Japan - Tokyo</b> Tel: 81-3-6880-3770</p> <p><b>Korea - Daegu</b> Tel: 82-53-744-4301</p> <p><b>Korea - Seoul</b> Tel: 82-2-554-7200</p> <p><b>Malaysia - Kuala Lumpur</b> Tel: 60-3-7651-7906</p> <p><b>Malaysia - Penang</b> Tel: 60-4-227-8870</p> <p><b>Philippines - Manila</b> Tel: 63-2-634-9065</p> <p><b>Singapore</b> Tel: 65-6334-8870</p> <p><b>Taiwan - Hsin Chu</b> Tel: 886-3-577-8366</p> <p><b>Taiwan - Kaohsiung</b> Tel: 886-7-213-7830</p> <p><b>Taiwan - Taipei</b> Tel: 886-2-2508-8600</p> <p><b>Thailand - Bangkok</b> Tel: 66-2-694-1351</p> <p><b>Vietnam - Ho Chi Minh</b> Tel: 84-28-5448-2100</p>	<p><b>Austria - Wels</b> Tel: 43-7242-2244-39 Fax: 43-7242-2244-393</p> <p><b>Denmark - Copenhagen</b> Tel: 45-4485-5910 Fax: 45-4485-2829</p> <p><b>Finland - Espoo</b> Tel: 358-9-4520-820</p> <p><b>France - Paris</b> Tel: 33-1-69-53-63-20 Fax: 33-1-69-30-90-79</p> <p><b>Germany - Garching</b> Tel: 49-8931-9700</p> <p><b>Germany - Haan</b> Tel: 49-2129-3766400</p> <p><b>Germany - Heilbronn</b> Tel: 49-7131-72400</p> <p><b>Germany - Karlsruhe</b> Tel: 49-721-625370</p> <p><b>Germany - Munich</b> Tel: 49-89-627-144-0 Fax: 49-89-627-144-44</p> <p><b>Germany - Rosenheim</b> Tel: 49-8031-354-560</p> <p><b>Israel - Ra'anana</b> Tel: 972-9-744-7705</p> <p><b>Italy - Milan</b> Tel: 39-0331-742611 Fax: 39-0331-466781</p> <p><b>Italy - Padova</b> Tel: 39-049-7625286</p> <p><b>Netherlands - Drunen</b> Tel: 31-416-690399 Fax: 31-416-690340</p> <p><b>Norway - Trondheim</b> Tel: 47-72884388</p> <p><b>Poland - Warsaw</b> Tel: 48-22-3325737</p> <p><b>Romania - Bucharest</b> Tel: 40-21-407-87-50</p> <p><b>Spain - Madrid</b> Tel: 34-91-708-08-90 Fax: 34-91-708-08-91</p> <p><b>Sweden - Gothenberg</b> Tel: 46-31-704-60-40</p> <p><b>Sweden - Stockholm</b> Tel: 46-8-5090-4654</p> <p><b>UK - Wokingham</b> Tel: 44-118-921-5800 Fax: 44-118-921-5820</p>