

Microchip

Filter specification

TFS135E

1/5

Measurement condition

Ambient temperature: 23 °C
 Input power level: 0 dBm
 Terminating impedance: *
 Input: 630 Ω || -1,2 pF
 Output: 630 Ω || -1,2 pF

Characteristics

Remark:

The reference level for the relative attenuation a_{rel} of the TFS135E is the minimum of the pass band attenuation. This value is defined as the insertion loss a_e . The nominal frequency f_N is fixed at 135,53 MHz without any tolerance. The frequency shift of the filter in the operating temperature range is not included in the production tolerance scheme. But values of relative attenuation are guardbanded to compensate for the difference of frequency shift over temperature at the limits of the operating temperature range between a device with typical frequency inversion temperature and devices at the limits of frequency inversion temperature.

| D a t a | | typ. value | | tolerance / limit | |
|---|-----------------------|-------------|---------------------------|--------------------|------------|
| Insertion loss (reference level) | | a_e | 4,8 dB | max. | 5,3 dB |
| Nominal frequency | | f_N | - | | 135,53 MHz |
| Passband | | PB | - | $f_N \pm 13$ | kHz |
| Pass band ripple | | p-p | 1,0 dB | max. | 3,0 dB |
| Bandwidth | | BW | | | |
| 1 | dB | | 49 kHz | min. | 41 kHz |
| 3 | dB | | 58 kHz | min. | 47 kHz |
| 40 | dB | | 174 kHz | max. | 219 kHz |
| Relative attenuation | | a_{rel} | | | |
| f_N | ... $f_N \pm 13$ kHz | | 1,0 dB | max. | 3 dB |
| $f_N \pm 60$ kHz | ... $f_N \pm 120$ kHz | | 19 dB | min. | 14 dB |
| $f_N \pm 120$ kHz | ... $f_N \pm 240$ kHz | | 45 dB | min. | 40 dB |
| $f_N \pm 240$ kHz | ... $f_N \pm 1$ MHz | | 62 dB | min. | 50 dB |
| $f_N \pm 330$ kHz | | | 75 dB | min. | 55 dB |
| $f_N \pm 660$ kHz | | | 77 dB | min. | 55 dB |
| Group delay ripple within PB | | p-p | 6,2 μs | max. | 10 μs |
| Input power level | | | - | max. | 10 dBm |
| Permissible DC voltage | | | - | max. | 13 V |
| Operating temperature range | | OTR | - | - 30 °C ... + 85°C | |
| Storage temperature range | | | - | - 40 °C ... + 85°C | |
| Frequency inversion temperature | | | 27,8 °C | min. | 21,8 °C |
| | | | | max. | 33,8 °C |
| Temperature coefficient of frequency | | TC_f^{**} | -0,039 ppm/K ² | | - |

*) The terminating impedances depend on parasitics and q-values of matching elements and the board used, and are to be understood as reference values only. Should there be additional questions do not hesitate to ask for an application note or contact our design team.

**) $\Delta f(\text{Hz}) = TC_f(\text{ppm/K}^2) \times (T - T_0)^2 \times f_{T0}(\text{MHz})$.

Generated:

Checked / Approved:

Filter characteristic

Microchip Frequency Technology GmbH
Potsdamer Straße 18
D 14 513 TELTOW / Germany
Tel: (+49) 3328 4784-0 / Fax: (+49) 3328 4784-30

Microchip Frequency Technology GmbH reserves the right to make changes to the product(s) and/or information contained herein without notice. No liability is assumed as a result of their use or application. No rights under any patent accompany the sale of any such product(s) or information.

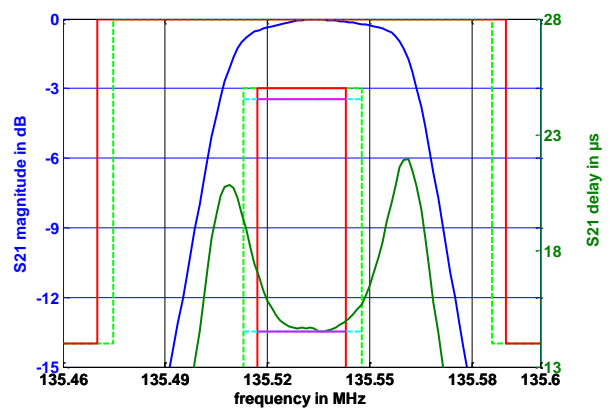
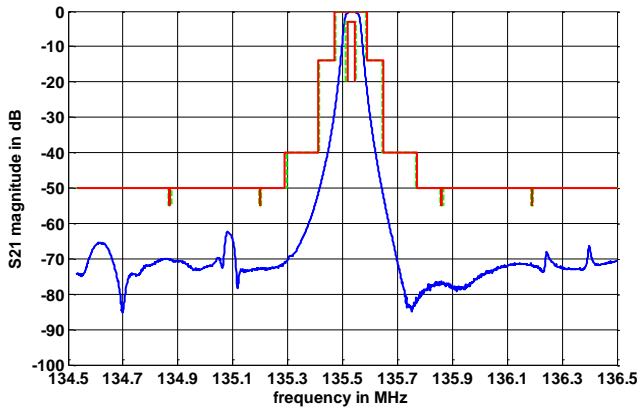

Construction and pin connection

(All dimensions in mm)

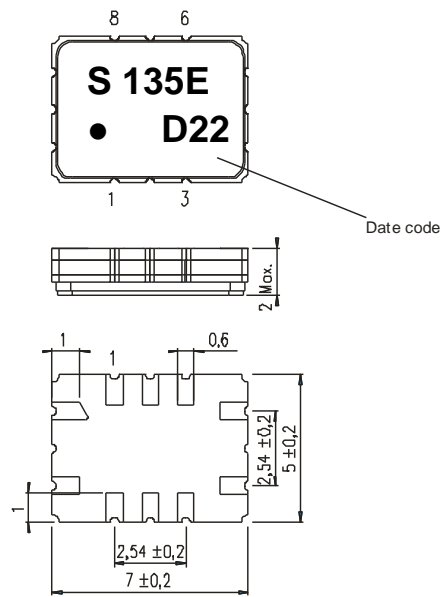

- 1 Ground
- 2 Ground
- 3 Ground
- 4 Output RF Return
- 5 Output
- 6 Ground
- 7 Ground
- 8 Ground
- 9 Input RF Return
- 10 Input

Date code: Year + week
 D 2013
 E 2014
 F 2015
 ...

50 Ohm test circuit

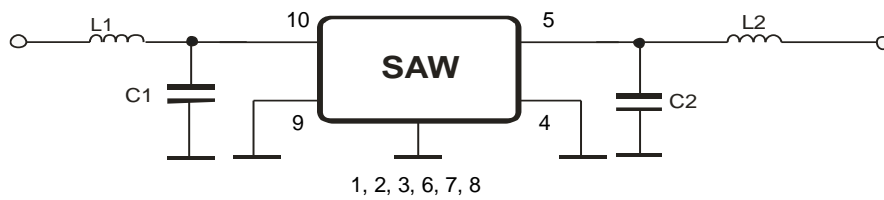

Microchip Frequency Technology GmbH
 Potsdamer Straße 18
 D 14 513 TELTOW / Germany
 Tel: (+49) 3328 4784-0 / Fax: (+49) 3328 4784-30

Microchip Frequency Technology GmbH reserves the right to make changes to the product(s) and/or information contained herein without notice. No liability is assumed as a result of their use or application. No rights under any patent accompany the sale of any such product(s) or information.

Stability characteristics, reliability

After the following tests the filter shall meet the whole specification:

1. Shock: 500g, 1 ms, half sine wave, 3 shocks each plane;
DIN IEC 68 T2 - 27
2. Vibration: 10 Hz to 500 Hz, 0,35 mm or 5 g respectively, 1 octave per min, 10 cycles per plan, 3 plans;
DIN IEC 68 T2 - 6
3. Change of temperature: -55 °C to 125°C / 15 min. each / 100 cycles
DIN IEC 68 part 2 – 14 Test N
4. Resistance to solder heat (reflow): reflow possible: three times max.;
for temperature conditions refer to the attached "Air reflow temperature conditions" on page 4;

This filter is RoHS compliant (2011/65/EU)

Packing

Tape & Reel: IEC 286 – 3, with exception of value for N and minimum bending radius;
tape type II, embossed carrier tape with top cover tape on the upper side;

| | |
|---|-------------|
| max. pieces of filters per reel: | 3000 |
| reel of empty components at start: | min. 300 mm |
| reel of empty components at start including leader: | min. 500 mm |
| trailer: | min. 300 mm |

Tape (all dimensions in mm)

- W : 16,00 ± 0,3
- Po : 4,00 ± 0,1
- Do : 1,50 +0,1/-0
- E : 1,75 ± 0,1
- F : 7,50 ± 0,1
- G(min) : 0,60
- P2 : 2,00 ± 0,1
- P1 : 8,00 ± 0,1
- D1(min) : 1,50
- Ao : 5,50 ± 0,1
- Bo : 7,50 ± 0,1
- Ct : 13,5 ± 0,1

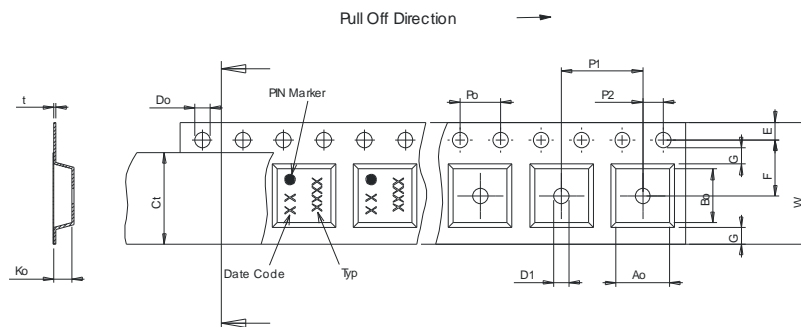

Reel (all dimensions in mm)

- A : 330
- W1 : 16,4 +2/-0
- W2(max) : 22,4
- N(min) : 50
- C : 13,0 +0,5/-0,2

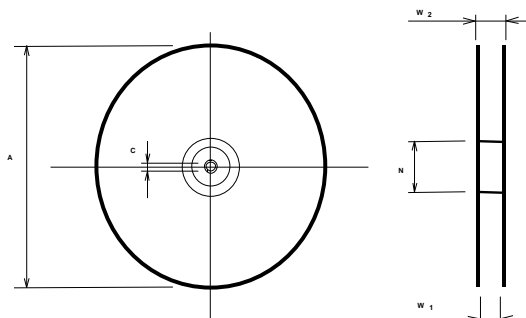

The minimum bending radius is 45 mm.

Microchip Frequency Technology GmbH
Potsdamer Straße 18
D 14 513 TELTOW / Germany
Tel: (+49) 3328 4784-0 / Fax: (+49) 3328 4784-30

Microchip Frequency Technology GmbH reserves the right to make changes to the product(s) and/or information contained herein without notice. No liability is assumed as a result of their use or application. No rights under any patent accompany the sale of any such product(s) or information.

Air reflow temperature conditions

| Conditions | Exposure |
|--|-----------------------------|
| Average ramp-up rate (30°C to 217°C) | less than 3°C/second |
| > 100°C | between 300 and 600 seconds |
| > 150°C | between 240 and 500 seconds |
| > 217°C | between 30 and 150 seconds |
| Peak temperature | max. 260°C |
| Time within 5°C of actual peak temperature | between 10 and 30 seconds |
| Cool-down rate (Peak to 50°C) | less than 6°C/second |
| Time from 30°C to Peak temperature | no greater than 300 seconds |

Chip-mount air reflow profile

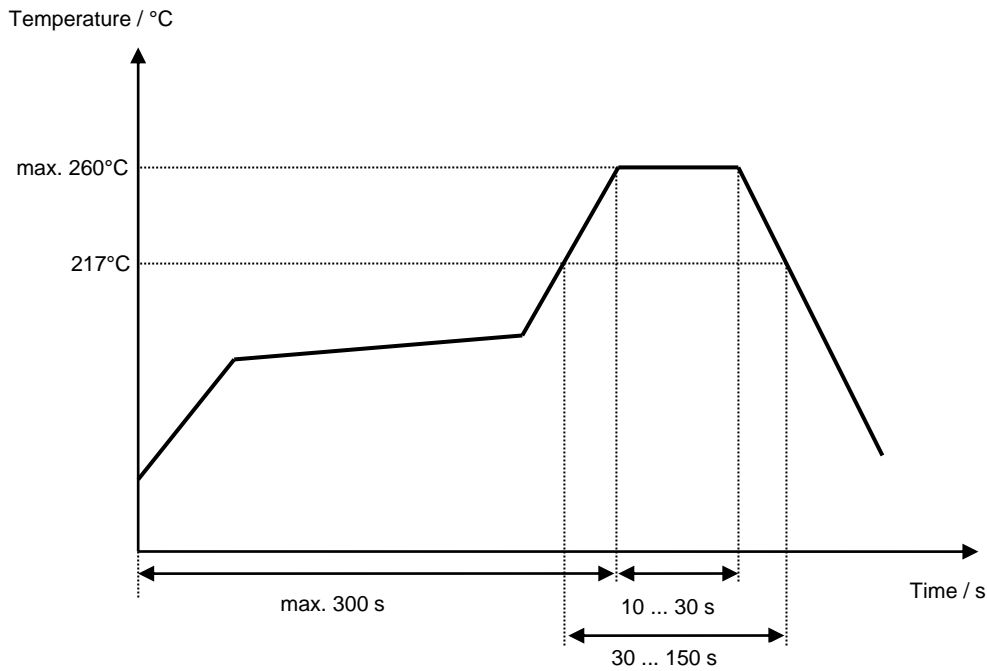

Microchip Frequency Technology GmbH
Potsdamer Straße 18
D 14 513 TELTOW / Germany
Tel: (+49) 3328 4784-0 / Fax: (+49) 3328 4784-30

Microchip Frequency Technology GmbH reserves the right to make changes to the product(s) and/or information contained herein without notice. No liability is assumed as a result of their use or application. No rights under any patent accompany the sale of any such product(s) or information.

Microchip**Filter specification****TFS135E****5/5****History**

| Version | Reason of Changes | Name | Date |
|----------------|--|-------------|-------------|
| 1.0 | - Generation of development specification | Strehl | 25.07.2007 |
| 1.1 | - Change f_N | Strehl | 27.07.2007 |
| 1.2 | - Add typ. value, filter characteristic and 50 Ohm test circuit - Generation of filter specification | Strehl | 04.09.2007 |
| 2.0 | - Added bandwidth values in to the data table | Raura | 15.05.2012 |
| 3.0 | - Changed pin marker position in Tape & Reel | Raura | 04.01.2013 |
| 4.0 | - Reduce pass band width | Dr. Wall | 26.04.2013 |
| 5.0 | - Skip modificatons from specification version 4.0 - Intensify guaranteed parameters of parameters of "change of temperature" in chapter "stability characteristics, reliability" - Change RoHS norm in chapter "stability characteristics, reliability" - Change turn over temperature - Change temperature coefficient of frequency - Remove 1 dB amplitude ripple from specification - Change remark (way of quadbanding for frequency shift over temperature) - Limit lines in "filter characteristic" adjusted | Dr. Wall | 11.06.2013 |

Microchip Frequency Technology GmbH
Potsdamer Straße 18
D 14 513 TELTOW / Germany
Tel: (+49) 3328 4784-0 / Fax: (+49) 3328 4784-30

Microchip Frequency Technology GmbH reserves the right to make changes to the product(s) and/or information contained herein without notice. No liability is assumed as a result of their use or application. No rights under any patent accompany the sale of any such product(s) or information.