

Microchip	Filter specification	TFS1220C	1/5
------------------	-----------------------------	-----------------	------------

Measurement condition

Ambient temperature T_A : 23 °C
 Input power level: 0 dBm

Terminating impedance:

Input: 200 Ω
 Output: 200 Ω

Characteristics

Remark:

The reference level for the relative attenuation a_{rel} of TFS1220C is the minimum of the passband attenuation a_{min} . This value is defined as the insertion loss a_e . The centre frequency f_C is the arithmetic mean value of the upper and lower frequencies at the 3 dB filter attenuation level relative to the insertion loss a_e . The given values for the relative attenuation a_{rel} and the group delay ripple have to be reached at the frequencies given below, even if the centre frequency f_C is shifted due to the temperature coefficient of frequency TC_f in the operating temperature range and due to a production tolerance for the centre frequency f_C .

D a t a		typ. value		tolerance / limit		
Insertion loss	a_e	1.9	dB	max.	5.8	dB
(reference level)						
Nominal frequency	f_N	-		1220		MHz
Centre frequency at ambient temperature	f_C	-		1220 ± 2		MHz
Passband	PB			f_C ± 4		MHz
Passband ripple		0.7	dB	max.	1.5	dB
Bandwidth	BW					
1.5 dB		25	MHz	min.	8	MHz
Relative attenuation	a_{rel}					
f_C - 4 MHz ... f_C + 4 MHz		0.7	dB	max.	1.5	dB
f_C - 36 MHz		52	dB	min.	40.2	dB
f_C - 44 MHz		55	dB	min.	44.2	dB
f_C - 72 MHz		62	dB	min.	42.0	dB
f_C - 88 MHz		53	dB	min.	44.2	dB
f_C - 68 MHz ... f_C - 76 MHz		53	dB	min.	40.2	dB
f_C - 76 MHz ... f_C - 85 MHz		53	dB	min.	44.2	dB
f_C - 85 MHz ... f_C - 91 MHz		52	dB	min.	44.2	dB
f_C - 91 MHz ... f_C - 720 MHz		51	dB	min.	44.2	dB
f_C + 70 MHz ... f_C + 780 MHz		57	dB	min.	44.2	dB
Group delay ripple **						
f_C - 4 MHz ... f_C + 4 MHz		4	ns	max.	15	ns
Operating temperature range	OTR	-		- 30 °C ... + 80 °C		
Storage temperature range		-		- 40 °C ... + 85 °C		
Temperature coefficient of frequency	TC_f ***	- 37	ppm/K			

*) The terminating impedances depend on parasitics and q-values of matching elements and the board used, and are to be understood as reference values only. Should there be additional questions do not hesitate to ask for an application note or contact our design team.

**) Aperture 500 kHz

***) $\Delta f = TC_f(T - T_A)f_N$

Generated:

Checked / Approved:

Microchip Frequency Technology GmbH
Potsdamer Straße 18
D 14 513 TELTOW / Germany
Tel: (+49) 3328 4784-0 / Fax: (+49) 3328 4784-30

Microchip Frequency Technology GmbH reserves the right to make changes to the product(s) and/or information contained herein without notice. No liability is assumed as a result of their use or application. No rights under any patent accompany the sale of any such product(s) or information.

Filter characteristic

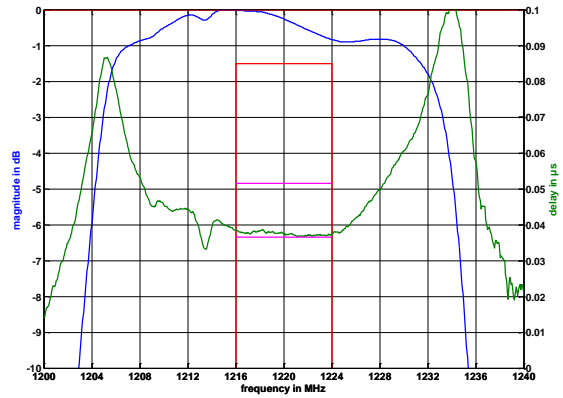
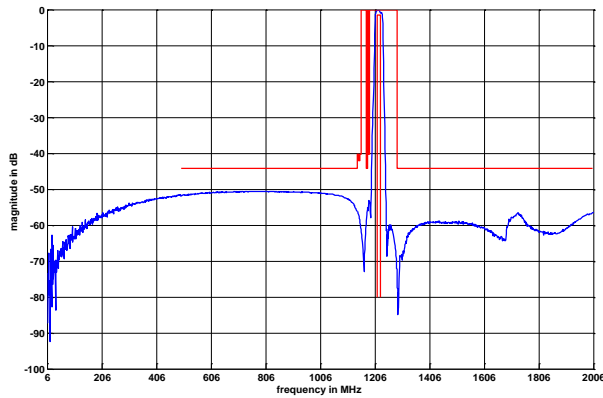

Construction and pin connection

(All dimensions in mm)

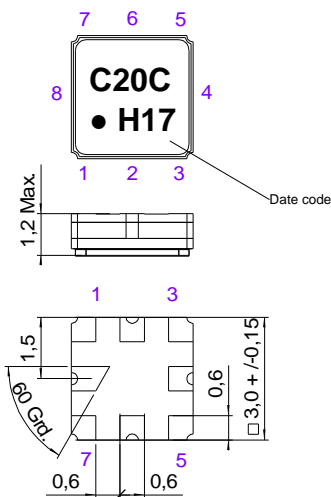

- 1 Input
- 2 Input
- 3 Ground
- 4 Ground
- 5 Output
- 6 Output
- 7 Ground
- 8 Ground

Date code: Year + week
 H 2016
 J 2017
 K 2018
 ...

200 Ω Test circuit

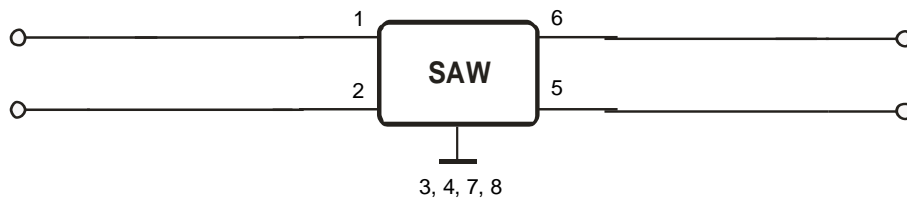

Microchip Frequency Technology GmbH
 Potsdamer Straße 18
 D 14 513 TELTOW / Germany
 Tel: (+49) 3328 4784-0 / Fax: (+49) 3328 4784-30

Microchip Frequency Technology GmbH reserves the right to make changes to the product(s) and/or information contained herein without notice. No liability is assumed as a result of their use or application. No rights under any patent accompany the sale of any such product(s) or information.

Stability characteristics, reliability

After the following tests the filter shall meet the whole specification:

1. Shock: 500 g, 1 ms, half sine wave, 3 shocks each plane;
DIN IEC 60068 T2 - 27
2. Vibration: 10 Hz to 2000 Hz, 0.35 mm or 5 g respectively, 1 octave per min, 10 cycles per plane, 3 planes; DIN IEC 60068 T2 - 6
3. Change of temperature: -55 °C to 125 °C / 15 min. each / 100 cycles
DIN IEC 60068 part 2 – 14 Test N
4. Resistance to solder heat (reflow): reflow possible: three times max.;
for temperature conditions, see page 4: "Air reflow temperature conditions"
5. ESD SAW devices are electrostatic discharge (ESD) sensitive devices

This filter is RoHS compliant (2011/65/EU)

Packing

Tape & Reel: IEC 286 – 3, with exception of value for N and minimum bending radius;
tape type II, embossed carrier tape with top cover tape on the upper side;

max. pieces of filters per reel:	3000
reel of empty components at start:	min. 300 mm
reel of empty components at start including leader:	min. 500 mm
trailer:	min. 300 mm

Tape (all dimensions in mm)

- W : 8.00 ± 0.3
- Po : 4.00 ± 0.1
- Do : 1.50 +0.1/-0
- E : 1.75 ± 0.1
- F : 3.50 ± 0.05
- G(min) : 0.75
- P2 : 2.00 ± 0.05
- P1 : 4.00 ± 0.1
- D1(min) : 1.50
- Ao : 3.25 ± 0.1
- Bo : 3.25 ± 0.1
- Ct : 5.3 ± 0.1

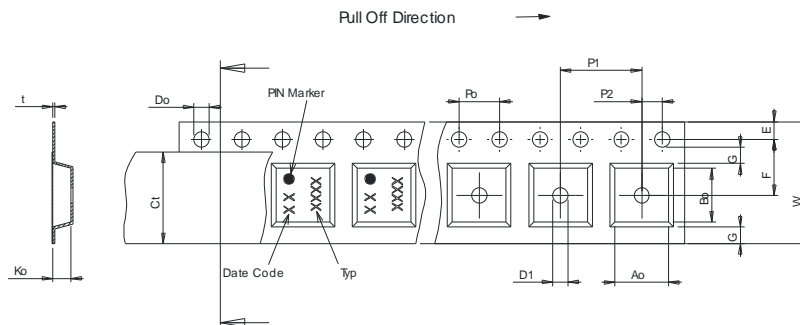

Reel (all dimensions in mm)

- A : 330 or 180
- W1 : 8.4 +1.5/-0
- W2(max) : 14.4
- N(min) : 60
- C : 13.0 ± 0.2

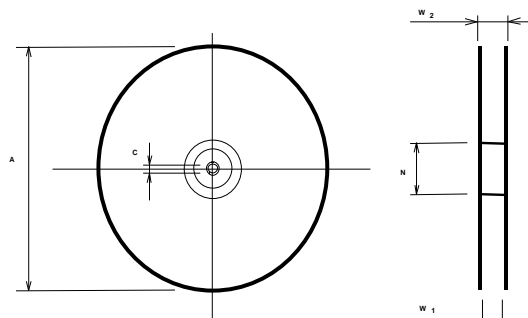

The minimum bending radius is 45 mm.

Microchip Frequency Technology GmbH
Potsdamer Straße 18
D 14 513 TELTOW / Germany
Tel: (+49) 3328 4784-0 / Fax: (+49) 3328 4784-30

Microchip Frequency Technology GmbH reserves the right to make changes to the product(s) and/or information contained herein without notice. No liability is assumed as a result of their use or application. No rights under any patent accompany the sale of any such product(s) or information.

Air reflow temperature conditions

Conditions	Exposure
Average ramp-up rate (30°C to 217°C)	less than 3°C/second
> 100°C	between 300 and 600 seconds
> 150°C	between 240 and 500 seconds
> 217°C	between 30 and 150 seconds
Peak temperature	max. 260°C
Time within 5°C of actual peak temperature	between 10 and 30 seconds
Cool-down rate (Peak to 50°C)	less than 6°C/second
Time from 30°C to Peak temperature	no greater than 300 seconds

Chip-mount air reflow profile

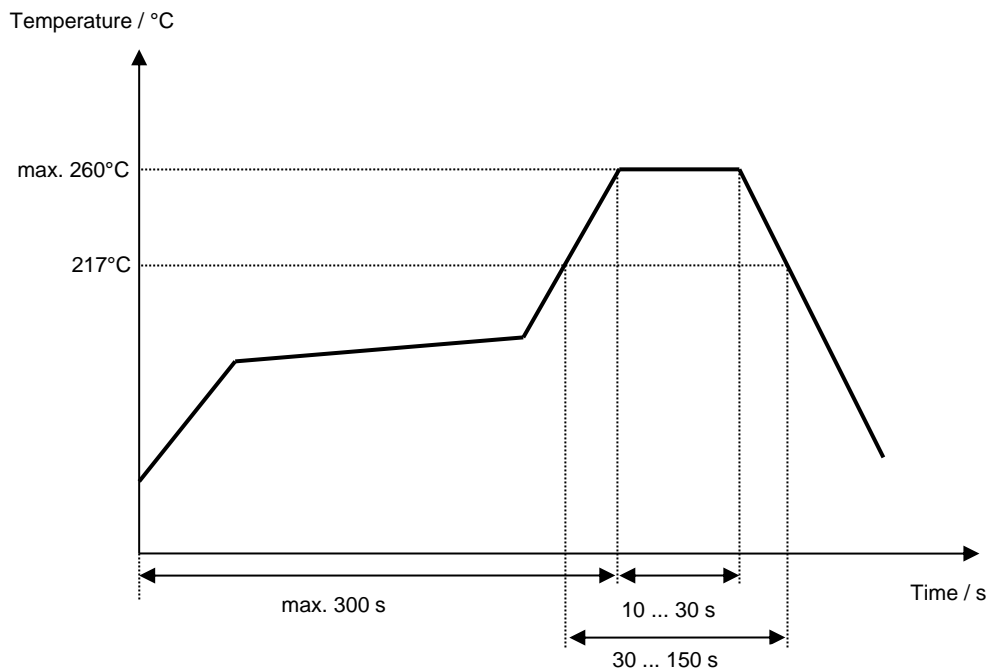

Microchip Frequency Technology GmbH
Potsdamer Straße 18
D 14 513 TELTOW / Germany
Tel: (+49) 3328 4784-0 / Fax: (+49) 3328 4784-30

Microchip Frequency Technology GmbH reserves the right to make changes to the product(s) and/or information contained herein without notice. No liability is assumed as a result of their use or application. No rights under any patent accompany the sale of any such product(s) or information.

Microchip**Filter specification****TFS1220C****5/5**

History

Version	Reason of Changes	Name	Date
1.0	- Generation of development specification according to customer specification	Steiner	02.04.2004
1.1	- Add typical values and filter characteristic - Generation of filter specification	Dr. Sabah	17.08.2005
2.0	- Typos corrected - Orientation of tape and reel updated	Molke	29.04.2016

Microchip Frequency Technology GmbH
Potsdamer Straße 18
D 14 513 TELTOW / Germany
Tel: (+49) 3328 4784-0 / Fax: (+49) 3328 4784-30

Microchip Frequency Technology GmbH reserves the right to make changes to the product(s) and/or information contained herein without notice. No liability is assumed as a result of their use or application. No rights under any patent accompany the sale of any such product(s) or information.