

**Microchip**

**Filter specification**

**TFS140BG**

**Measurement condition**

Ambient temperature $T_A$ :	23	°C
Input power level:	0	dBm
Terminating impedance: *		
Input:	109 $\Omega$	-11.1 pF
Output:	90 $\Omega$	-11.1 pF

**Characteristics**

**Remark:**

The reference level for the relative attenuation  $a_{rel}$  of the TFS 140BG is the minimum of the pass band attenuation. This value is defined as the insertion loss  $a_e$ . The centre frequency  $f_C$  is the arithmetic mean value of the upper and lower frequencies at the 3 dB filter attenuation level relative to the insertion loss  $a_e$ . The nominal frequency  $f_N$  is fixed at 140 MHz without any tolerance. The values of relative attenuation  $a_{rel}$  are guaranteed for the whole operating temperature range. The frequency shift of the filter in the operating temperature range is included in the production tolerance scheme.

<b>D a t a</b>	<b>typ. value</b>		<b>tolerance / limit</b>		
<b>Insertion loss</b> (reference level)	$a_e$	28	max.	30	dB
<b>Nominal frequency</b>	$f_N$			140	MHz
<b>Centre frequency ***</b>	$f_C$	140	MHz	$\pm$ 0.15	MHz
<b>Passband</b>	PB		$f_N$	$\pm$ 15	MHz
<b>Bandwidth</b>					
0.8 dB		33.2	min.	30	MHz
3 dB		33.9	min.	32	MHz
40 dB		36	max.	38	MHz
<b>Amplitude ripple in PB</b>		0.23	max.	0.8	dB
<b>Amplitude ripple in PB (any 2.5MHz)</b>		0.18	max.	0.3	dB
<b>Amplitude ripple in PB (any 5MHz)</b>		0.18	max.	0.4	dB
<b>Amplitude ripple in PB (any 10MHz)</b>		0.18	max.	0.5	dB
<b>Amplitude ripple in <math>f_N \pm 16</math>MHz ***</b>		0.23	max.	0.8	dB
<b>Relative attenuation</b>	$a_{rel}$				
$f_N$	... $f_N \pm$ 15	MHz	max.	0.8	dB
$f_N \pm$ 15	MHz ... $f_N \pm$ 16	MHz	max.	3	dB
$f_N \pm$ 19	MHz ... $f_N \pm$ 50	MHz	min.	40	dB
<b>Phase ripple in PB</b>		1.2	max.	2	°p-p
<b>Phase ripple in PB (any 2.5MHz)</b>		0.83	max.	1.5	°p-p
<b>Phase ripple in PB (any 5MHz)</b>		1.02	max.	1.75	°p-p
<b>Phase ripple in PB (any 10MHz)</b>		1.04	max.	1.75	°p-p
<b>Phase ripple in <math>f_N \pm 16</math>MHz ***</b>		1.2	max.	2	°p-p
<b>Group delay ripple in PB</b>		20	max.	70	ns
<b>Return loss in PB</b>		12	min.	9	dB
<b>IIP3 ****</b>		-	min.	30	dBm
<b>Operating temperature range</b>	OTR			- 40 °C ... + 85°C	
<b>Storage temperature range</b>				- 55 °C ... + 125°C	
<b>Temperature coefficient of frequency</b>	$TC_f$ **	-80	ppm/K		-

\*) The terminating impedances depend on parasitics and q-values of matching elements and the board used, and are to be understood as reference values only. Should there be additional questions do not hesitate to ask for an application note or contact our design team.

\*\*)  $\Delta f = TC_f(T - T_A)f_N$

\*\*\*) At room temperature only.

\*\*\*\*)  $f_{m1} = 139$ MHz;  $f_{m2} = 141$ MHz;  $P_m = 0$ dBm;  $f_{measurement1} = 137$ MHz;  $f_{measurement2} = 143$ MHz.

**Generated:**

**Checked / Approved:**

**Microchip Frequency Technology GmbH**  
**Potsdamer Straße 18**  
**D 14 513 TELTOW / Germany**  
**Tel: (+49) 3328 4784-0 / Fax: (+49) 3328 4784-30**

Microchip Frequency Technology GmbH reserves the right to make changes to the product(s) and/or information contained herein without notice. No liability is assumed as a result of their use or application. No rights under any patent accompany the sale of any such product(s) or information.

**Filter characteristic**

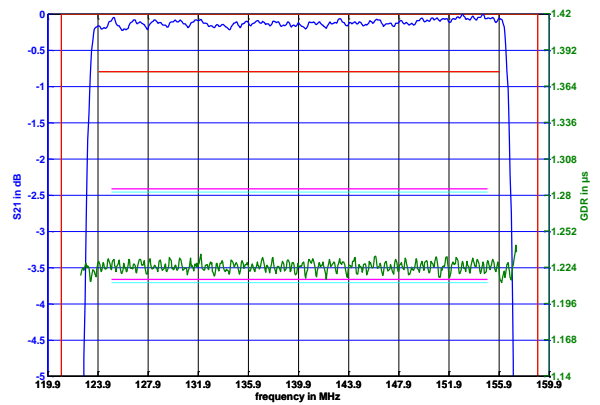
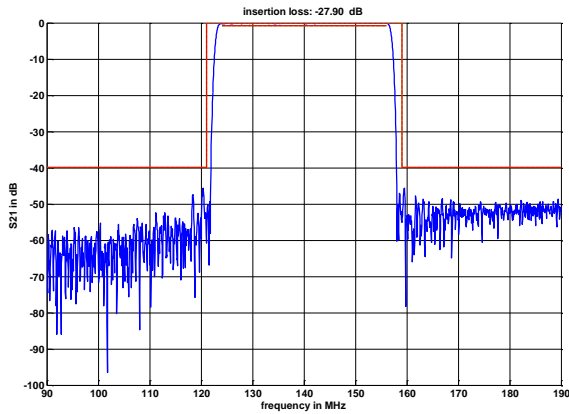

**Construction and pin connection**

(All dimensions in mm)

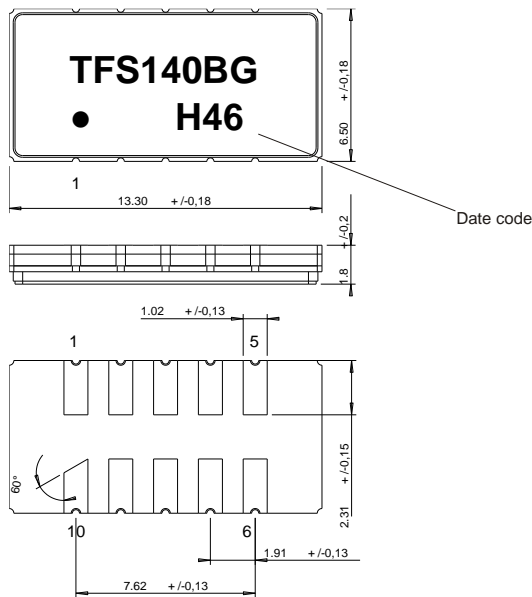

1	Ground
2	Ground
3	Ground
4	Ground
5	Output
6	Ground
7	Ground
8	Ground
9	Ground
10	Input

Date code: Year + week  
 H 2016  
 J 2017  
 K 2018  
 ...

**50 Ω Test circuit**

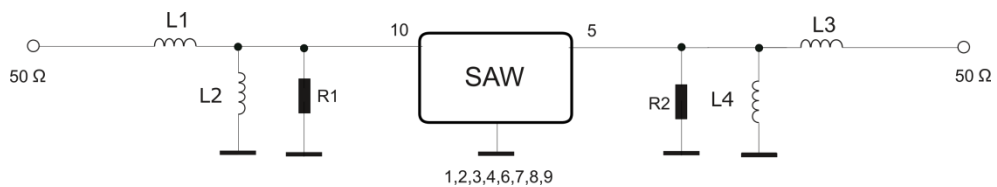

**Microchip Frequency Technology GmbH**  
 Potsdamer Straße 18  
 D 14 513 TELTOW / Germany  
 Tel: (+49) 3328 4784-0 / Fax: (+49) 3328 4784-30

Microchip Frequency Technology GmbH reserves the right to make changes to the product(s) and/or information contained herein without notice. No liability is assumed as a result of their use or application. No rights under any patent accompany the sale of any such product(s) or information.

**Stability characteristics, reliability**

After the following tests the filter shall meet the whole specification:

1. Shock: 500 g, 1 ms, half sine wave, 3 shocks each plane;  
DIN IEC 60068 T2 - 27
2. Vibration: 10 Hz to 2000 Hz, 0.35 mm or 5 g respectively, 1 octave per min, 10 cycles per plane, 3 planes; DIN IEC 60068 T2 - 6
3. Change of temperature: -55 °C to 125 °C / 15 min. each / 100 cycles  
DIN IEC 60068 part 2 – 14 Test N
4. Resistance to solder heat (reflow): reflow possible: three times max.;  
for temperature conditions refer to the attached "Air reflow temperature conditions" on page 4;
5. SAW devices are Electrostatic Discharge (ESD) sensitive devices.

This filter is RoHS compliant (2011/65/EU)

**Packing**

Tape & Reel: IEC 286 – 3, with exception of value for N and minimum bending radius;  
tape type II, embossed carrier tape with top cover tape on the upper side;

max. pieces of filters per reel:	1700
reel of empty components at start:	min. 300 mm
reel of empty components at start including leader:	min. 500 mm
trailer:	min. 300 mm

**Tape (all dimensions in mm)**

- W : 24.00 +0.30/-0.10
- Po : 4.00 ±0.1
- Do : 1.50 +0.1/0
- E : 1.75 ±0.10
- F : 11.50 ±0.10
- G(min) : 0.60
- P2 : 2.00 ±0.1
- P1 : 12.00 ±0.1
- D1(min) : 1.50
- Ao : 7.00 ±0.10
- Bo : 13.80 ±0.10
- Ct : 21.00 ±0.1
- Ko : 2.10 ±0.10
- t : 0.30 ±0.05

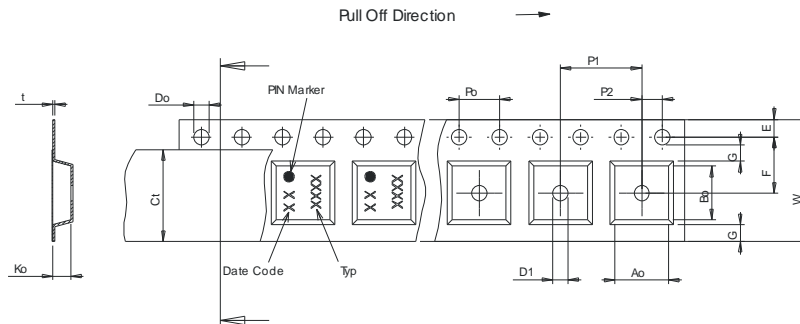

**Reel (all dimensions in mm)**

- A : 330 or 180
- W1 : 24.4 +2/-0
- W2(max) : 30.40
- N(min) : 60.00
- C : 13.0 +0.5/-0.2

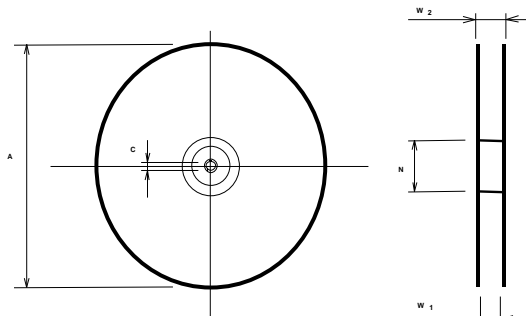

The minimum bending radius is 45 mm.

**Microchip Frequency Technology GmbH**  
**Potsdamer Straße 18**  
**D 14 513 TELTOW / Germany**  
**Tel: (+49) 3328 4784-0 / Fax: (+49) 3328 4784-30**

Microchip Frequency Technology GmbH reserves the right to make changes to the product(s) and/or information contained herein without notice. No liability is assumed as a result of their use or application. No rights under any patent accompany the sale of any such product(s) or information.

**Air reflow temperature conditions**

<b>Conditions</b>	<b>Exposure</b>
Average ramp-up rate (30 °C to 217 °C)	less than 3 °C / second
> 100 °C	between 300 and 600 seconds
> 150 °C	between 240 and 500 seconds
> 217 °C	between 30 and 150 seconds
Peak temperature	max. 260 °C
Time within 5 °C of actual peak temperature	between 10 and 30 seconds
Cool-down rate (Peak to 50 °C)	less than 6 °C / second
Time from 30 °C to Peak temperature	no greater than 300 seconds

**Chip-mount air reflow profile**



**Microchip****Filter specification****TFS140BG****5/5****History**

<b>Version</b>	<b>Reason of Changes</b>	<b>Name</b>	<b>Date</b>
1.0	Generation of development specification	TCUK	04.02.2014
1.1	Customer request to add centre frequency tolerance (at RT) & typ value for $TC_f$ .	TCUK	06.02.2014
1.2	Correct typo error on 40dB relative atten. level from $\pm 25,5$ to $\pm 19.0$ MHz	TCUK	11.08.2014
2.0	Customer agreed changes, loss to 30dB max and now use 13x6 10-pad pkg.	TCUK	26.01.2015
2.1	Change to Filter Spec. Add terminating impedance, typical values, & plots	TCUK	13.03.2015
2.2	Added IIP3 tone & test frequencies, & corrected typo in IIP3 units & vibration stability section.	TCUK	24.05.2015
2.3	Re-worked IIP3 statement.	TCUK	25.05.2015
3.0	Change tape & reel dimensions Update header and footer sections Update data section Update 50 $\Omega$ Test circuit scheme Update stability characteristics, reliability	Laifi	08.11.2016

---

**Microchip Frequency Technology GmbH**  
**Potsdamer Straße 18**  
**D 14 513 TELTOW / Germany**  
**Tel: (+49) 3328 4784-0 / Fax: (+49) 3328 4784-30**

---

Microchip Frequency Technology GmbH reserves the right to make changes to the product(s) and/or information contained herein without notice. No liability is assumed as a result of their use or application. No rights under any patent accompany the sale of any such product(s) or information.