

**1. Measurement condition :**

Ambient temperature  $T_A$ : 23 °C  
 Input power level: 0 dBm.  
 Terminating impedances at  $f_C$  \* ) :  
 for input: 214  $\Omega$  || - 13,02 pF.  
 for output: 189  $\Omega$  || - 13,61 pF.

**2. Characteristics :**

Remark: Reference level for the relative attenuation  $a_{rel}$  of the **TFS 140A3** is the minimum of the pass band attenuation  $a_{min}$ . The minimum of the pass band attenuation  $a_{min}$  is defined as the insertion loss  $a_e$ . The reference frequency  $f_C$  is the arithmetic mean value of the upper and lower frequencies at the 3 dB filter attenuation level relative to the insertion loss  $a_e$ . The temperature coefficient of frequency  $T_{Cf}$  is valid both for the reference frequency  $f_C$  and the frequency response of the filter in the operating temperature range. The frequency shift of the filter in the operating temperature range is not included in the production tolerance scheme

Data		typ. value	tolerance / limit
<b>Insertion loss</b> (Reference level)	$a_e$	23,5 dB	max. 25 dB
<b>Centre frequency</b> at ambient temperature $T_A$ ( $f_{CAT}$ )	$f_C$	140,01 MHz	140 $\pm$ 0,10 MHz
<b>Pass band</b> at ambient temperature $T_A$ :	<b>PB</b>	-	$f_C$ - 1,50 MHz..... $f_C$ + 1,50 MHz
<b>Amplitude ripple (p-p):</b>	$f_C$ ... $f_C \pm 1,35$ MHz	0,5 dB	-
	$f_C \pm 1,35$ MHz $f_C \pm 1,42$ MHz	0,7 dB	-
<b>Bandwidth</b> at ambient temperature:			
1 dB		2,88 MHz	min. 2,4 MHz
3 dB		3,15 MHz	min. 3,0 MHz
20 dB		3,83 MHz	-
40 dB		4,20 MHz	max. 4,4 MHz
45 dB		4,24 MHz	max. 5,0 MHz
<b>Relative attenuation</b> $a_{rel}$			
$f_C$ .....	$f_C \pm 1,2$ MHz	-	max. 1 dB
$f_C \pm 1,2$ MHz .....	$f_C \pm 1,5$ MHz	-	max. 3 dB
$f_C \pm 2,2$ MHz .....	$f_C \pm 2,5$ MHz	45...55 dB	min. 40 dB
$f_C \pm 2,5$ MHz .....	$f_C \pm 39$ MHz	60...70 dB	min. 45 dB
$f_C \pm 39$ MHz .....	$f_C \pm 41$ MHz	65...70 dB	min. 60 dB
<b>Group delay ( mean value in pass band ):</b>			
		2,49 $\mu$ s	max. 2,5 $\mu$ s
<b>Group delay ripple in pass band (p-p):</b>			
		65 ns	max. 100 ns
<b>Deviation from linear phase in pass band (p-p):</b>			
		$\pm 1,8^\circ$ (r.m.s. 1,4 $^\circ$ )	$\pm$ max. 5 degree
<b>S11 in PB :</b>			
		8 dB	-
<b>S22 in PB :</b>			
		8 dB	-
<b>Triple transit attenuation compared to main signal</b>			
		52 dB	min. 40 dB
<b>Crosstalk</b>			
		55 dB	-
<b>Frequency inversion temperature ( <math>T_o</math> )</b>			
		25 °C	-
<b>Temperature coefficient of frequency ( <math>T_{Cf}</math> )</b>			
		-0,045 ppm/K <sup>2</sup>	-
<b>Frequency deviation of <math>f_C</math> over temperature: ** )</b>			
		$\Delta f_C(\text{Hz}) = T_{Cf}(\text{ppm/K}) \times (T - T_o)^2 \times f_{T_o}(\text{MHz})$	-
<b>Operating temperature range</b>			
		-	- 40 °C ... + 85 °C
<b>Storage temperature range</b>			
		-	- 40 °C ... + 85 °C

\*) The terminating impedances and insertion loss depend on parasitics and q-values of matching elements and the board used, and are to be understood as reference values only. Should there be additional questions do not hesitate to ask for an application note or contact our design team.

\*\* )  $f_{T_o}$  is reference frequency  $f_C$  at frequency inversion temperature ( $T_o$ )

**Generated:** Dunzow W.

**Checked / approved:** Dr. Bert Wall

**Microchip Frequency Technology GmbH**  
**Potsdamer Straße 18**  
**D 14 513 TELTOW / Germany**  
**Tel: (+49) 3328 4784-0 / Fax: (+49) 3328 4784-30**

Microchip Frequency Technology GmbH reserves the right to make changes to the product(s) and/or information contained herein without notice. No liability is assumed as a result of their use or application. No rights under any patent accompany the sale of any such product(s) or information.

### 3. Package and pin connection : (All dimensions in mm)

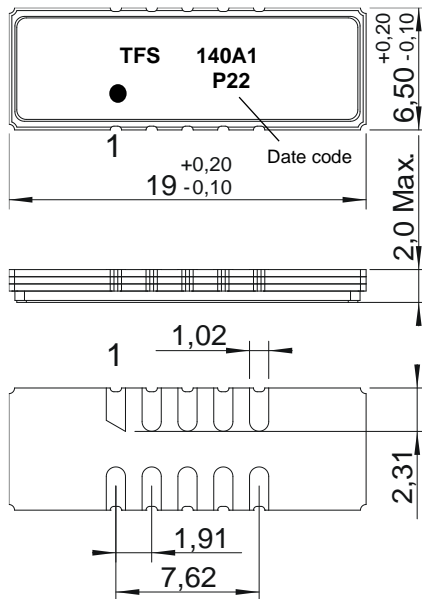

Date code: Year+week  
 M 2001  
 N 2001  
 P 2002

Pin 10 **Input**  
 Pin 1 Input RF Return  
 Pin 5 **Output**  
 Pin 6 Output RF Return  
 Pin 2 - 4, 7 - 9 Package Ground

### 4. 50 $\Omega$ matching network ( for details refer to application note) :

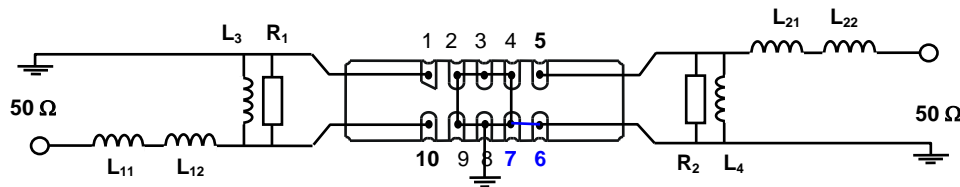

Scheme 1.

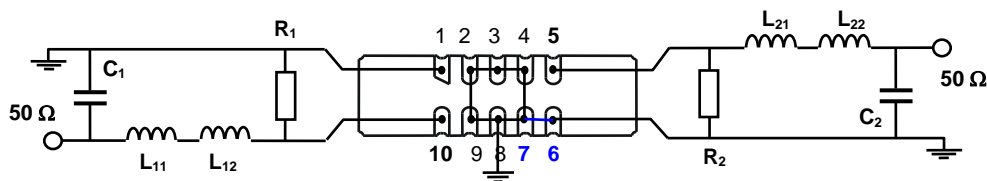

Scheme 2.

For final test we use scheme 1.

Microchip Frequency Technology GmbH  
 Potsdamer Straße 18  
 D 14 513 TELTOW / Germany  
 Tel: (+49) 3328 4784-0 / Fax: (+49) 3328 4784-30

Microchip Frequency Technology GmbH reserves the right to make changes to the product(s) and/or information contained herein without notice. No liability is assumed as a result of their use or application. No rights under any patent accompany the sale of any such product(s) or information.

**5. Stability characteristics :**

After the following tests the filter shall meet the whole specification:

1. Shock: 500g, 18 ms, half sine wave, 3 shocks each plane;  
DIN IEC 68 T2 - 27
2. Vibration: 10 Hz to 500 Hz, 0,35 mm or 5g respectively, 1 octave per min, 10 cycles per plan, 3 plans;  
DIN IEC 68 T2 - 6
3. Change of temperature: -55 °C to 125°C / 30 min. each / 10 cycles  
DIN IEC 68 part 2 – 14 Test N
4. Resistance to solder heat (reflow): reflow possible: twice max.;  
for temperature conditions refer to the attached "Air reflow temperature conditions" on page 4;

**6. Packing :**

Tape & Reel: DIN IEC 286 - 3, with exception of value for N and minimum bending radius;  
tape type II, embossed carrier tape with top cover tape on the upper side;

max. pieces of filters per reel: 2000  
reel of empty components at start: min 300 mm  
reel of empty components at start including leader: min 500 mm  
Trailer: min 300 mm

**Tape (all dimensions in mm)**

W	:	32	± 0,3
Po	:	4	± 0,1
Do	:	1,5	+ 0,1
E	:	1,75	± 0,1
So	:	28,4	± 0,1
F	:	14,2	± 0,1
G (min)	:	0,6	
P2	:	2	± 0,1
P1	:	12	± 0,1
D1(min)	:	2,0	
Ao	:	7,1	± 0,1
Bo	:	19,6	± 0,1
Ko	:	2,0	± 0,1
t	:	0,35	± 0,35
Ct	:	25,5	± 0,1

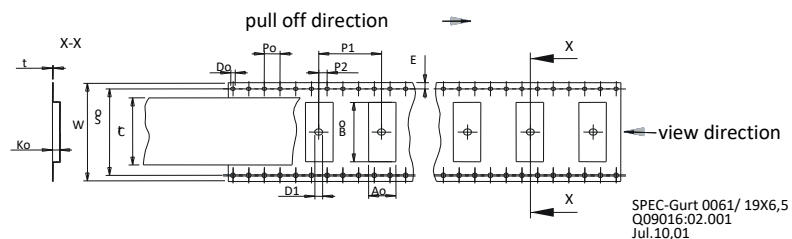
**Reel (all dimensions in mm):**

A	:	330
W1	:	32,4 + 2
W2(max)	:	38,4
N(min)	:	100
C	:	13 ± 0,5 / - 0,2

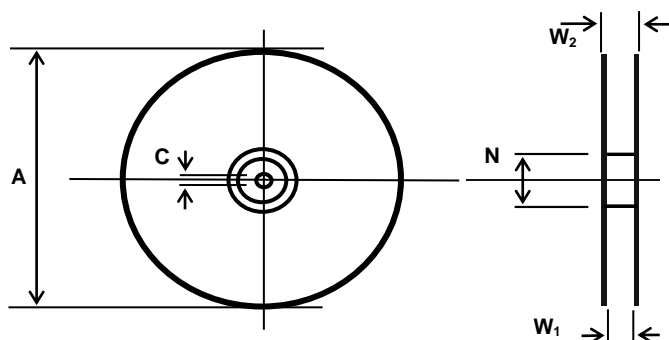

The minimum bending radius is 45 mm. The mounting surface of the filters faces the bottom side of the embossed carrier tape. The marking of the filters is able to read if the view is directed on the upper side of the carrier tape in the above shown direction.

**Microchip Frequency Technology GmbH**  
**Potsdamer Straße 18**  
**D 14 513 TELTOW / Germany**  
**Tel: (+49) 3328 4784-0 / Fax: (+49) 3328 4784-30**

Microchip Frequency Technology GmbH reserves the right to make changes to the product(s) and/or information contained herein without notice. No liability is assumed as a result of their use or application. No rights under any patent accompany the sale of any such product(s) or information.

**7. Air reflow temperature conditions :**

1st and 2nd air reflow profile

<b>Name:</b>	pre-heating periods	main-heating periods	peak temperature
<b>Temperature:</b>	150 °C - 170 °C	over 200 °C	255 °C ± 5 °C
<b>Time:</b>	60 sec. - 90 sec.	20 sec. - 25 sec.	

**Chip-mount air reflow profile**

Table for temperature vs. time during the air reflow process

Tolerance of temperatures: ± 5 °C

time / sec.	temperature / °C	time / sec.	temperature / °C
0	23	140	160
10	34	150	161
20	46	160	164
30	60	170	170
40	80	180	180
50	103	190	205
60	121	195	230
70	134	200	255
80	143	205	230
90	150	210	205
100	154	215	180
110	156	220	165
120	158	230	140
130	159	240	120

**Microchip Frequency Technology GmbH**  
**Potsdamer Straße 18**  
**D 14 513 TELTOW / Germany**  
**Tel: (+49) 3328 4784-0 / Fax: (+49) 3328 4784-30**

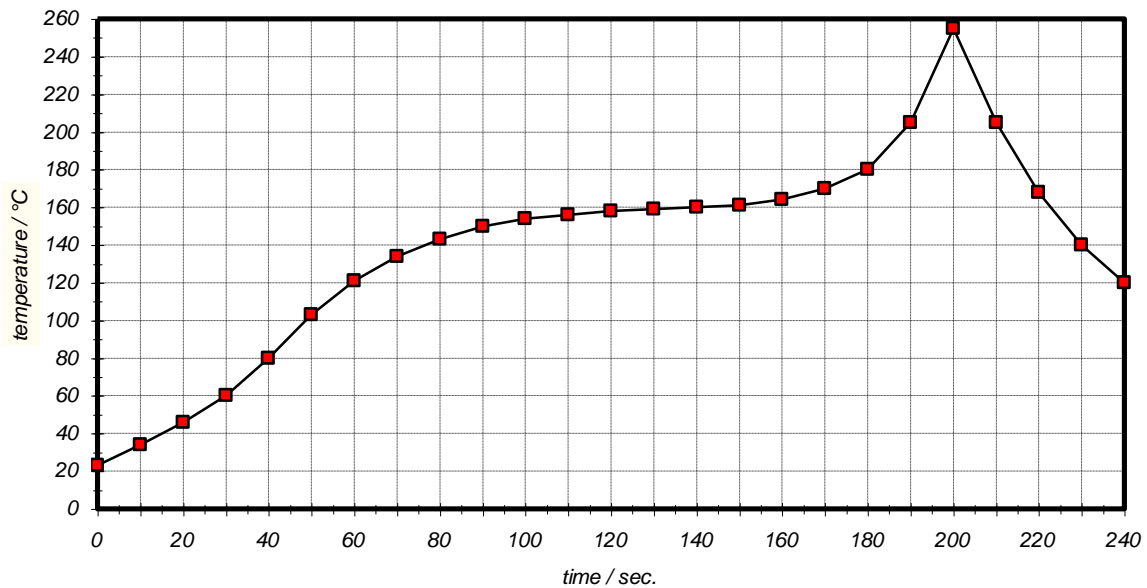
Microchip Frequency Technology GmbH reserves the right to make changes to the product(s) and/or information contained herein without notice. No liability is assumed as a result of their use or application. No rights under any patent accompany the sale of any such product(s) or information.

**8. History :**

<b>Version</b>	<b>Reason of changes</b>	<b>Name</b>	<b>Date</b>
1.0	Generate filter specification according to customer requirements.	Dunzow W.	15.01.2002
1.1	change marking from TFS 140A3 to TFS 140A1.	Dunzow W.	19.11.2002