

Microchip

Filter specification

TFS 150AR

Measurement condition

Ambient temperature:	23	°C
Input power level:	0	dBm
Terminating impedance: *		
Input:	73.43 Ω	- 16.87 pF
Output:	111.51 Ω	- 11.96 pF

Characteristics

Remark:

The reference level for the relative attenuation a_{rel} of the TFS 150AR is the minimum of the pass band attenuation a_{min} . The minimum of the pass band attenuation a_{min} is defined as the insertion loss a_e . The centre frequency f_c is the arithmetic mean value of the upper and lower frequencies at the 3 dB filter attenuation level relative to the insertion loss a_e . The temperature coefficient of frequency TC_f is valid for both the reference frequency f_c and the frequency response of the filter in the operating temperature range. The frequency shift of the filter in the operating temperature range is not included in the production tolerance scheme.

Data		typ. value	tolerance / limit
Insertion loss (reference level)	a_e	21,6 dB	max. 24,0 dB
Nominal frequency	f_N	-	150,0 MHz
Centre frequency at ambient temperature	f_c	150,0 MHz	± 0,1 MHz
Passband	PB		f_c ± 12,06 MHz
Pass band ripple	p-p	0,7 dB	max. 1,0 dB
Bandwidth	BW		
3 dB		24,96 MHz	min. 24,9 MHz
17 dB		25,73 MHz	max. 26,0 MHz
30 dB		26,25 MHz	max. 27,2 MHz
Relative attenuation	a_{rel}		
f_c ... f_c ± 12,06 MHz		0,7 dB	max. 1 dB
f_c ± 13,0 MHz ... f_c ± 13,6 MHz		25 dB	min. 17 dB
f_c ± 13,6 MHz ... f_c ± 17,0 MHz		36 dB	min. 30 dB
f_c ± 17,0 MHz ... f_c ± 50,0 MHz		50 dB	min. 45 dB
Group delay	mean value in PB	1,62 μs	max. 1,7 μs
Group delay ripple within PB		104 ns	max. 125 ns
Return loss within PB		12,1 dB	min. 8 dB
Operating temperature range	OTR	-	- 30 °C ... + 85 °C
Storage temperature range		-	- 40 °C ... + 85 °C
Temperature coefficient of frequency	TC_f **	-74 ppm/K	-

*) The terminating impedances depend on parasites and q-values of matching elements and the board used, and are to be understood as reference values only. Should there be additional questions do not hesitate to ask for an application note or contact our design team.

**) $\Delta f(\text{Hz}) = TC_f(\text{ppm/K}) \times (T - T_0) \times f_{T0}(\text{MHz})$

Generated:

Checked / Approved:

Microchip Frequency Technology GmbH
Potsdamer Straße 18
D 14 513 TELTOW / Germany
Tel: (+49) 3328 4784-0 / Fax: (+49) 3328 4784-30

Microchip Frequency Technology GmbH reserves the right to make changes to the product(s) and/or information contained herein without notice. No liability is assumed as a result of their use or application. No rights under any patent accompany the sale of any such product(s) or information.

Filter characteristic

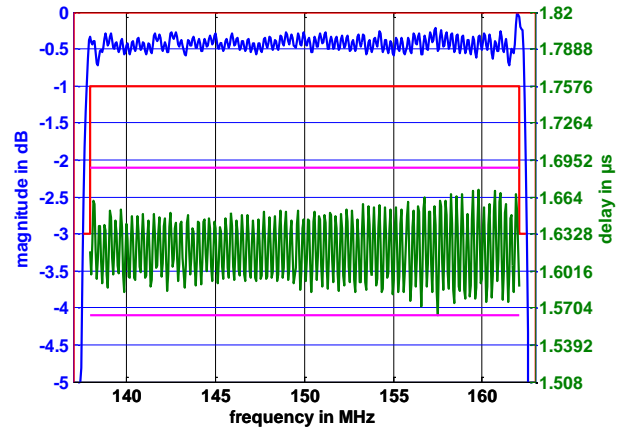
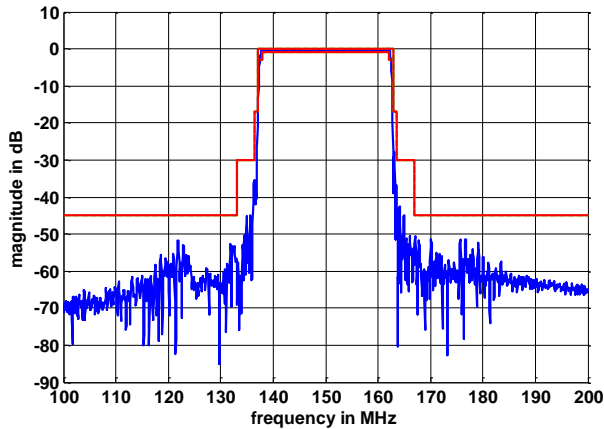

Construction and pin connection

(All dimensions in mm)

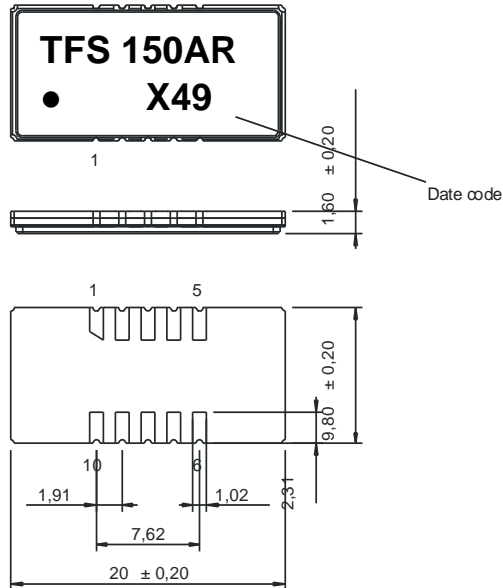

- 1 Ground
- 2 Ground
- 3 Ground
- 4 Output RF Return
- 5 Output
- 6 Ground
- 7 Ground
- 8 Ground
- 9 Input RF Return
- 10 Input

Date code: Year + week
 X 2009
 A 2010
 B 2011
 ...

50 Ohm Test circuit

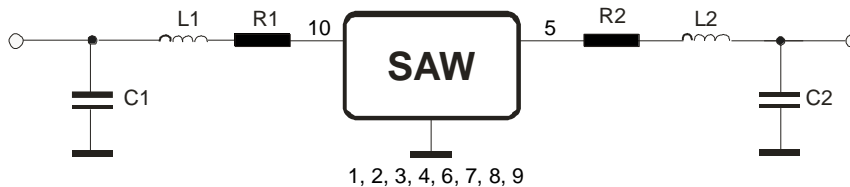

Microchip Frequency Technology GmbH
 Potsdamer Straße 18
 D 14 513 TELTOW / Germany
 Tel: (+49) 3328 4784-0 / Fax: (+49) 3328 4784-30

Microchip Frequency Technology GmbH reserves the right to make changes to the product(s) and/or information contained herein without notice. No liability is assumed as a result of their use or application. No rights under any patent accompany the sale of any such product(s) or information.

Stability characteristics, reliability

After the following tests the filter shall meet the whole specification:

1. Shock: 500g, 1 ms, half sine wave, 3 shocks each plane;
DIN IEC 68 T2 - 27
2. Vibration: 10 Hz to 500 Hz, 0,35 mm or 5 g respectively, 1 octave per min, 10 cycles per plane, 3 planes;
DIN IEC 68 T2 - 6
3. Change of temperature: -55 °C to 125°C / 30 min. each / 10 cycles
DIN IEC 68 part 2 – 14 Test N
4. Resistance to solder heat (reflow): reflow possible: three times max.;
for temperature conditions refer to the attached "Air reflow temperature conditions" on page 4;

This filter is RoHS compliant (2002/95/EG, 2005/618/EG)

Packing

Tape & Reel: IEC 286 – 3, with exception of value for N and minimum bending radius;
tape type II, embossed carrier tape with top cover tape on the upper side;

max. pieces of filters per reel:
reel of empty components at start: min. 300 mm
reel of empty components at start including leader: min. 500 mm
trailer: min. 300 mm

Tape (all dimensions in mm)

- W : 32,00
- Po : 4,00 ± 0,1
- Do : 1,50 +0,1/-0
- E : 1,75 ± 0,1
- F : 14,20 ± 0,1
- G(min) :
- P2 : 2,00 ± 0,1
- P1 : 16,00 ± 0,1
- D1(min) : 2,00
- Ao : 10,25 ± 0,1
- Bo : 20,45
- Ct : 25,5

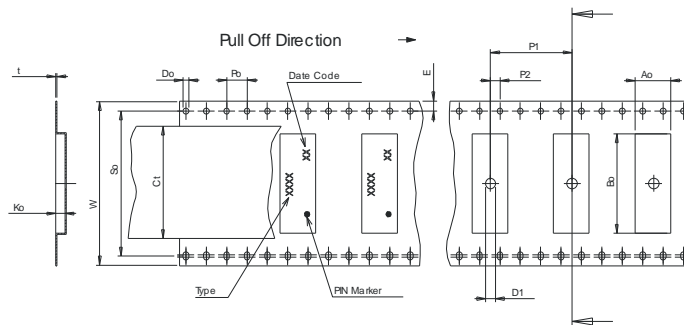

Reel (all dimensions in mm)

- A : 330
- W1 : 32,4
- W2(max) : 38,4
- N(min) : 100
- C : 13,0

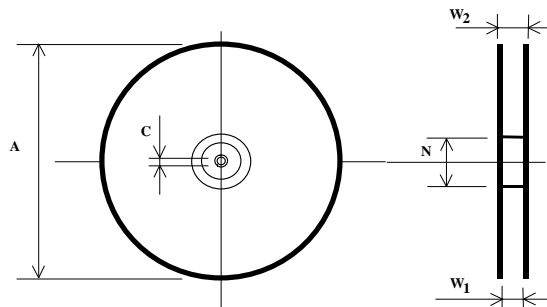

The minimum bending radius is 45 mm.

Microchip Frequency Technology GmbH
Potsdamer Straße 18
D 14 513 TELTOW / Germany
Tel: (+49) 3328 4784-0 / Fax: (+49) 3328 4784-30

Microchip Frequency Technology GmbH reserves the right to make changes to the product(s) and/or information contained herein without notice. No liability is assumed as a result of their use or application. No rights under any patent accompany the sale of any such product(s) or information.

Air reflow temperature conditions

Conditions	Exposure
Average ramp-up rate (30°C to 217°C)	less than 3°C/second
> 100°C	between 300 and 600 seconds
> 150°C	between 240 and 500 seconds
> 217°C	between 30 and 150 seconds
Peak temperature	max. 260°C
Time within 5°C of actual peak temperature	between 10 and 30 seconds
Cool-down rate (Peak to 50°C)	less than 6°C/second
Time from 30°C to Peak temperature	no greater than 300 seconds

Chip-mount air reflow profile

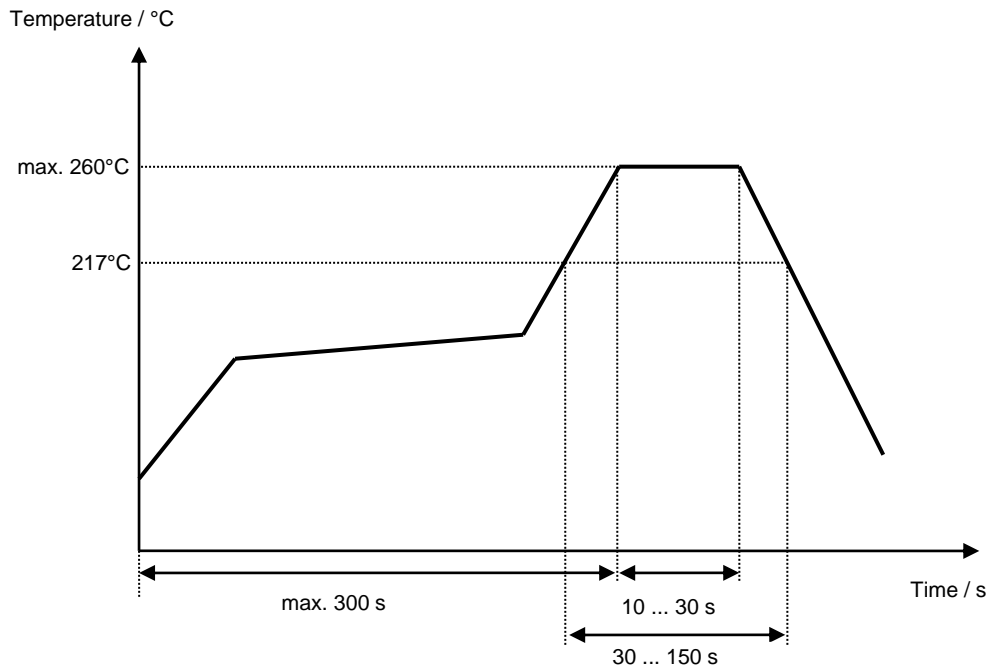

Microchip Frequency Technology GmbH
Potsdamer Straße 18
D 14 513 TELTOW / Germany
Tel: (+49) 3328 4784-0 / Fax: (+49) 3328 4784-30

Microchip Frequency Technology GmbH reserves the right to make changes to the product(s) and/or information contained herein without notice. No liability is assumed as a result of their use or application. No rights under any patent accompany the sale of any such product(s) or information.

Microchip**Filter specification****TFS 150AR****5/5**

History

Version	Reason of Changes	Name	Date
1.0	- Generation of development specification	TCUK	15.12.2010
1.1	- Update with customer agreed changes, use the same package schematic as the TFS150AL	Jaffer	17.03.2011
2.0	- Change 3dB bw to 24.9MHz min (was 25MHz min) & update (with N22) typical values	Jaffer	09.05.2011
2.1	- Update from development to filter specification	TCUK	19.10.2011
2.2	- Correct typo error on tape & reel information.	TCUK	08.10.2012

Microchip Frequency Technology GmbH
Potsdamer Straße 18
D 14 513 TELTOW / Germany
Tel: (+49) 3328 4784-0 / Fax: (+49) 3328 4784-30

Microchip Frequency Technology GmbH reserves the right to make changes to the product(s) and/or information contained herein without notice. No liability is assumed as a result of their use or application. No rights under any patent accompany the sale of any such product(s) or information.