

|                  |                             |                |            |
|------------------|-----------------------------|----------------|------------|
| <b>Microchip</b> | <b>Filter specification</b> | <b>TFS1610</b> | <b>1/5</b> |
|------------------|-----------------------------|----------------|------------|

**Measurement condition**

|                             |    |          |
|-----------------------------|----|----------|
| Ambient temperature $T_A$ : | 23 | °C       |
| Input power level:          | 0  | dBm      |
| Terminating impedance:      |    |          |
| Input:                      | 50 | $\Omega$ |
| Output:                     | 50 | $\Omega$ |

**Characteristics**

Remark:

The maximum attenuation in the passband is defined as the insertion loss  $a_e$ . The nominal frequency  $f_N$  is fixed at 1610.125 MHz without any tolerance or limit. The values of absolute attenuation  $a_{abs}$  are guaranteed over the whole operating temperature range. The frequency shift of the filter within the operating temperature range is included in the production tolerance scheme.

| D a t a                                     |            | typ. value | tolerance / limit |                    |     |
|---|------------|------------|-------------------|--------------------|-----|
| <b>Insertion loss</b>                       | $a_e$      | 2.0 dB     | max.              | 3.5                | dB  |
| <b>Nominal frequency</b>                    | $f_N$      | -          |                   | 1610.125           | MHz |
| <b>Passband</b>                             | PB         | -          |                   | $f_N \pm 0.390$    | MHz |
| <b>Passband variation</b>                   | PBV        | 0.1 dB     | max.              | 1.0                | dB  |
| <b>Absolute attenuation</b>                 | $a_{abs}$  |            |                   |                    |     |
| 100 MHz ... 1565 MHz                        |            | 40 dB      | min.              | 30                 | dB  |
| 1645 MHz ... 1650 MHz                       |            | 45 dB      | min.              | 20                 | dB  |
| 1650 MHz ... 1680 MHz                       |            | 46 dB      | min.              | 30                 | dB  |
| 1680 MHz ... 1850 MHz                       |            | 43 dB      | min.              | 40                 | dB  |
| 1850 MHz ... 2000 MHz                       |            | 41 dB      | min.              | 38                 | dB  |
| <b>Return loss within PB</b>                |            | 16 dB      | min.              | 10                 | dB  |
| <b>IIP3</b>                                 | *)         | 35 dBm     | min.              | 30                 | dBm |
| <b>Input power level</b>                    |            | -          | max.              | 10                 | dBm |
| <b>Operating temperature range</b>          | OTR        | -          |                   | -40 °C ... +85 °C  |     |
| <b>Storage temperature range</b>            |            | -          |                   | -55 °C ... +125 °C |     |
| <b>Temperature coefficient of frequency</b> | $TC_f$ **) | -42 ppm/K  |                   |                    |     |

\*)  $f_{m1} = 1609.9750$  MHz,  $f_{m2} = 1609.9875$  MHz,  $P_{in} = 0$  dBm,  $f_{measurement} = 1610.0000$  MHz

\*\*)  $\Delta f = TC_f(T - T_A)f_N$

**Generated:** \_\_\_\_\_

**Checked / Approved:** \_\_\_\_\_

**Microchip Frequency Technology GmbH**  
**Potsdamer Straße 18**  
**D 14 513 TELTOW / Germany**  
**Tel: (+49) 3328 4784-0 / Fax: (+49) 3328 4784-30**

Microchip Frequency Technology GmbH reserves the right to make changes to the product(s) and/or information contained herein without notice. No liability is assumed as a result of their use or application. No rights under any patent accompany the sale of any such product(s) or information.

**Filter characteristic**

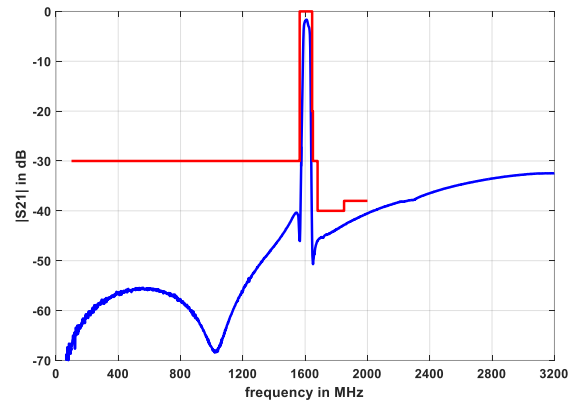
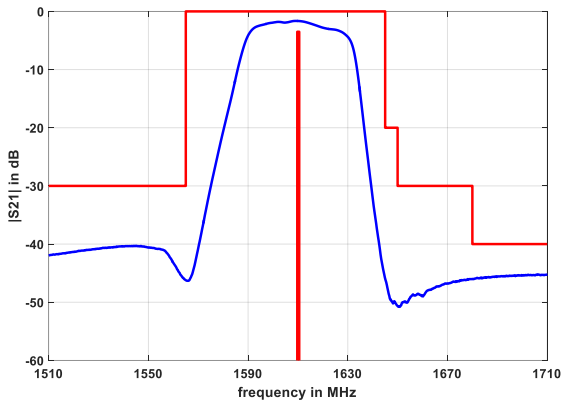

**Construction and pin connection**

(All dimensions in mm)

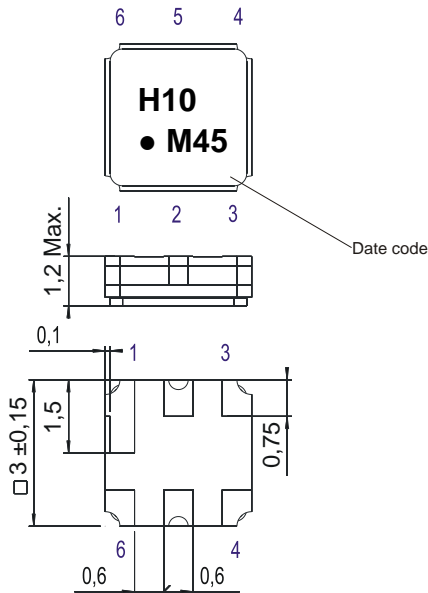

- 1 Ground
- 2 Input
- 3 Ground
- 4 Ground
- 5 Output
- 6 Ground

Date code: Year + week  
 M 2020  
 N 2021  
 P 2022  
 ...

**50 Ohm Test circuit**

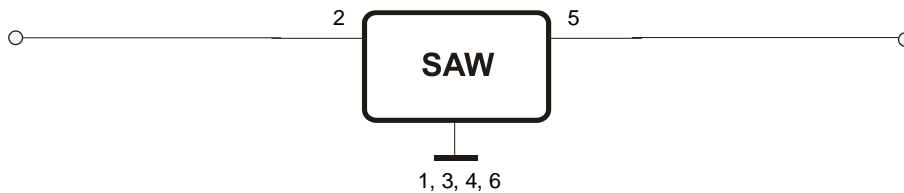

**Microchip Frequency Technology GmbH**  
 Potsdamer Straße 18  
 D 14 513 TELTOW / Germany  
 Tel: (+49) 3328 4784-0 / Fax: (+49) 3328 4784-30

Microchip Frequency Technology GmbH reserves the right to make changes to the product(s) and/or information contained herein without notice. No liability is assumed as a result of their use or application. No rights under any patent accompany the sale of any such product(s) or information.

**Stability characteristics, reliability**

After the following tests the filter shall meet the whole specification:

1. Shock: 500 g, 1 ms, half sine wave, 3 shocks each plane;  
DIN IEC 60068 T2 - 27
2. Vibration: 10 Hz to 2000 Hz, 0.35 mm or 5 g respectively, 1 octave per min, 10 cycles per plane, 3 planes; DIN IEC 60068 T2 - 6
3. Change of temperature: -55 °C to 125 °C / 15 min. each / 100 cycles  
DIN IEC 60068 part 2 – 14 Test N
4. Resistance to solder heat (reflow): reflow possible: three times max.;  
for temperature conditions refer to the attached "Air reflow temperature conditions" on page 4;
5. SAW devices are Electrostatic Discharge (ESD) sensitive devices.

This filter is RoHS compliant (2011/65/EU+2015/863/EU)

**Packing**

Tape & Reel: IEC 286 – 3, with exception of value for N and minimum bending radius;  
tape type II, embossed carrier tape with top cover tape on the upper side;

|   |             |
|---|-------------|
| reel of empty components at start:                  | min. 300 mm |
| reel of empty components at start including leader: | min. 500 mm |
| trailer:  | min. 300 mm |

**Tape (all dimensions in mm)**

- W : 8.00 ±0.3
- Po : 4.00 ±0.1
- Do : 1.50 +0.1/-0
- E : 1.75 ±0.1
- F : 3.50 ±0.05
- G(min) : 0.75
- P2 : 2.00 ±0.05
- P1 : 4.00 ±0.1
- D1(min) : 1.50
- Ao : 3.25 ±0.1
- Bo : 3.25 ±0.1
- Ct : 5.30 ±0.1
- Ko : 1.50 ±0.1
- t : 0.25 ±0.05

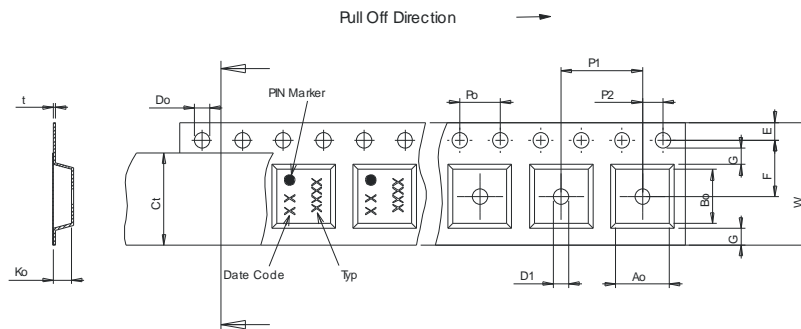

**Reel (all dimensions in mm)**

- A : 330 or 180
- W1 : 8.40 +1.5/-0
- W2(max) : 14.40
- N(min) : 60.00
- C : 13.0 ±0.2

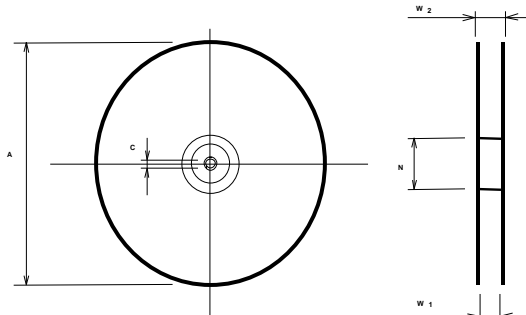

The minimum bending radius is 45 mm.

**Microchip Frequency Technology GmbH**  
**Potsdamer Straße 18**  
**D 14 513 TELTOW / Germany**  
**Tel: (+49) 3328 4784-0 / Fax: (+49) 3328 4784-30**

Microchip Frequency Technology GmbH reserves the right to make changes to the product(s) and/or information contained herein without notice. No liability is assumed as a result of their use or application. No rights under any patent accompany the sale of any such product(s) or information.

**Air reflow temperature conditions**

| <b>Conditions</b>                           | <b>Exposure</b>             |
|---|-----------------------------|
| Average ramp-up rate (30 °C to 217 °C)      | less than 3 °C / second     |
| > 100 °C                                    | between 300 and 600 seconds |
| > 150 °C                                    | between 240 and 500 seconds |
| > 217 °C                                    | between 30 and 150 seconds  |
| Peak temperature                            | max. 260 °C                 |
| Time within 5 °C of actual peak temperature | between 10 and 30 seconds   |
| Cool-down rate (Peak to 50 °C)              | less than 6 °C / second     |
| Time from 30 °C to Peak temperature         | no greater than 300 seconds |

**Chip-mount air reflow profile**

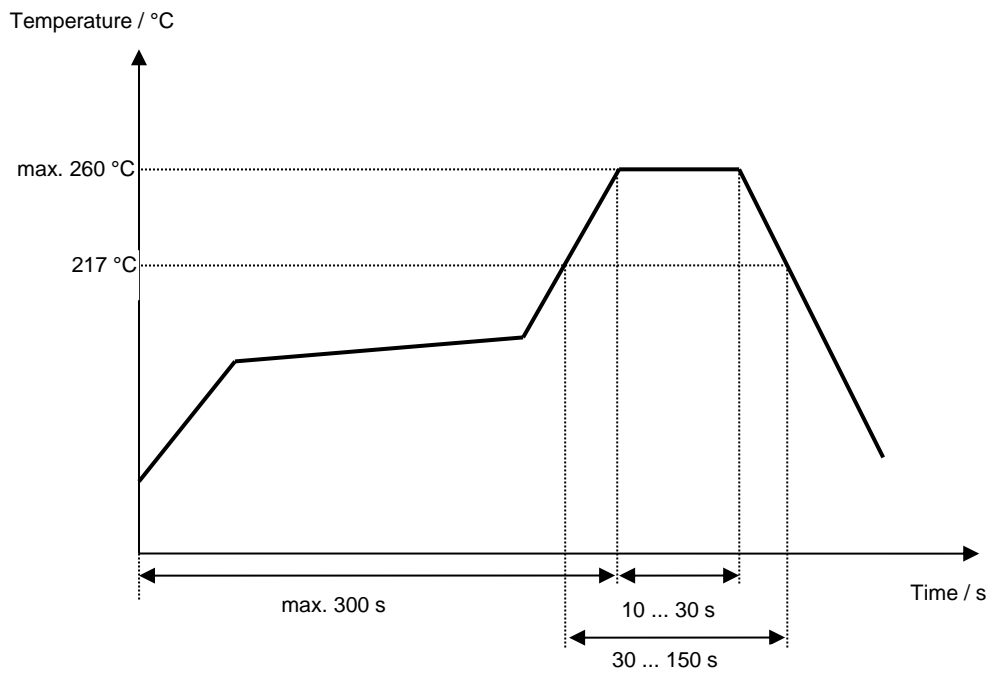

**Microchip Frequency Technology GmbH**  
**Potsdamer Straße 18**  
**D 14 513 TELTOW / Germany**  
**Tel: (+49) 3328 4784-0 / Fax: (+49) 3328 4784-30**

Microchip Frequency Technology GmbH reserves the right to make changes to the product(s) and/or information contained herein without notice. No liability is assumed as a result of their use or application. No rights under any patent accompany the sale of any such product(s) or information.

**Microchip****Filter specification****TFS1610****5/5****History**

| <b>Version</b> | <b>Reason of Changes</b>  | <b>Name</b> | <b>Date</b> |
|----------------|---|-------------|-------------|
| 1.0            | - Generation of development specification   | A. Molke    | 16.12.2019  |
| 2.0            | - Updated data table due to 1610_RFQ1_5c  | P. Jaster   | 10.03.2020  |
| 3.0            | - Updated passband variation segments<br>- Added IIP3 measurement conditions  | P. Jaster   | 05.05.2020  |
| 4.0            | - Update of data table (absolute attenuation)<br>- Change from development spec to filter spec<br>- Typical values added<br>- Filter characteristic added | A. Molke    | 03.11.2020  |

---

**Microchip Frequency Technology GmbH**  
**Potsdamer Straße 18**  
**D 14 513 TELTOW / Germany**  
**Tel: (+49) 3328 4784-0 / Fax: (+49) 3328 4784-30**

---

Microchip Frequency Technology GmbH reserves the right to make changes to the product(s) and/or information contained herein without notice. No liability is assumed as a result of their use or application. No rights under any patent accompany the sale of any such product(s) or information.