

Microchip**Filter specification****TFS 104****1/5****Measurement condition**

Ambient temperature:	23	°C
Input power level:	0	dBm
Terminating impedance: *		
Input:	2800 Ω	-2,5 pF
Output:	2800 Ω	-2,5 pF
External Coil:	560 nH	

Characteristics

Remark:

The reference level for the relative attenuation a_{rel} of the TFS 104 is the minimum of the pass band attenuation. This value is defined as the insertion loss a_e . The nominal frequency f_N is fixed at 104.0 MHz without any tolerance. The values of relative attenuation a_{rel} are guaranteed for the whole operating temperature range. The frequency shift of the filter in the operating temperature range is included in the production tolerance scheme.

Data	typ. value		tolerance / limit	
Insertion loss (reference level)	a_e	4,8 dB	max.	6 dB
Nominal frequency	f_N	-		104,0 MHz
Passband	PB	-	f_N ±	49 kHz
Pass band ripple		0,8 dB	max.	1,5 dB
Relative attenuation	a_{rel}			
f_N	... f_N ± 66 kHz	1,2 dB	max.	3 dB
f_N ± 150 kHz	... f_N ± 180 kHz	21 dB	min.	18 dB
f_N ± 180 kHz	... f_N ± 240 kHz	28 dB	min.	25 dB
f_N + 240 kHz	... f_N + 600 kHz	43 dB	min.	40 dB
f_N + 600 kHz	... f_N + 1,2 MHz	40 dB	min.	37 dB
f_N + 1,2 MHz	... f_N + 50 MHz	43 dB	min.	40 dB
f_N - 240 kHz	... f_N - 11 MHz	45 dB	min.	40 dB
f_N - 11,0 MHz	... f_N - 16 MHz	38 dB	min.	36 dB
f_N - 16 MHz	... f_N - 50 MHz	45 dB	min.	40 dB
Group delay ripple				
f_N ± 49 kHz		2 μs	max.	3,0 μs
Input power level		-	max.	13 dBm
Operating temperature range	OTR	-	- 25 °C ... + 85 °C	
Storage temperature range		-	- 33 °C ... + 85 °C	
Frequency inversion temperature		25 °C	-	
Temperature coefficient of frequency	TC_f **	-0,036 ppm/K ²	-	

*) The terminating impedances depend on parasitics and q-values of matching elements and the board used, and are to be understood as reference values only. Should there be additional questions do not hesitate to ask for an application note or contact our design team.

**) $\Delta f(\text{Hz}) = TC_f(\text{ppm/K}^2) \times (T - T_0)^2 \times f_{T0}(\text{MHz})$.

Generated:**Checked / Approved:**

Microchip Frequency Technology GmbH
Potsdamer Straße 18
D 14 513 TELTOW / Germany
Tel: (+49) 3328 4784-0 / Fax: (+49) 3328 4784-30

Microchip Frequency Technology GmbH reserves the right to make changes to the product(s) and/or information contained herein without notice. No liability is assumed as a result of their use or application. No rights under any patent accompany the sale of any such product(s) or information.

Filter characteristic

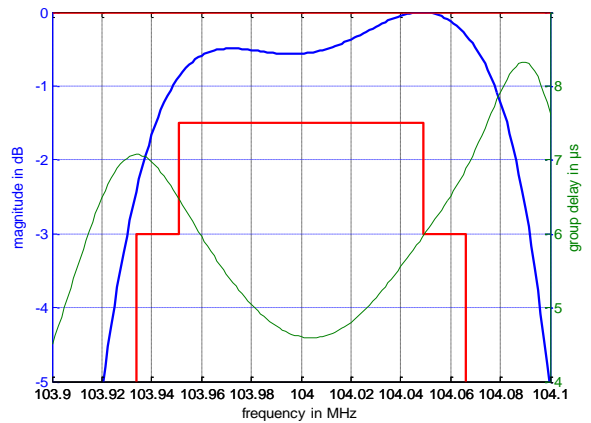
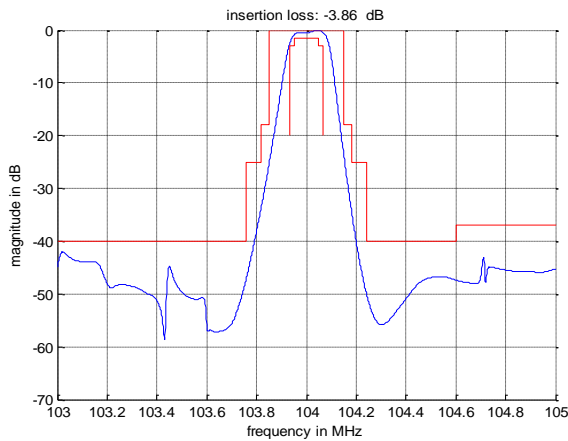

Construction and pin connection

(All dimensions in mm)

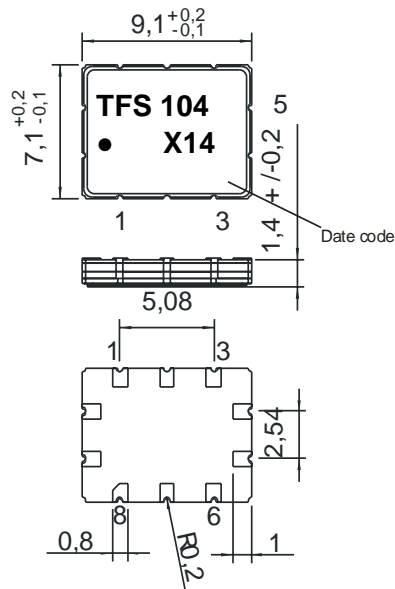

- 1 Input
- 2 Input RF Return
- 3 External Coil
- 4 Ground
- 5 Ground
- 6 Output
- 7 Output RF Return
- 8 Ground
- 9 Ground
- 10 Ground

Date code: Year + week
 X 2009
 A 2010
 B 2011
 ...

50 Ohm Test circuit

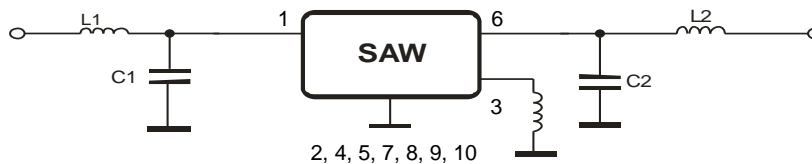

Microchip Frequency Technology GmbH
 Potsdamer Straße 18
 D 14 513 TELTOW / Germany
 Tel: (+49) 3328 4784-0 / Fax: (+49) 3328 4784-30

Microchip Frequency Technology GmbH reserves the right to make changes to the product(s) and/or information contained herein without notice. No liability is assumed as a result of their use or application. No rights under any patent accompany the sale of any such product(s) or information.

Stability characteristics, reliability

After the following tests the filter shall meet the whole specification:

1. Shock: 500g, 1 ms, half sine wave, 3 shocks each plane;
DIN IEC 68 T2 - 27
2. Vibration: 10 Hz to 500 Hz, 0,35 mm or 5 g respectively, 1 octave per min, 10 cycles per plan, 3 plans;
DIN IEC 68 T2 - 6
3. Change of temperature: -55 °C to 125°C / 30 min. each / 10 cycles
DIN IEC 68 part 2 – 14 Test N
4. Resistance to solder heat (reflow): reflow possible: three times max. ;
for temperature conditions refer to the attached "Air reflow temperature conditions" on page 4;

This filter is RoHS compliant (2002/95/EG, 2005/618/EG)

Packing

Tape & Reel: IEC 286 – 3, with exception of value for N and minimum bending radius;
tape type II, embossed carrier tape with top cover tape on the upper side;

max. pieces of filters per reel:	2000
reel of empty components at start:	min. 300 mm
reel of empty components at start including leader:	min. 500 mm
trailer:	min. 300 mm

Tape (all dimensions in mm)

- W : 16,00 ± 0,3
- Po : 4,00 ± 0,1
- Do : 1,50 +0,1/-0
- E : 1,75 ± 0,10
- F : 7,50 ± 0,10
- G(min) : 0,60
- P2 : 2,00 ± 0,1
- P1 : 12,00 ± 0,1
- D1(min) : 1,50 +0,1/-0
- Ao : 7,60 ± 0,10
- Bo : 9,60 ± 0,10
- Ct : 13,5

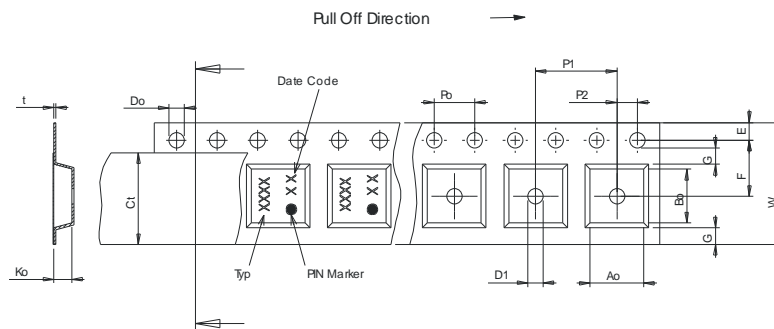

Reel (all dimensions in mm)

- A : 330
- W1 : 16,4
- W2(max) : 22,4
- N(min) : 50
- C : 13,0

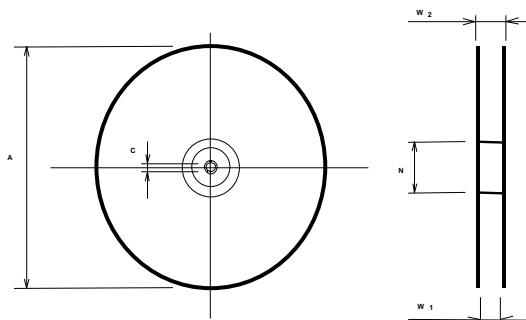

The minimum bending radius is 45 mm.

Microchip Frequency Technology GmbH
Potsdamer Straße 18
D 14 513 TELTOW / Germany
Tel: (+49) 3328 4784-0 / Fax: (+49) 3328 4784-30

Microchip Frequency Technology GmbH reserves the right to make changes to the product(s) and/or information contained herein without notice. No liability is assumed as a result of their use or application. No rights under any patent accompany the sale of any such product(s) or information.

Air reflow temperature conditions

Conditions	Exposure
Average ramp-up rate (30°C to 217°C)	less than 3°C/second
> 100°C	between 300 and 600 seconds
> 150°C	between 240 and 500 seconds
> 217°C	between 30 and 150 seconds
Peak temperature	max. 260°C
Time within 5°C of actual peak temperature	between 10 and 30 seconds
Cool-down rate (Peak to 50°C)	less than 6°C/second
Time from 30°C to Peak temperature	no greater than 300 seconds

Chip-mount air reflow profile

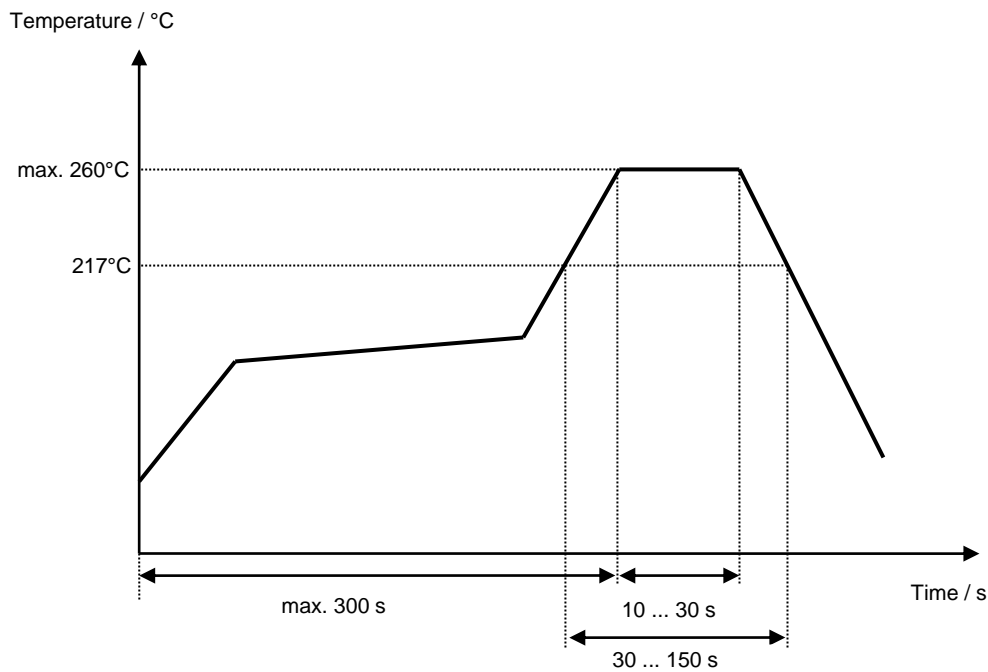

Microchip Frequency Technology GmbH
Potsdamer Straße 18
D 14 513 TELTOW / Germany
Tel: (+49) 3328 4784-0 / Fax: (+49) 3328 4784-30

Microchip Frequency Technology GmbH reserves the right to make changes to the product(s) and/or information contained herein without notice. No liability is assumed as a result of their use or application. No rights under any patent accompany the sale of any such product(s) or information.

Microchip**Filter specification****TFS 104****5/5****History**

Version	Reason of Changes	Name	Date
1.0	Generation of development specification	Strehl	29.02.2008
1.1	Change limit lines in stop band Add test circuit and filter characteristic Change company name from TeleFilter to Vectron International	Dr. Wall	30.06.2008
1.2	Generation of filter specification Added typical values	Martens	24.07.2008
1.3	Corrected typo in relative attenuation limit line scheme	Martens	06.08.2008
1.4	Added input power level requirement	Martens	01.04.2009

Microchip Frequency Technology GmbH
Potsdamer Straße 18
D 14 513 TELTOW / Germany
Tel: (+49) 3328 4784-0 / Fax: (+49) 3328 4784-30

Microchip Frequency Technology GmbH reserves the right to make changes to the product(s) and/or information contained herein without notice. No liability is assumed as a result of their use or application. No rights under any patent accompany the sale of any such product(s) or information.