

Microchip	Filter specification	TFS 127F	1/5
------------------	-----------------------------	-----------------	------------

Measurement condition

Ambient temperature:	23	°C
Input power level:	0	dBm
Terminating impedance: *		
Input:	62 Ω	-9.6 pF
Output:	62 Ω	-9.6 pF

Characteristics

Remark:

The reference level for the relative attenuation a_{rel} of the TFS127F is the minimum of the pass band attenuation a_{min} . The minimum of the pass band attenuation a_{min} is defined as the insertion loss a_e . The centre frequency f_c is the arithmetic mean value of the upper and lower frequencies at the 3 dB filter attenuation level relative to the insertion loss a_e . The temperature coefficient of frequency TC_f is valid for both the reference frequency f_c and the frequency response of the filter in the operating temperature range. The frequency shift of the filter in the operating temperature range is not included in the production tolerance scheme.

D a t a		typ. value		tolerance / limit		
Insertion loss (reference level)	a_e	20.3	dB	max.	22	dB
Nominal frequency	f_N	-			127.5	MHz
Centre frequency at ambient temperature	f_c	127.5	MHz	±	0.15	MHz
Passband	PB			f_c ±	9.5	MHz
Pass band ripple	p-p	0.4	dB	max.	1.0	dB
Bandwidth	BW					
1 dB		20.5	MHz	min.	19	MHz
3 dB		20.9	MHz	min.	20.75	MHz
35 dB		22.2	MHz	max.	22.38	MHz
50 dB		22.4	MHz	max.	24.6	MHz
Relative attenuation	a_{rel}					
f_c ... f_c ± 9.5 MHz		0.4	dB	max.	1.0	dB
f_c ± 9.50 MHz ... f_c ± 10.375 MHz		2.3	dB	max.	3.0	dB
f_c ± 11.19 MHz ... f_c ± 12.3 MHz		48	dB	min.	35	dB
f_c ± 12.3 MHz ... f_c ± 50 MHz		54	dB	min.	50	dB
Group delay ripple within PB		54	ns	max.	100	ns
Absolute delay within PB***		1.9	µs	max.	2.2	µs
Input power		-	dBm	max.	13	dBm
Operating temperature range	OTR	-			-40 °C ... + 85 °C	
Storage temperature range		-			-55 °C ... + 125 °C	
Temperature coefficient of frequency	TC_f **	- 72	ppm/K		-	

*) The terminating impedances depend on parasitics and q-values of matching elements and the board used, and are to be understood as reference values only. Should there be additional questions do not hesitate to ask for an application note or contact our design team.

**) $\Delta f(\text{Hz}) = TC_f(\text{ppm/K}) \times (T - T_0) \times f_{T0}(\text{MHz})$

***) The average delay is measured in the time domain. This is the delay of the main peak in the time domain.

Generated: _____

Checked / Approved: _____

Microchip Frequency Technology GmbH
Potsdamer Straße 18
D 14 513 TELTOW / Germany
Tel: (+49) 3328 4784-0 / Fax: (+49) 3328 4784-30

Microchip Frequency Technology GmbH reserves the right to make changes to the product(s) and/or information contained herein without notice. No liability is assumed as a result of their use or application. No rights under any patent accompany the sale of any such product(s) or information.

Filter characteristic

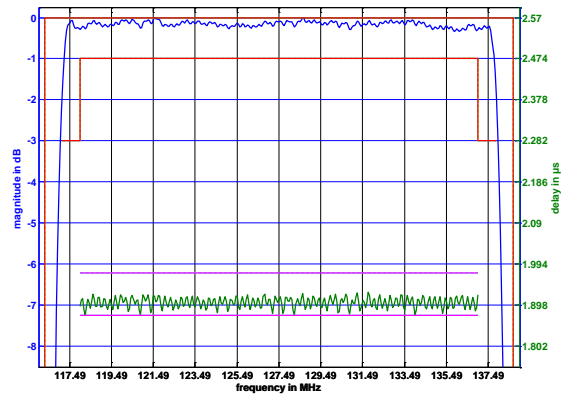
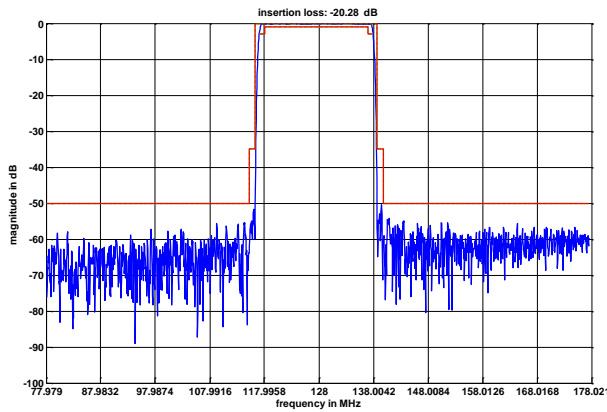

Construction and pin connection
(All dimensions in mm)

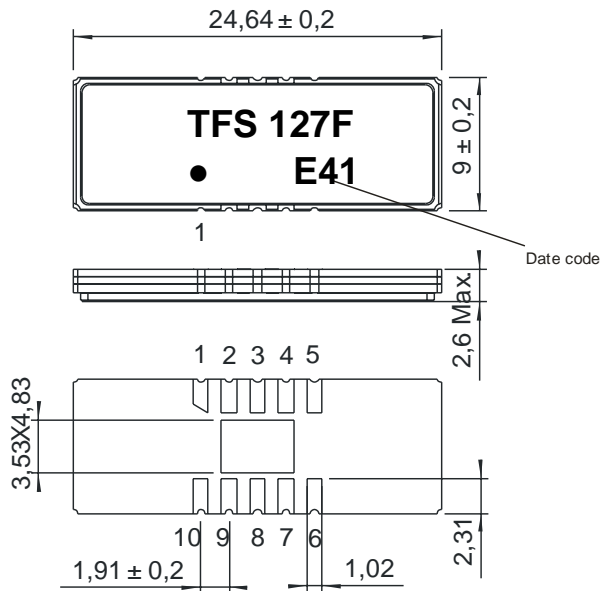

- 1 Input
- 2 Ground
- 3 Ground
- 4 Ground
- 5 Output RF Return
- 6 Output
- 7 Ground
- 8 Ground
- 9 Ground
- 10 Input RF Return

Date code: Year + week
 E 2014
 F 2015
 G 2016
 ...

50 Ohm Test circuit

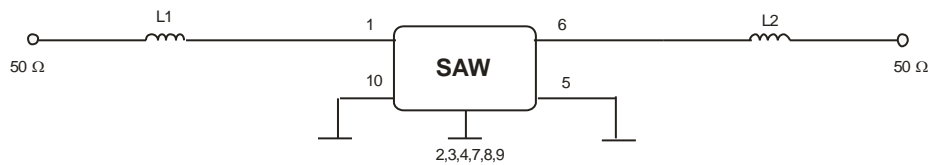

Microchip Frequency Technology GmbH
 Potsdamer Straße 18
 D 14 513 TELTOW / Germany
 Tel: (+49) 3328 4784-0 / Fax: (+49) 3328 4784-30

Microchip Frequency Technology GmbH reserves the right to make changes to the product(s) and/or information contained herein without notice. No liability is assumed as a result of their use or application. No rights under any patent accompany the sale of any such product(s) or information.

Stability characteristics, reliability

After the following tests the filter shall meet the whole specification:

1. Shock: 500g, 1 ms, half sine wave, 3 shocks each plane;
DIN IEC 68 T2 - 27
2. Vibration: 10 Hz to 500 Hz, 0,35 mm or 5 g respectively, 1 octave per min, 10 cycles per plane, 3 planes;
DIN IEC 68 T2 - 6
3. Change of temperature: -55 °C to 125°C / 15 min. each / 100 cycles
DIN IEC 68 part 2 – 14 Test N
4. Resistance to solder heat (reflow): reflow possible: three times max.;
for temperature conditions refer to the attached "Air reflow temperature conditions" on page 4;
5. ESD ANSI/ESD S20.20-1999, class 1A for HBM

This filter is RoHS compliant (2011/65/EU)

Packing

Tape & Reel: IEC 286 – 3, with exception of value for N and minimum bending radius;
tape type II, embossed carrier tape with top cover tape on the upper side;

max. pieces of filters per reel:	1000
reel of empty components at start:	min. 300 mm
reel of empty components at start including leader:	min. 500 mm
trailer:	min. 300 mm

Tape (all dimensions in mm)

- W : 44,00 ± 0,3
- Po : 4,00 ± 0,1
- Do : 1,50 +0,1/-0
- E : 1,75 ± 0,1
- F : 20,20 ± 0,15
- G(min) :
- P2 : 2,00 ± 0,15
- P1 : 16,00 ± 0,1
- D1(min) : 2,00
- Ao : 9,30 ± 0,1
- Bo : 24,90 ± 0,1
- Ct : 38,0 ± 0,1

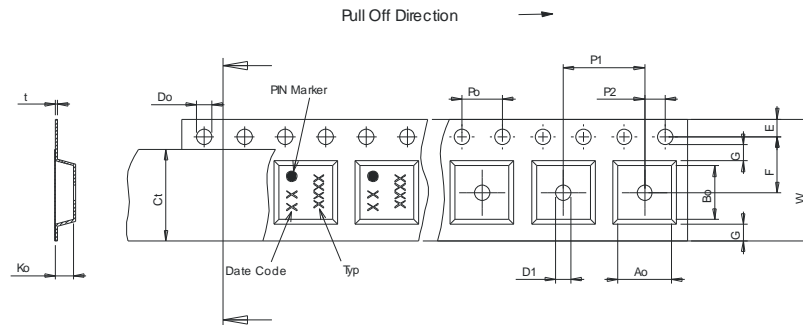

Reel (all dimensions in mm)

- A : 330
- W1 : 44,4 +2/-0
- W2(max) : 50,4
- N(min) : 100
- C : 13,0 +0,5/-0,2

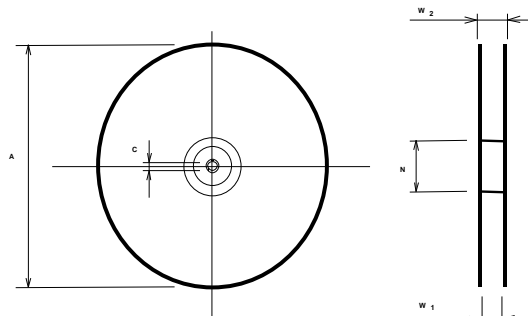

The minimum bending radius is 45 mm.

Microchip Frequency Technology GmbH
Potsdamer Straße 18
D 14 513 TELTOW / Germany
Tel: (+49) 3328 4784-0 / Fax: (+49) 3328 4784-30

Microchip Frequency Technology GmbH reserves the right to make changes to the product(s) and/or information contained herein without notice. No liability is assumed as a result of their use or application. No rights under any patent accompany the sale of any such product(s) or information.

Air reflow temperature conditions

Conditions	Exposure
Average ramp-up rate (30°C to 217°C)	less than 3°C/second
> 100°C	between 300 and 600 seconds
> 150°C	between 240 and 500 seconds
> 217°C	between 30 and 150 seconds
Peak temperature	max. 260°C
Time within 5°C of actual peak temperature	between 10 and 30 seconds
Cool-down rate (Peak to 50°C)	less than 6°C/second
Time from 30°C to Peak temperature	no greater than 300 seconds

Chip-mount air reflow profile

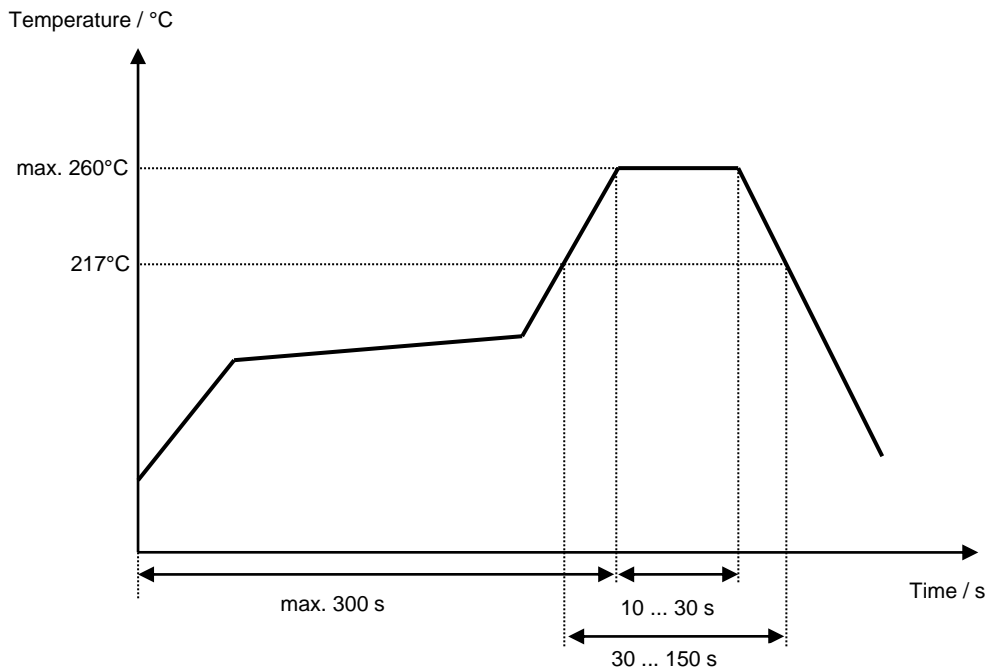

Microchip**Filter specification****TFS 127F****5/5**

History

Version	Reason of Changes	Name	Date
1.0	- Generation of development specification	TCUK	22.07.2014
1.1	- Add plots & typ values and move to filter specification	TCUK	03.12.2014

Microchip Frequency Technology GmbH
Potsdamer Straße 18
D 14 513 TELTOW / Germany
Tel: (+49) 3328 4784-0 / Fax: (+49) 3328 4784-30

Microchip Frequency Technology GmbH reserves the right to make changes to the product(s) and/or information contained herein without notice. No liability is assumed as a result of their use or application. No rights under any patent accompany the sale of any such product(s) or information.