

**Microchip** **Filter specification** **TFS 1220M** **1/5**

**Measurement condition**

|                        |    |     |
|------------------------|----|-----|
| Ambient temperature:   | 22 | °C  |
| Input power level:     | 0  | dBm |
| Terminating impedance: |    |     |
| Input:                 | 50 | Ω   |
| Output:                | 50 | Ω   |

**Characteristics**

Remark:

The maximum attenuation in the pass band is defined as the insertion loss  $a_e$ . The nominal frequency  $f_N$  is fixed at 1220.0 MHz without any tolerance or limit. The values of absolute attenuation  $a_{abs}$  are guaranteed for the whole operating temperature range. The frequency shift of the filter in the operating temperature range is included in the production tolerance scheme.

| <b>D a t a</b>                              | <b>typ. value</b> |           | <b>tolerance / limit</b> |                   |     |
|---|-------------------|-----------|--------------------------|-------------------|-----|
| <b>Insertion loss</b>                       | $a_e$             | 4.0 dB    | max.                     | 4.9               | dB  |
| <b>Nominal frequency</b>                    | $f_N$             |           |                          | 1220.0            | MHz |
| <b>Passband</b>                             |                   |           | $f_N \pm$                | 3                 | MHz |
| <b>Pass band ripple</b>                     |                   | 0.1 dB    | max.                     | 1.5               | dB  |
| <b>Absolute attenuation</b>                 | $a_{abs}$         |           |                          |                   |     |
| 0.3 MHz ... 1180 MHz                        | 1180 MHz          | 53 dB     | min.                     | 45                | dB  |
| 1180 MHz ... 1200 MHz                       | 1200 MHz          | 45 dB     | min.                     | 30                | dB  |
| 1200 MHz ... 1210 MHz                       | 1210 MHz          | 33 dB     | min.                     | 16                | dB  |
| 1210 MHz ... 1212 MHz                       | 1212 MHz          | 21 dB     | min.                     | 9                 | dB  |
| 1228 MHz ... 1230 MHz                       | 1230 MHz          | 13 dB     | min.                     | 9                 | dB  |
| 1230 MHz ... 1240 MHz                       | 1240 MHz          | 20 dB     | min.                     | 16                | dB  |
| 1240 MHz ... 1400 MHz                       | 1400 MHz          | 51 dB     | min.                     | 45                | dB  |
| 1400 MHz ... 1700 MHz                       | 1700 MHz          | 46 dB     | min.                     | 40                | dB  |
| 1700 MHz ... 2000 MHz                       | 2000 MHz          | 42 dB     | min.                     | 35                | dB  |
| <b>Group delay ripple within PB</b>         |                   | 19 ns     | max.                     | 100               | ns  |
| <b>Operating temperature range</b>          | OTR               |           |                          | 22 °C             |     |
| <b>Storage temperature range</b>            |                   |           |                          | -45 °C ... +90 °C |     |
| <b>Temperature coefficient of frequency</b> | $TC_f^*$          | -40 ppm/K |                          | -                 |     |
| <b>Input power level</b>                    |                   | -         | max.                     | 10                | dBm |

\*)  $\Delta f_c(\text{Hz}) = TC_f(\text{ppm/K}) \times (T - T_A) \times f_{cat}(\text{MHz})$

**Generated:**

**Checked / Approved:**

**Microchip Frequency Technology GmbH**  
**Potsdamer Straße 18**  
**D 14 513 TELTOW / Germany**  
**Tel: (+49) 3328 4784-0 / Fax: (+49) 3328 4784-30**

Microchip Frequency Technology GmbH reserves the right to make changes to the product(s) and/or information contained herein without notice. No liability is assumed as a result of their use or application. No rights under any patent accompany the sale of any such product(s) or information.

**Filter characteristic**

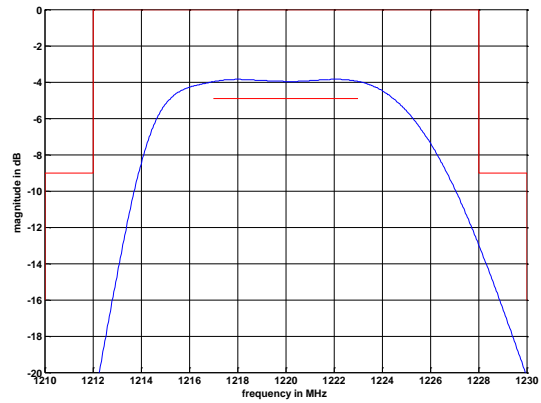
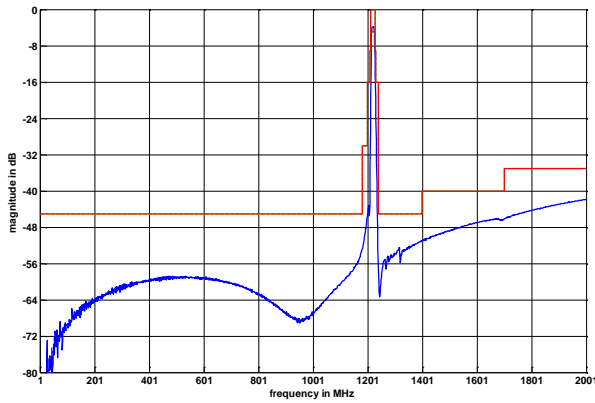

**Construction and pin connection**

(All dimensions in mm)

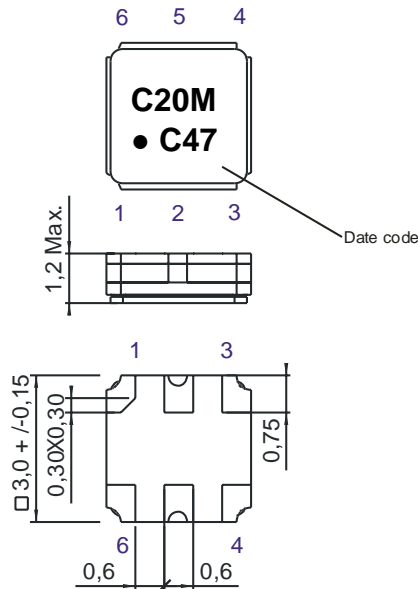

- 1 Ground
- 2 Input
- 3 Ground
- 4 Ground
- 5 Output
- 6 Ground

Date code: Year + week  
 C 2012  
 D 2013  
 E 2014  
 ...

**50 Ω Test circuit**

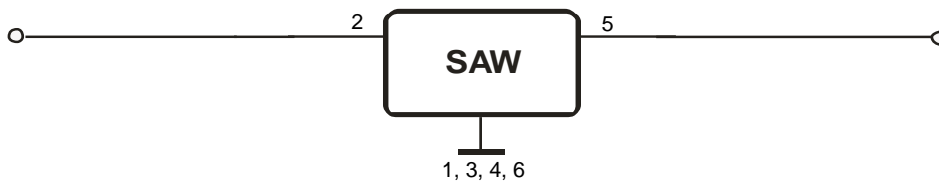

**Microchip Frequency Technology GmbH**  
 Potsdamer Straße 18  
 D 14 513 TELTOW / Germany  
 Tel: (+49) 3328 4784-0 / Fax: (+49) 3328 4784-30

Microchip Frequency Technology GmbH reserves the right to make changes to the product(s) and/or information contained herein without notice. No liability is assumed as a result of their use or application. No rights under any patent accompany the sale of any such product(s) or information.

**Stability characteristics**

After the following tests the filter shall meet the whole specification:

1. Shock: 500g, 18 ms, half sine wave, 3 shocks each plane;  
DIN IEC 68 T2 - 27
2. Vibration: 10 Hz to 500 Hz, 0,35 mm or 5 g respectively, 1 octave per min, 10 cycles per plan, 3 plans;  
DIN IEC 68 T2 - 6
3. Change of temperature: -55 °C to 125°C / 30 min. each / 10 cycles  
DIN IEC 68 part 2 – 14 Test N
4. Resistance to solder heat (reflow): reflow possible: twice max.;  
for temperature conditions refer to the attached "Air reflow temperature conditions" on page 4;

**Packing**

Tape & Reel: IEC 286 – 3, with exception of value for N and minimum bending radius;  
tape type II, embossed carrier tape with top cover tape on the upper side;

|   |             |
|---|-------------|
| max. pieces of filters per reel:                    | 3000        |
| reel of empty components at start:                  | min. 300 mm |
| reel of empty components at start including leader: | min. 500 mm |
| trailer:  | min. 300 mm |

**Tape (all dimensions in mm)**

- W : 8,00 ± 0,3
- Po : 4,00 ± 0,1
- Do : 1,50 +0,1/-0
- E : 1,75 ± 0,1
- F : 3,50 ± 0,05
- G(min) : 0,75
- P2 : 2,00 ± 0,05
- P1 : 4,00 ± 0,1
- D1(min) : 1,50
- Ao : 3,25 ± 0,1
- Bo : 3,25 ± 0,1
- Ct : 5,3 ± 0,1

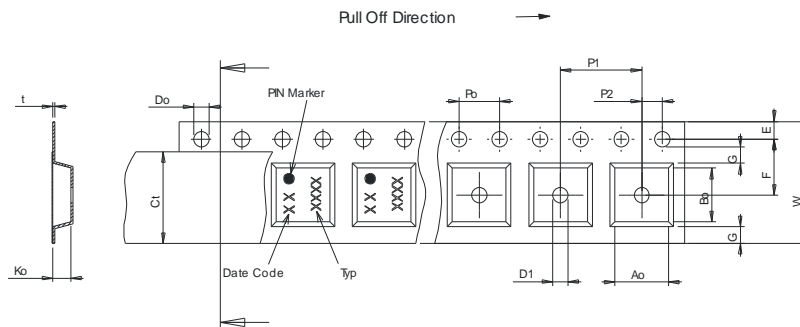

**Reel (all dimensions in mm)**

- A : 180
- W1 : 8,4 +1,5/-0
- W2(max) : 14,4
- N(min) : 60
- C : 13,0 ± 0,2

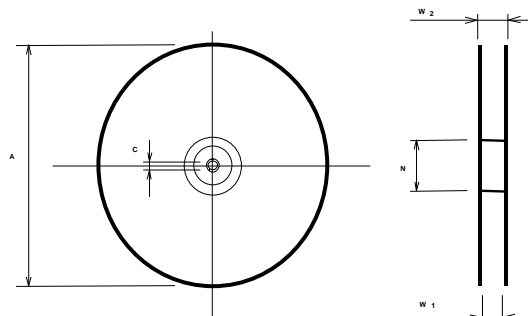

The minimum bending radius is 45 mm.

**Microchip Frequency Technology GmbH**  
**Potsdamer Straße 18**  
**D 14 513 TELTOW / Germany**  
**Tel: (+49) 3328 4784-0 / Fax: (+49) 3328 4784-30**

Microchip Frequency Technology GmbH reserves the right to make changes to the product(s) and/or information contained herein without notice. No liability is assumed as a result of their use or application. No rights under any patent accompany the sale of any such product(s) or information.

**Air reflow temperature conditions**

| <b>Conditions</b>                          | <b>Exposure</b>             |
|--|-----------------------------|
| Average ramp-up rate (30°C to 217°C)       | less than 3°C/second        |
| > 100°C                                    | between 300 and 600 seconds |
| > 150°C                                    | between 240 and 500 seconds |
| > 217°C                                    | between 30 and 150 seconds  |
| Peak temperature                           | max. 260°C                  |
| Time within 5°C of actual peak temperature | between 10 and 30 seconds   |
| Cool-down rate (Peak to 50°C)              | less than 6°C/second        |
| Time from 30°C to Peak temperature         | no greater than 300 seconds |

**Chip-mount air reflow profile**

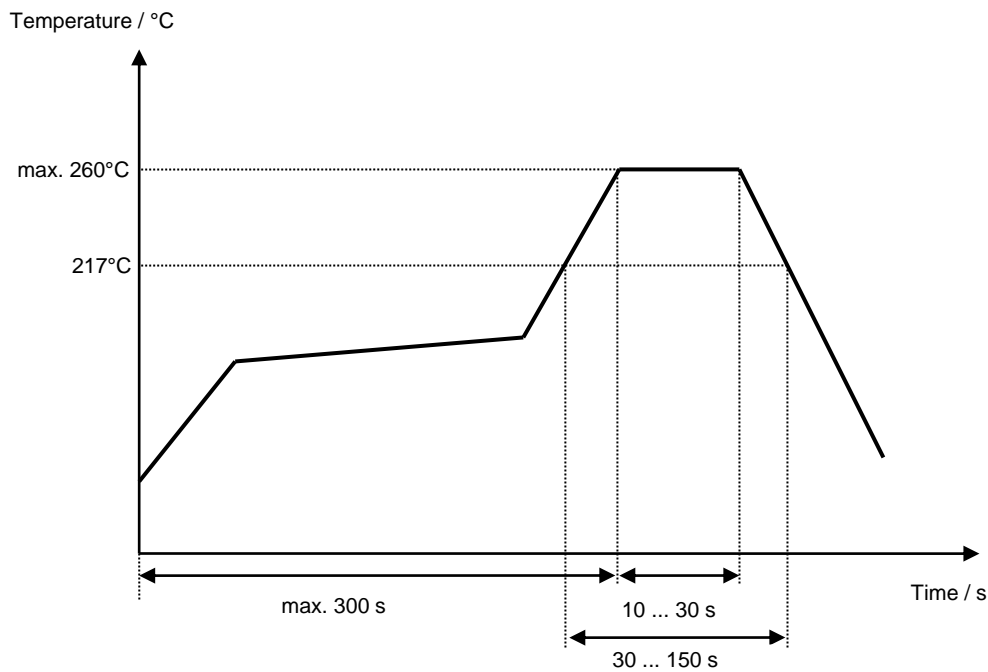

---

**Microchip****Filter specification****TFS 1220M****5/5**

---

**History**

| <b>Version</b> | <b>Reason of Changes</b>                 | <b>Name</b>    | <b>Date</b> |
|----------------|--|----------------|-------------|
| 1.0            | Generation of development specification. | S. Springfeldt | 04.07.2012  |
| 1.1            | Generation of filter specification.      | C. Schönbein   | 20.11.2012  |

---

**Microchip Frequency Technology GmbH**  
**Potsdamer Straße 18**  
**D 14 513 TELTOW / Germany**  
**Tel: (+49) 3328 4784-0 / Fax: (+49) 3328 4784-30**

---

Microchip Frequency Technology GmbH reserves the right to make changes to the product(s) and/or information contained herein without notice. No liability is assumed as a result of their use or application. No rights under any patent accompany the sale of any such product(s) or information.