

Microchip

Filter specification

TFS 869M

1/5

Measurement condition

Ambient temperature:	23	°C
Input power level:	0	dBm
Terminating impedance: *		
Input:	50 Ω	
Output:	50 Ω	
Source:	529.8 Ω -1.2 pF	
Load:	508.4 Ω -1.1 pF	

Characteristics

Remark:

The reference level for the relative attenuation a_{rel} of TFS869M is the maximum of the passband attenuation a_e within PB1. The nominal frequency f_{N1} is fixed at 869.2125 MHz without any tolerance. The values of the relative attenuation a_{rel} are guaranteed over the whole operating temperature range. The frequency shift of the filter within the operating temperature range is included in the production tolerance scheme.

Data	typ. value	tolerance / limit
Nominal frequency 1	f_{N1} - dB	869.2125 MHz
Passband 1	PB1 -	$f_{N1} \pm 12.5$ kHz
Insertion loss within PB1 (reference level)	a_e 2.4 dB	max. 3.0 dB
Passband variation within PB1	0.1 dB	max. 1.0 dB
Nominal frequency 2	f_{N2} -	869.2375 MHz
Passband 2	PB2 -	$f_{N2} \pm 12.5$ kHz
Insertion loss within PB2	2.4 dB	max. 3.5 dB
Passband variation within PB2	0.1 dB	max. 1.5 dB
Relative attenuation	a_{rel}	
1.0000 MHz ... 852.0000 MHz	36 dB	min. 15 dB
852.0000 MHz ... 862.0000 MHz	32 dB	min. 25 dB
862.0000 MHz ... 867.2125 MHz	18 dB	min. 15 dB
871.2125 MHz ... 880.0000 MHz	18 dB	min. 15 dB
880.0000 MHz ... 915.0000 MHz	35 dB	min. 25 dB
Input power level	** -	max. 8 dBm
	*** -	max. 11 dBm
	**** -	max. 11 dBm
	***** -	max. 14 dBm
	***** -	max. 23 dBm
	***** -	max. 26 dBm
Operating temperature range	OTR -	- 10 °C ... + 55 °C
Storage temperature range	-	- 40 °C ... + 85 °C
Frequency inversion temperature	40 °C	
Temperature coefficient of frequency	TC_f ***** -0.044 ppm/K ²	

*) The terminating impedances depend on parasitics and q-values of matching elements and the board used, and are to be understood as reference values only. Should there be additional questions do not hesitate to ask for an application note or contact our design team.

***) operating temperature = 55°C, duty cycle = 1 : 1

****) operating temperature = 25°C, duty cycle = 1 : 1

*****) operating temperature = 55°C, duty cycle = 1 : 8.4

*****) operating temperature = 25°C, duty cycle = 1 : 8.4

*****) operating temperature = 55°C, duty cycle = 1 : 1, frequency range = 852 ... 862 MHz

*****) operating temperature = 55°C, duty cycle = 1 : 8.4, frequency range = 880 ... 915 MHz

*****) $\Delta f_c(\text{Hz}) = TC_f (\text{ppm/K}^2) \times (T - T_0)^2 \times f_{r0} (\text{MHz})$

Generated:

Checked / Approved:

Microchip Frequency Technology GmbH
Potsdamer Straße 18
D 14 513 TELTOW / Germany
Tel: (+49) 3328 4784-0 / Fax: (+49) 3328 4784-30

Microchip Frequency Technology GmbH reserves the right to make changes to the product(s) and/or information contained herein without notice. No liability is assumed as a result of their use or application. No rights under any patent accompany the sale of any such product(s) or information.

Filter characteristic

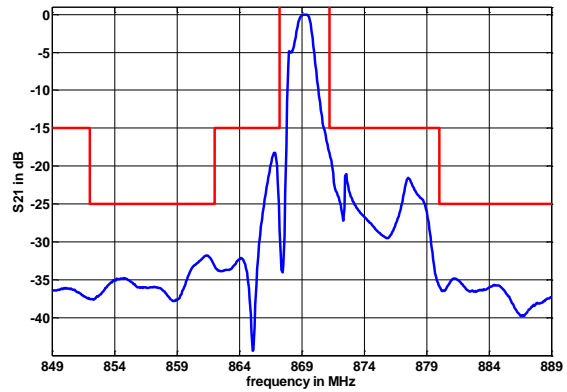
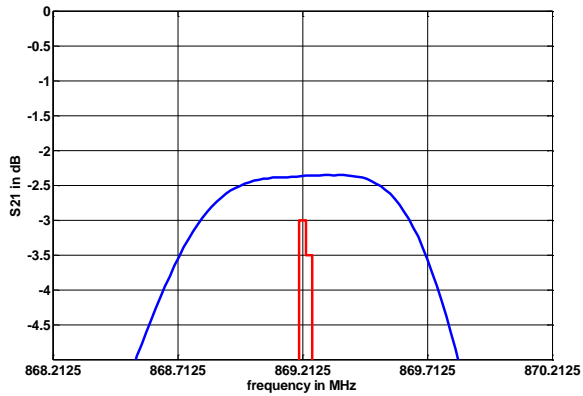

Construction and pin connection

(All dimensions in mm)

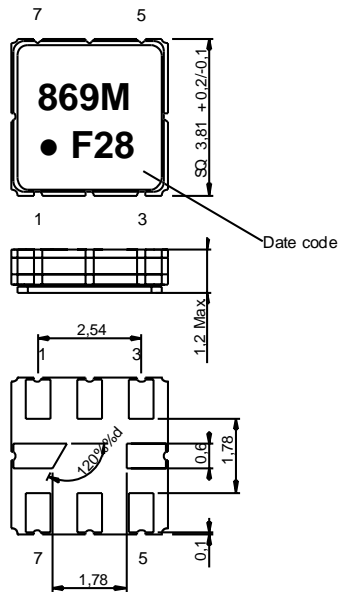

- 1 Ground
- 2 Input
- 3 Ground
- 4 Ground
- 5 Ground
- 6 Output
- 7 Ground
- 8 Ground

Date code: Year + week
 F 2015
 G 2016
 H 2017
 ...

50 Ohm Test circuit

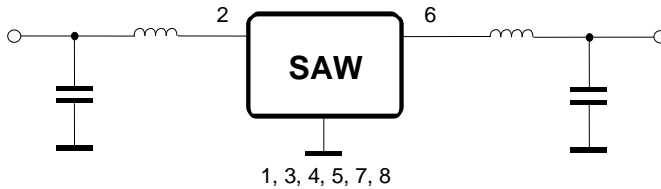

Microchip Frequency Technology GmbH
 Potsdamer Straße 18
 D 14 513 TELTOW / Germany
 Tel: (+49) 3328 4784-0 / Fax: (+49) 3328 4784-30

Microchip Frequency Technology GmbH reserves the right to make changes to the product(s) and/or information contained herein without notice. No liability is assumed as a result of their use or application. No rights under any patent accompany the sale of any such product(s) or information.

Stability characteristics, reliability

After the following tests the filter shall meet the whole specification:

1. Shock: 500g, 1 ms, half sine wave, 3 shocks each plane;
DIN IEC 68 T2 - 27
2. Vibration: 10 Hz to 500 Hz, 0,35 mm or 5 g respectively, 1 octave per min, 10 cycles per plane, 3 planes; DIN IEC 68 T2 - 6
3. Change of temperature: -55 °C to 125°C / 15 min. each / 100 cycles
DIN IEC 68 part 2 – 14 Test N
4. Resistance to solder heat (reflow): reflow possible: three times max.;
for temperature conditions, see page 4: "Air reflow temperature conditions"
5. ESD ANSI/ESD S20.20-1999, class 1A for HBM

This filter is RoHS compliant (2011/65/EU)

Packing

Tape & Reel: IEC 286 – 3, with exception of value for N and minimum bending radius;
tape type II, embossed carrier tape with top cover tape on the upper side;

max. pieces of filters per reel:	3000
reel of empty components at start:	min. 300 mm
reel of empty components at start including leader:	min. 500 mm
trailer:	min. 300 mm

Tape (all dimensions in mm)

- W : 12,00 ± 0,3
- Po : 4,00 ± 0,1
- Do : 1,50 +0,1/-0
- E : 1,75 ± 0,1
- F : 5,50 ± 0,05
- G(min) : 0,75
- P2 : 2,00 ± 0,05
- P1 : 8,00 ± 0,1
- D1(min) : 1,50
- Ao : 4,30 ± 0,1
- Bo : 4,30 ± 0,1
- Ct : 9,2 ± 0,1

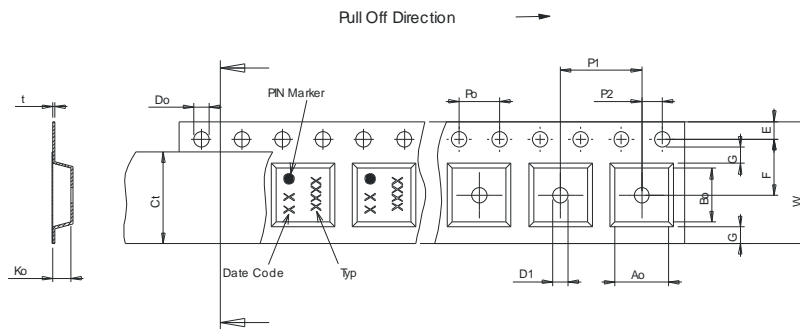

Reel (all dimensions in mm)

- A : 330 or 180
- W1 : 12,4 +2/-0
- W2(max) : 18,4
- N(min) : 50
- C : 13,0 +0,5/-0,2

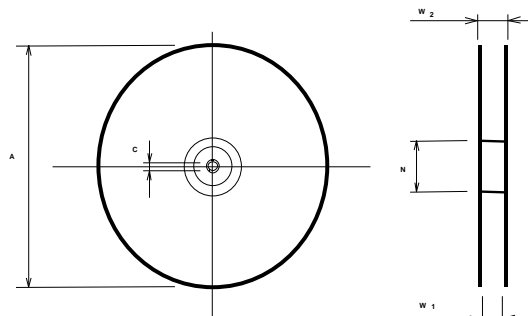

The minimum bending radius is 45 mm.

Microchip Frequency Technology GmbH
Potsdamer Straße 18
D 14 513 TELTOW / Germany
Tel: (+49) 3328 4784-0 / Fax: (+49) 3328 4784-30

Microchip Frequency Technology GmbH reserves the right to make changes to the product(s) and/or information contained herein without notice. No liability is assumed as a result of their use or application. No rights under any patent accompany the sale of any such product(s) or information.

Air reflow temperature conditions

Conditions	Exposure
Average ramp-up rate (30°C to 217°C)	less than 3°C/second
> 100°C	between 300 and 600 seconds
> 150°C	between 240 and 500 seconds
> 217°C	between 30 and 150 seconds
Peak temperature	max. 260°C
Time within 5°C of actual peak temperature	between 10 and 30 seconds
Cool-down rate (Peak to 50°C)	less than 6°C/second
Time from 30°C to Peak temperature	no greater than 300 seconds

Chip-mount air reflow profile

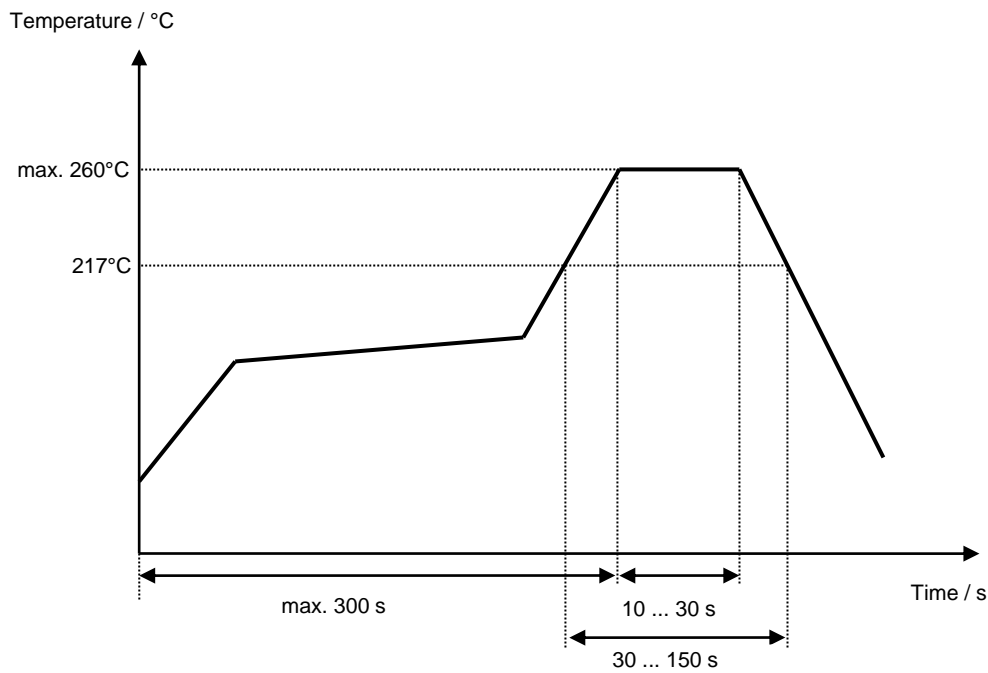

Microchip Frequency Technology GmbH
Potsdamer Straße 18
D 14 513 TELTOW / Germany
Tel: (+49) 3328 4784-0 / Fax: (+49) 3328 4784-30

Microchip Frequency Technology GmbH reserves the right to make changes to the product(s) and/or information contained herein without notice. No liability is assumed as a result of their use or application. No rights under any patent accompany the sale of any such product(s) or information.

Microchip**Filter specification****TFS 869M****5/5**

History

Version	Reason of Changes	Name	Date
1.0	- Generation of development specification	Molke	15.01.2014
2.0	- Definition of second passband - Update of relative attenuation table - Specification of additional input power levels - Change of matching networks	Molke	09.05.2014
2.1	- Change from development spec to filter spec - Matching networks corrected - Typical values added - Filter characteristic added	Molke	06.07.2015

Microchip Frequency Technology GmbH
Potsdamer Straße 18
D 14 513 TELTOW / Germany
Tel: (+49) 3328 4784-0 / Fax: (+49) 3328 4784-30

Microchip Frequency Technology GmbH reserves the right to make changes to the product(s) and/or information contained herein without notice. No liability is assumed as a result of their use or application. No rights under any patent accompany the sale of any such product(s) or information.