

Microchip

Filter specification

TFS 90B

1/5

Measurement condition

Ambient temperature T_A :	23	°C
Input power level:	0	dBm
Terminating impedance: *		
Input:	1000 Ω	-18.0 pF
Output:	900 Ω	-17.9 pF

Characteristics

Remark:

The nominal frequency f_N is fixed at 90.0 MHz. The insertion loss a_e is defined as loss value determined at f_N . Reference level for the relative attenuation a_{rel} of the TFS 90B is the insertion loss a_e . The centre frequency f_C is the arithmetic mean value of the upper and lower frequencies at the 2 dB filter attenuation level relative to the insertion loss a_e . All specified data are met within the operating temperature range.

D a t a		typ. value		tolerance / limit	
Insertion loss (reference level)		a_e	10.9 dB	max.	13.0 dB
Nominal frequency		f_N	-		90.0 MHz
Centre frequency		f_C	90.0 MHz		-
Passband		PB	-	$f_N \pm$	1.8 MHz
Pass band ripple	p-p		0.7 dB	max.	3 dB
Bandwidth					
1 dB			3.8 MHz		-
3 dB			4.2 MHz		-
Relative attenuation					
		a_{rel}			
f_N		$f_N \pm 1.5$ MHz	0.3 dB	max.	1.5 dB
$f_N \pm 1.5$ MHz		$f_N \pm 1.8$ MHz	0.6 dB	max.	3 dB
$f_N - 80$ MHz		$f_N - 15$ MHz	48 dB	min.	40 dB
$f_N \pm 15$ MHz		$f_N \pm 10$ MHz	38 dB	min.	30 dB
$f_N \pm 10$ MHz		$f_N \pm 6$ MHz	30 dB	min.	25 dB
$f_N \pm 6$ MHz		$f_N \pm 2.5$ MHz	13 dB	min.	6 dB
$f_N + 15$ MHz		$f_N + 80$ MHz	44 dB	min.	40 dB
$f_N + 80$ MHz		$f_N + 910$ MHz	38 dB	min.	30 dB
Group delay		at f_N	0.65 μ s	max.	0.75 μ s
Group delay variation		in $f_N \pm 1.2$ MHz	p-p	80 ns	max. 140 ns
Group delay variation		in PB	p-p	100 ns	max. 180 ns
Intermodulation **			42 dBm	min.	30 dBm
Input power level			-	max.	6 dBm
Operating temperature range		OTR	-		-40 °C..... +85 °C
Storage temperature range			-		-55 °C..... +125 °C
Temperature coefficient of frequency		TC_f ***	-33 ppm/K		-

*) The terminating impedances depend on parasitics and q-values of matching elements and the board used, and are to be understood as reference values only. Should there be additional questions do not hesitate to ask for an application note or contact our design team.

**) f_{in1} = 89.4 MHz; f_{in2} = 89.7 MHz; P_{in} = 0 dBm $f_{measurement}$ = 90.0 MHz

***) $\Delta f = TC_f(T - T_A)f_N$

Generated:

Checked / Approved:

Microchip Frequency Technology GmbH
Potsdamer Straße 18
D 14 513 TELTOW / Germany
Tel: (+49) 3328 4784-0 / Fax: (+49) 3328 4784-30

Microchip Frequency Technology GmbH reserves the right to make changes to the product(s) and/or information contained herein without notice. No liability is assumed as a result of their use or application. No rights under any patent accompany the sale of any such product(s) or information.

Filter characteristic

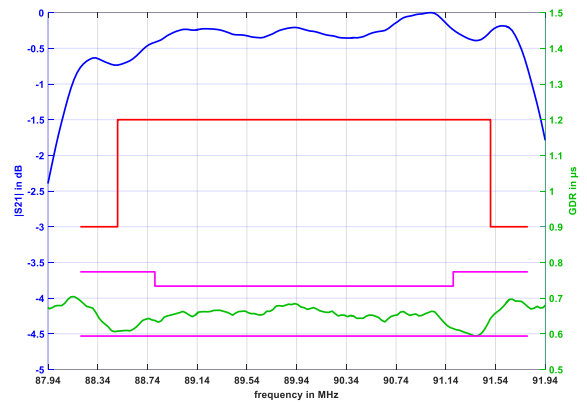
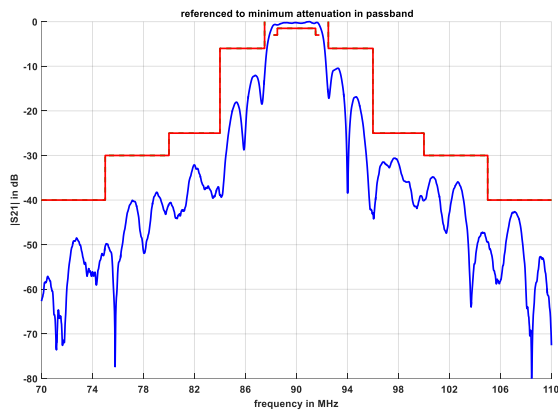

Construction and pin connection

(All dimensions in mm)

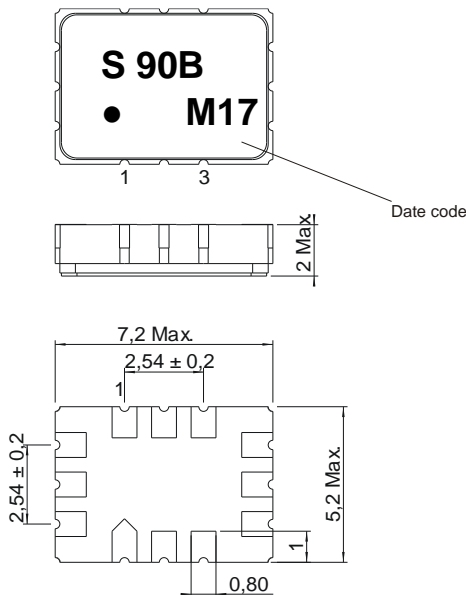

1	Input
2	Ground
3	Ground
4	Ground
5	Ground
6	Ground
7	Output
8	Ground
9	Ground
10	Ground
11	Ground
12	Ground

Date code: Year + week
 M 2020
 N 2021
 P 2022
 ...

50 Ω Test circuit

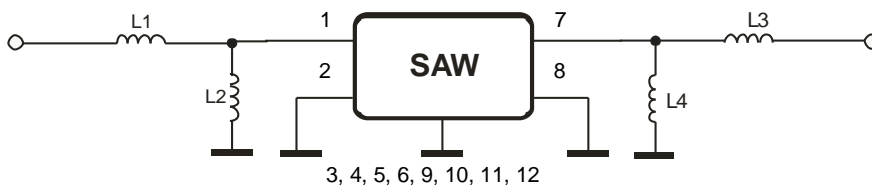

Microchip Frequency Technology GmbH
 Potsdamer Straße 18
 D 14 513 TELTOW / Germany
 Tel: (+49) 3328 4784-0 / Fax: (+49) 3328 4784-30

Microchip Frequency Technology GmbH reserves the right to make changes to the product(s) and/or information contained herein without notice. No liability is assumed as a result of their use or application. No rights under any patent accompany the sale of any such product(s) or information.

Stability characteristics, reliability

After the following tests the filter shall meet the whole specification:

1. Shock: 500 g, 1 ms, half sine wave, 3 shocks each plane;
DIN IEC 60068 T2 - 27
2. Vibration: 10 Hz to 2000 Hz, 0.35 mm or 5 g respectively, 1 octave per min, 10 cycles per plane, 3 planes; DIN IEC 60068 T2 - 6
3. Change of temperature: -55 °C to 125 °C / 15 min. each / 100 cycles
DIN IEC 60068 part 2 – 14 Test N
4. Resistance to solder heat (reflow): reflow possible: three times max.;
for temperature conditions refer to the attached "Air reflow temperature conditions" on page 4;
5. SAW devices are Electrostatic Discharge (ESD) sensitive devices.

This filter is RoHS compliant (2011/65/EU+2015/863/EU)

Packing

Tape & Reel: IEC 286 – 3, with exception of value for N and minimum bending radius;
tape type II, embossed carrier tape with top cover tape on the upper side;

reel of empty components at start: min. 300 mm
reel of empty components at start including leader: min. 500 mm
trailer: min. 300 mm

Tape (all dimensions in mm)

- W : 16.00 +0.3/-0.1
- Po : 4.00 ±0.1
- Do : 1.50 +0.1/-0
- E : 1.75 ±0.1
- F : 7.50 ±0.1
- G(min) : 0.75
- P2 : 2.00 ±0.1
- P1 : 8.00 ±0.1
- D1(min) : 1.50
- Ao : 5.40 ±0.1
- Bo : 7.60 ±0.1
- Ct : 13.30 ±0.1
- Ko : 2.00 ±0.1
- t : 0.30 ±0.05

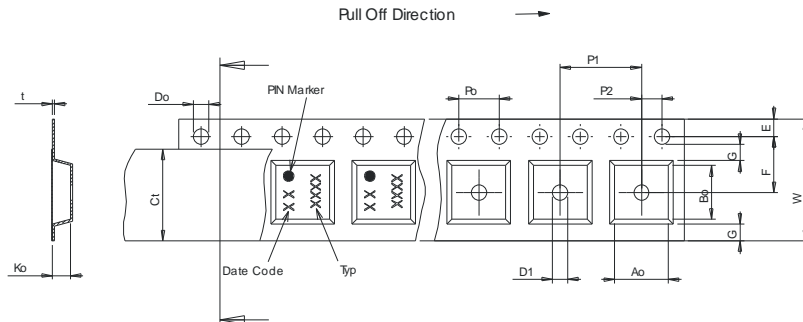

Reel (all dimensions in mm)

- A : 330 or 180
- W1 : 16.4 +2/-0
- W2(max) : 22.40
- N(min) : 50.00
- C : 13.0 +0.5/-0.2

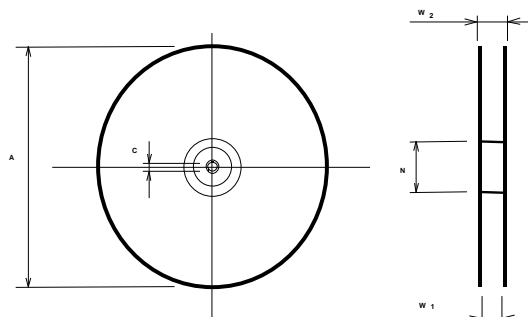

The minimum bending radius is 45 mm.

Microchip Frequency Technology GmbH
Potsdamer Straße 18
D 14 513 TELTOW / Germany
Tel: (+49) 3328 4784-0 / Fax: (+49) 3328 4784-30

Microchip Frequency Technology GmbH reserves the right to make changes to the product(s) and/or information contained herein without notice. No liability is assumed as a result of their use or application. No rights under any patent accompany the sale of any such product(s) or information.

Air reflow temperature conditions

Conditions	Exposure
Average ramp-up rate (30 °C to 217 °C)	less than 3 °C / second
> 100 °C	between 300 and 600 seconds
> 150 °C	between 240 and 500 seconds
> 217 °C	between 30 and 150 seconds
Peak temperature	max. 260 °C
Time within 5 °C of actual peak temperature	between 10 and 30 seconds
Cool-down rate (Peak to 50 °C)	less than 6 °C / second
Time from 30 °C to Peak temperature	no greater than 300 seconds

Chip-mount air reflow profile

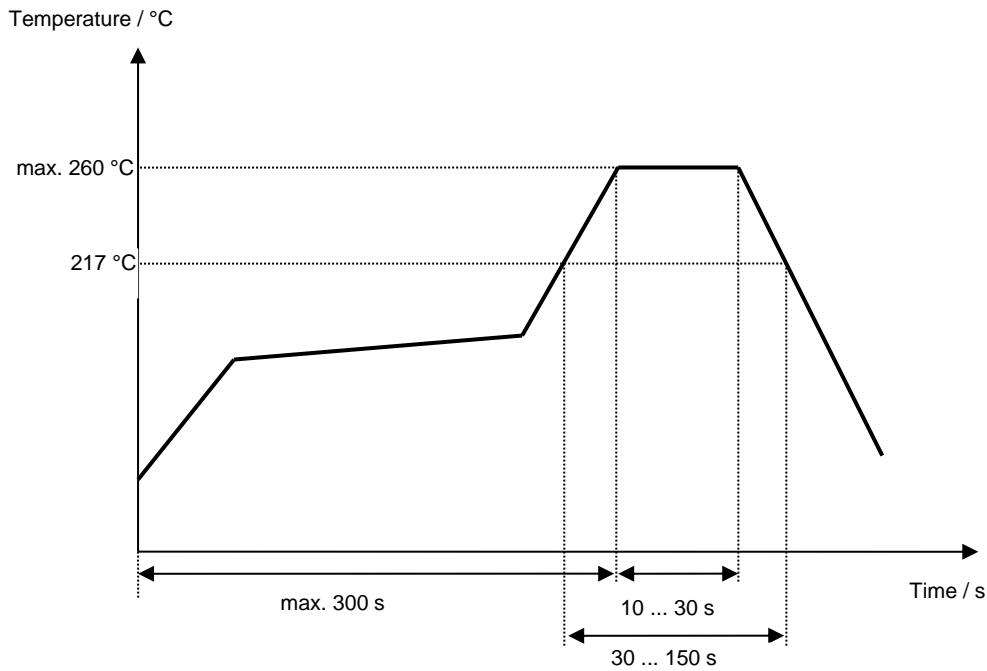

Microchip Frequency Technology GmbH
Potsdamer Straße 18
D 14 513 TELTOW / Germany
Tel: (+49) 3328 4784-0 / Fax: (+49) 3328 4784-30

Microchip Frequency Technology GmbH reserves the right to make changes to the product(s) and/or information contained herein without notice. No liability is assumed as a result of their use or application. No rights under any patent accompany the sale of any such product(s) or information.

Microchip**Filter specification****TFS 90B****5/5****History**

Version	Reason of Changes	Name	Date
1.0	- generation of development specification	Strehl	12.05.2006
1.1	- extend of storage temperature range	Strehl	17.05.2006
1.2	- terminating impedances, typical values, filter characteristics and matching configuration added - frequencies of input signals for intermodulation measurements corrected	Pfeiffer	29.08.2006
1.3	- temperature coefficient of frequency and typical values corrected - change of relative attenuations	Pfeiffer	31.08.2006
1.4	- add plating in construction	Strehl	15.05.2007
1.5	- change stability characteristics	Strehl	11.01.2008
2.0	- change specification data - change tape & reel pull off direction	Bonnen	21.04.2020

Microchip Frequency Technology GmbH
Potsdamer Straße 18
D 14 513 TELTOW / Germany
Tel: (+49) 3328 4784-0 / Fax: (+49) 3328 4784-30

Microchip Frequency Technology GmbH reserves the right to make changes to the product(s) and/or information contained herein without notice. No liability is assumed as a result of their use or application. No rights under any patent accompany the sale of any such product(s) or information.