

SCD4x

Breaking the size barrier in optical CO₂ sensing



Features

- Photoacoustic NDIR sensor technology PASens®
- Small form factor: 10.1 x 10.1 x 6.5 mm³
- Reflow solderable for cost-effective assembly
- Digital I²C interface
- Integrated temperature and humidity sensor

Product Variants

- **SCD40:** Base accuracy, specified measurement range 400 – 2'000 ppm, compatible with WELL Building Standard™¹
- **SCD41:** Improved accuracy, specified measurement range 400 – 5'000 ppm, additionally compatible with California Title 24² and RESET®³, features single-shot operation mode
- **SCD43:** High accuracy, specified measurement range 400 – 5'000 ppm, additionally compatible with ASHRAE Standard 62.1⁴, features single-shot operation mode

Product Summary

The SCD4x is Sensirion's second generation series of optical CO₂ sensors. The sensor series builds on the photoacoustic NDIR sensing principle and Sensirion's patented PASens® and CMOSens® technology to offer high accuracy at an attractive price and small form factor. SMD assembly allows cost- and space-effective integration of the sensor combined with maximal freedom of design. On-chip signal compensation is realized with the built-in SHT4x humidity and temperature sensor.

CO₂ is a key indicator for indoor air quality (IAQ), as high levels compromise human cognitive performance, sleep quality, well-being and can be an indicator for increased airborne disease transmission risk. The SCD4x enables smart ventilation and air conditioning to help improve energy efficiency and human comfort. Moreover, indoor air quality monitors and other connected devices based on the SCD4x can help maintain low CO₂ concentrations for a healthy, productive environment.

Product Overview

Products	Details
SCD40-D-R2	Base accuracy, specified range 400 – 2'000 ppm
SCD41-D-R2	Improved accuracy, specified range 400 – 5'000 ppm, single shot operation feature
SCD43-D-R2	High accuracy, specified range 400 – 5'000 ppm, comprehensive building standard compatibility, single shot operation feature

Functional Block Diagram

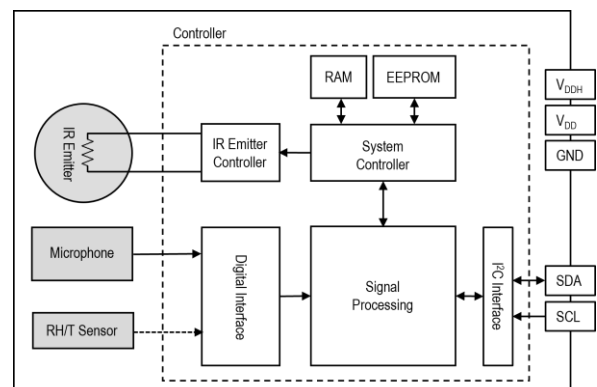

¹ WELL v2, Q4 2024

² 2022 California Building Energy Efficiency Standards for Residential and Nonresidential Buildings

³ RESET Air Standard v2.0 Grade B

⁴ ASHRAE 62.1-2022 incl. Addendum d

Table of Contents

1 Sensor Performance3

 1.1 CO₂ Sensing Performance3

 1.2 Humidity Sensing Performance3

 1.3 Temperature Sensing Performance3

2 Specifications4

 2.1 Electrical Specifications4

 2.2 Absolute Maximum Ratings4

 2.3 Interface Specifications5

 2.4 Timing Specifications6

 2.5 Material Contents6

3 Digital Interface Description7

 3.1 Power-Up and Communication Start7

 3.2 Sensor I²C Address7

 3.3 Data Type & Length7

 3.4 Command Sequence Types7

 3.5 SCD4x Command Overview8

 3.6 Basic Commands9

 3.7 On-Chip Output Signal Compensation10

 3.8 Field Calibration13

 3.9 Low Power Periodic Measurement Mode15

 3.10 Advanced Features16

 3.11 Single Shot Measurement Mode (SCD41 & SCD43 only)19

 3.12 Checksum Calculation23

4 Mechanical Specifications24

 4.1 Package Outline24

 4.2 Land Pattern Recommendation24

 4.3 Tape & Reel Package25

 4.4 Moisture Sensitivity Level25

 4.5 Soldering Instructions26

 4.6 Traceability and Identification26

5 Ordering Information27

 5.1 Historical Information27

6 Revision History28

1 Sensor Performance

1.1 CO₂ Sensing Performance

Default conditions of 25 °C, 50 %RH, ambient pressure of 1013 mbar, continuous operation in periodic measurement mode (see Section 3.6.1) and 3.3 V supply voltage apply to values in the table below, unless otherwise stated.

Parameter	Conditions	Value
CO ₂ output range ⁵	-	0 – 40'000 ppm
SCD40 CO ₂ measurement accuracy ⁶	400 ppm – 2'000 ppm	±(50 ppm + 5% of reading)
SCD41 CO ₂ measurement accuracy ⁶	400 ppm – 1'000 ppm	±(50 ppm + 2.5% of reading)
	1'001 ppm – 2'000 ppm	±(50 ppm + 3% of reading)
	2'001 ppm – 5'000 ppm	±(40 ppm + 5% of reading)
SCD43 CO ₂ measurement accuracy ⁶	400 ppm – 5'000 ppm	±(30 ppm + 3% of reading)
Repeatability	Typical	±10 ppm
Response time ⁷	τ _{63%} , typical, step change 400 – 2'000 ppm	60 s
Additional accuracy drift per year, starting after five years ⁸	Typical, same CO ₂ concentration range as sensor's specified measurement accuracy	±(5 ppm + 0.5 % of reading)

Table 1: SCD4x CO₂ sensor specifications

1.2 Humidity Sensing Performance

SCD4x design-in, self-heating, operation mode and the surrounding environment affects RH/T sensor performance. To achieve the specifications in **Table 2**, the temperature-offset of the SCD4x inside the customer device must be set correctly (see Section 3.7).

Parameter	Conditions	Value
Humidity measurement range	-	0 %RH – 100 %RH
Accuracy (typ.)	15 °C – 35 °C, 20 %RH – 65 %RH	±6 %RH
	-10 °C – 60 °C, 0 %RH – 100 %RH	±9 %RH
Repeatability	Typical	±0.4 %RH
Response time ⁷	τ _{63%} , typical, periodic measurement mode	90 s
Accuracy drift	-	<0.25 %RH / year

Table 2: SCD4x humidity sensor specifications

1.3 Temperature Sensing Performance

SCD4x design-in, self-heating, operation mode and the surrounding environment affects RH/T sensor performance. To achieve the specifications in **Table 3**, the temperature-offset of the SCD4x inside the customer device must be set correctly (see Section 3.7)

Parameter	Conditions	Value
Temperature measurement range	-	- 10 °C – 60 °C
Accuracy (typ.)	15 °C – 35 °C	± 0.8 °C
	-10 °C – 60 °C	± 1.5 °C
Repeatability	-	± 0.1 °C
Response time ⁷	τ _{63%} , typical, periodic measurement mode	120 s
Accuracy drift	-	< 0.03 °C / year

Table 3: SCD4x temperature sensor specifications

⁵ Exposure to CO₂ concentrations smaller than 400 ppm can affect the accuracy of the sensor with ASC enabled.

⁶ Deviation from a high-precision reference with gas mixtures having a ±2% tolerance. Rough handling, shipping, sensor assembly and long-term drift can impact sensor accuracy. Accuracy can be restored by performing forced recalibration (FRC) no less than 5 days after sensor assembly, or maintained by sensor operation with automatic self-calibration (ASC) enabled using default parameters and weekly exposure to air with CO₂ concentrations at 400 ppm. See Section 3.8 for details.

⁷ Response time depends on design-in, signal update rate and environment of the sensor in the final application.

⁸ Deviation is additional to standard accuracy specifications and obtained either after performing FRC or in continuous sensor operation with ASC enabled using default parameters and weekly exposure to air with CO₂ concentrations at 400 ppm. Maximum additional accuracy drift per year starting after five years estimated from stress tests is ±(5 ppm + 2% of reading). Stronger drift may occur if the sensor is not handled according to its handling instructions.

2 Specifications

2.1 Electrical Specifications

Parameter	Symbol	Conditions	Min.	Typical	Max.	Units
Supply voltage DC ⁹	V _{DD}		2.4	3.3 or 5.0	5.5	V
Unloaded supply voltage ripple (peak to peak) ¹⁰	V _{RPP}				30	mV
Peak supply current ¹¹	I _{peak}	V _{DD} = 3.3 V		175	205	mA
		V _{DD} = 5 V		115	137	mA
Average supply current for periodic measurement mode (1 measurement every 5 seconds)	I _{DD}	V _{DD} = 3.3 V		15	18	mA
		V _{DD} = 5 V		11	13	mA
Average supply current for low power periodic measurement mode (1 measurement every 30 seconds)	I _{DD}	V _{DD} = 3.3 V		3.2	3.5	mA
		V _{DD} = 5 V		2.8	3	mA
Average supply current for single shot mode, 1 measurement every 5 minutes (SCD41/SCD43) ¹²	I _{DD}	V _{DD} = 3.3 V		0.45	0.5	mA
		V _{DD} = 5 V		0.36	0.4	mA
Input high level voltage	V _{IH}		0.65 x V _{DD}		1 x V _{DD}	-
Input low level voltage	V _{IL}				0.3 x V _{DD}	-
Output low level voltage	V _{OL}	3 mA sink current			0.66	V

Table 4: SCD4x electrical specifications

2.2 Absolute Maximum Ratings

Stress levels beyond those listed in **Table 5** may cause permanent damage to the device. Exposure to minimum/maximum rating conditions for extended periods may affect sensor performance and device reliability.

Parameter	Conditions	Value
Temperature operating conditions		-10 – 60 °C
Humidity operating conditions ¹³	Non-condensing	0 – 95 %RH
MSL Level		1
DC supply voltage		-0.3 V – 6.0 V
Max. voltage on pins SDA, SCL, GND		-0.3 V – V _{DD} + 0.3 V
Input current on pins SDA, SCL, GND		-280 mA – 100 mA
Short term storage temperature ¹⁴		-40 °C – 70 °C
Recommended storage temperature		10 °C – 50 °C
ESD HBM (pads and metal cap)		2 kV
ESD CDM		500 V
Maintenance interval	Maintenance free when the ASC algorithm ¹⁵ is used.	None
Sensor lifetime ¹⁶	Typical operating conditions	>10 years

Table 5: SCD4x operation conditions, lifetime and maximum ratings

⁹ Supply voltage must be kept constant for stable sensor operation.

¹⁰ Determined on the supply voltage without the load of the sensor.

¹¹ Refers to sustained current.

¹² On-demand measurement with adjustable interval. See Section 3.11 for details.

¹³ Accuracy can be reduced at relative humidity levels lower than 10%.

¹⁴ Short term storage refers to temporary conditions e.g., during transport.

¹⁵ For proper function of the ASC field-calibration algorithm with default parameters, SCD4x must be exposed to air with CO₂ concentrations at 400 ppm on a weekly basis.

¹⁶ Sensor tested over simulated lifetime of >10 years for an indoor environment mission profile.

2.3 Interface Specifications

The SCD4x comes in an LGA package (**Table 6**). Further details on the sensor's package can be found in Section 4.1. A recommended land pattern for SCD4x can be found in Section 4.2.

Name	Comments
VDD	Supply voltage
VDDH	Supply voltage IR source, must be connected to VDD on customer PCB
GND	Ground contact
SDA	I ² C serial data, bidirectional
SCL	I ² C serial clock
DNC	Do not connect, pads must be soldered to a floating pad on the customer PCB

Table 6: Pin assignment (top view). The notched corner of the protection membrane serves as a polarity mark to indicate pin 1 location.

VDD and VDDH are used to supply the sensor and must always be kept at the same voltage, i.e. both should be connected to the same power supply. The combined maximum current drawn on VDD and VDDH is indicated in **Table 4**. VDD and VDDH must be connected to each other close to the sensor on the customer PCB.

For sensor operation, a low noise power supply, such as a low-dropout regulator (LDO), which can handle the peak supply current as specified in **Table 4** must be chosen. Due to the sensor's internal regulation, higher transient currents (on the timescale of microseconds) may be observed. These transient currents can be neglected in typical design-in scenarios due to the parasitic R/L/C of the leads as well as the load regulation characteristics of the supply. Additionally, to avoid interference with the sensor regulation, the supply voltage without the load of the sensor must not vary by more than 30 mV (e.g. ripples or drops caused by other loads). Operating the sensor with a separate LDO is recommended.

SCD4x uses I²C communication based on NXP's I²C-bus specification and user manual¹⁷. I²C standard and fast mode operation are supported. SCL is used to synchronize the I²C communication between the master (microcontroller) and the slave (sensor). The SDA pin is used to transfer data to and from the sensor. For safe communication, the timing specifications defined in the I²C manual¹⁷ and Section 2.4 must be met. Both SCL and SDA lines should be connected to external pull-up resistors (e.g. R_p = 10 kΩ, see **Figure 1**). To avoid signal contention, the microcontroller must only drive SDA and SCL low. For dimensioning resistor sizes, please take bus capacity and communication frequency into account (see example in Section 7.1 of NXP's I²C Manual for more details¹⁷). Note that pull-up resistors may be included in the I/O circuits of microcontrollers.

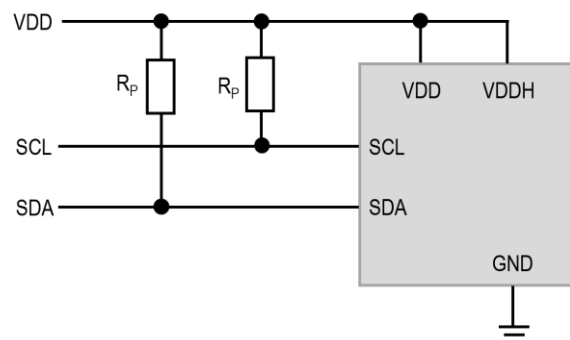

Figure 1: Typical application circuit (representative and not to scale).

¹⁷ NXP I²C-bus specification and user manual UM10204, Rev.6, 4 April 2014

2.4 Timing Specifications

Table 7 lists the timings of the SCD4x¹⁸.

Parameter	Condition	Min.	Max.	Unit
Power-up time	After hard reset, $V_{DD} \geq 2.25\text{ V}$	-	30	ms
Soft reset time	After re-initialization (i.e. reinit)	-	30	ms
SCL clock frequency	-	0	400	kHz

Table 7: System timing specifications.

2.5 Material Contents

The device is fully REACH and RoHS compliant.

¹⁸ Timing specifications based on the NXP I2C-bus specification and user manual UM10204, Rev.6, 4 April 2014

3 Digital Interface Description

3.1 Power-Up and Communication Start

The sensor starts powering-up after reaching the power-up threshold voltage $V_{DD,min}$ and will take up to the maximum of the power-up time to enter the idle state. Once the idle state has been reached, it is ready to receive commands from the master. Each transmission sequence begins with a START condition (S) and ends with a STOP condition (P) as described in the I²C-bus specification.

3.2 Sensor I²C Address

SCD4x can be addressed by sending its 7-bit I²C address, given in **Table 8**, followed by an eighth bit denoting the communication direction: a “zero” indicates a “write” request, a “one” a “read” request.

SCD4x	Hex. Code
I ² C address	0x62

Table 8: I²C device address

3.3 Data Type & Length

Data sent to and received from the sensor consists of a sequence of 16-bit commands and/or 16-bit words (each to be interpreted as unsigned integer with the most significant byte transmitted first). Each data word is immediately succeeded by an 8-bit CRC. In write direction it is mandatory to transmit the checksum. In read direction it is up to the master to decide if it wants to process the checksum (see Section 3.12).

3.4 Command Sequence Types

The SCD4x features four different I²C command sequence types: “read I²C sequences”, “write I²C sequences”, “send I²C command” and “send command and fetch result” sequences. **Figure 2** illustrates how the I²C communication for the different sequence types is built-up.

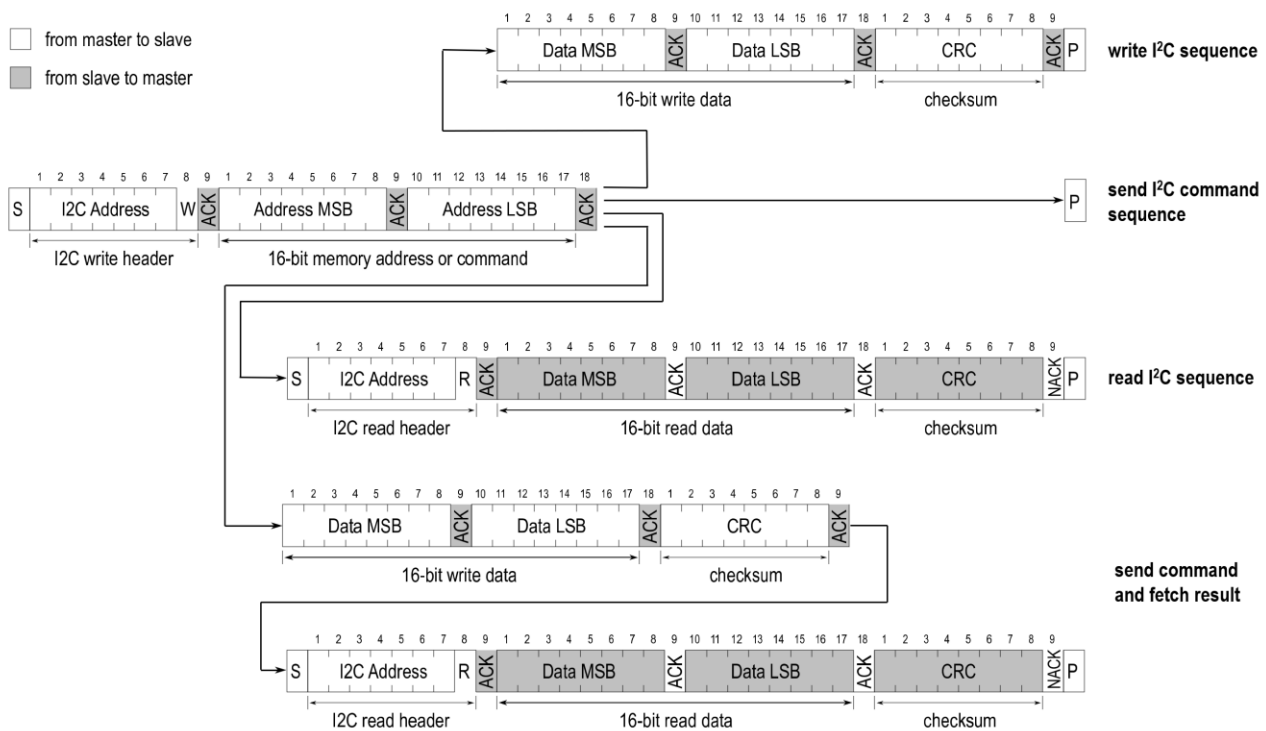

Figure 2: Command sequence types: “write”, “send command”, “read”, and “send command and fetch result”

For the “read” or “send command and fetch results” sequences, after writing the address and/or data to the sensor and receiving the ACK bit from the sensor, it is required to wait for the command *execution time* (see **Table 9**) before issuing the read header. If a command execution time is specified in **Table 9**, further commands must not be sent during that command’s *execution time*.

3.5 SCD4x Command Overview

An overview of the available SCD4x commands can be found in **Table 9**. A detailed description for each command can be found in the following sections. Note that some commands may also be executed while a periodic measurement mode is running.

Domain	Command	Hex. Code	I ² C sequence type (see Section 3.4)	Execution	
				time [ms]	During meas.
Basic commands Section 3.6	start_periodic_measurement	0x21b1	send command	-	no
	read_measurement	0xec05	read	1	yes
	stop_periodic_measurement	0x3f86	send command	500	yes
On-chip output signal compensation Section 3.7	set_temperature_offset	0x241d	write	1	no
	get_temperature_offset	0x2318	read	1	no
	set_sensor_altitude	0x2427	write	1	no
	get_sensor_altitude	0x2322	read	1	no
	set_ambient_pressure	0xe000	write	1	yes
	get_ambient_pressure	0xe000	read	1	yes
Field calibration Section 3.8	perform_forced_recalibration	0x362f	send command and fetch result	400	no
	set_automatic_self_calibration_enabled	0x2416	write	1	no
	get_automatic_self_calibration_enabled	0x2313	read	1	no
	set_automatic_self_calibration_target	0x243a	write	1	no
	get_automatic_self_calibration_target	0x233f	read	1	no
Low power periodic measurement mode Section 3.9	start_low_power_periodic_measurement	0x21ac	send command	-	no
	get_data_ready_status	0xe4b8	read	1	yes
Advanced features Section 3.10	persist_settings	0x3615	send command	800	no
	get_serial_number	0x3682	read	1	no
	perform_self_test	0x3639	read	10'000	no
	perform_factory_reset	0x3632	send command	1'200	no
	reinit	0x3646	send command	30	no
	get_sensor_variant	0x202f	read	1	no
Single shot measurement mode (SCD41 & SCD43) Section 3.11	measure_single_shot	0x219d	send command	5'000	no
	measure_single_shot_rht_only	0x2196	send command	50	no
	power_down	0x36e0	send command	1	no
	wake_up	0x36f6	send command	30	no
	set_automatic_self_calibration_initial_period	0x2445	write	1	no
	get_automatic_self_calibration_initial_period	0x2340	read	1	no
	set_automatic_self_calibration_standard_period	0x244e	write	1	no
	get_automatic_self_calibration_standard_period	0x234b	read	1	no

Table 9: List of SCD4x sensor commands. The rightmost column ("During meas.") indicates whether the command can be executed while a periodic measurement mode is running.

3.6 Basic Commands

This section lists the basic SCD4x commands that are necessary to start the periodic measurement mode and subsequently read out the sensor outputs.

The typical communication sequence between the I²C master (e.g., a microcontroller) and the SCD4x sensor is as follows:

1. The sensor is powered up into the idle state.
2. The I²C master sends a *start_periodic_measurement* command. The signal update interval is 5 seconds.
3. The I²C master periodically reads out data with the *read_measurement* command.
4. When the sensor is to stop taking measurements periodically, the I²C master sends the *stop_periodic_measurement* command to return the sensor to idle mode.

While the periodic measurement mode is running, no other commands may be issued, with exception of *read_measurement*, *get_data_ready_status*, *stop_periodic_measurement*, *set_ambient_pressure* and *get_ambient_pressure*.

3.6.1 start_periodic_measurement

Description: starts the periodic measurement mode. The signal update interval is 5 seconds.

Write (hexadecimal)	Input parameter: -		Response parameter: -		Max. command duration [ms]
	length [bytes]	signal conversion	length [bytes]	signal conversion	
0x21b1	-	-	-	-	not applicable
Example: start periodic measurement					
Write (hexadecimal)	0x21b1 Command				

Table 10: start_periodic_measurement I²C sequence description

3.6.2 read_measurement

Description: reads the sensor output. The measurement data can only be read out once per signal update interval as the buffer is emptied upon read-out. If no data is available in the buffer, the sensor returns a NACK. To avoid a NACK response, the *get_data_ready_status* can be issued to check data status (see Section 3.9.2 for further details). The I²C master can abort the read transfer with a NACK followed by a STOP condition after any data byte if the user is not interested in subsequent data.

Write (hexadecimal)	Input parameter: -		Response parameter: CO ₂ , Temperature, Relative Humidity		Max. command duration [ms]	
	length [bytes]	signal conversion	length [bytes]	signal conversion		
0xec05	-	-	3	$CO_2 \text{ [ppm]} = \text{word}[0]$	1	
			3	$T = -45 + 175 * \frac{\text{word}[1]}{2^{16} - 1}$		
			3	$RH = 100 * \frac{\text{word}[2]}{2^{16} - 1}$		
Example: read sensor output (500 ppm, 25 °C, 37 %RH)						
Write (hexadecimal)	0xec05 Command					
Wait	1 ms	command execution time				
Response (hexadecimal)	0x01f4 CO ₂ = 500 ppm	0x33 CRC of 0x01f4	0x6667 Temp. = 25 °C	0xa2 CRC of 0x6667	0x5eb9 RH = 37%	0x3c CRC of 0x5eb9

Table 11: read_measurement I²C sequence description

3.6.3 stop_periodic_measurement

Description: Command returns a sensor running in periodic measurement mode or low power periodic measurement mode back to the idle state, e.g. to then allow changing the sensor configuration or to save power. Note that the sensor will only respond to other commands 500 ms after the *stop_periodic_measurement* command has been issued.

Write (hexadecimal)	Input parameter: -		Response parameter: -		Max. command duration [ms]
	length [bytes]	signal conversion	length [bytes]	signal conversion	
0x3f86	-	-	-	-	500
Example: stop periodic measurement					
Write (hexadecimal)	0x3f86 Command				

Table 12: stop_periodic_measurement I²C sequence description

3.7 On-Chip Output Signal Compensation

The SCD4x features on-chip signal compensation to automatically counteract temperature and humidity effects on CO₂ measurements. Additionally, it is possible to provide the sensor with externally obtained pressure or altitude values to enable on-board compensation of the CO₂ output signal for pressure variations. Furthermore, it is possible to improve the accuracy of the relative humidity and temperature output signal by adjusting the temperature offset parameter for the design-in of the sensor. Note that the temperature offset does not impact the accuracy of the CO₂ output.

To change or read sensor settings, the SCD4x must be in the idle state (exception: ambient pressure parameters). A typical sequence between the I²C master and the SCD4x is described as follows:

1. If the sensor is operated in a periodic measurement mode, the I²C master sends a *stop_periodic_measurement* command.
2. The I²C master sends one or several commands to get or set sensor settings / parameters.
3. If changes shall be retained across power-cycles, the *persist_settings* command must be sent (see Section 3.10.1)
4. The I²C master sends a *start_periodic_measurement* command to set the sensor in the operating mode again.

3.7.1 set_temperature_offset

Description: Setting the temperature offset of the SCD4x inside the customer device allows the user to optimize the RH and T output signal. The temperature offset can depend on several factors such as the SCD4x measurement mode, self-heating of close components, the ambient temperature and air flow. Thus, the SCD4x temperature offset should be determined after integration into the final device and under its typical operating conditions (including the operation mode to be used in the application) in thermal equilibrium. By default, the temperature offset is set to 4 °C. To save the setting to the EEPROM, the *persist_settings* (see Section 3.10.1) command may be issued. Equation (1) details how the characteristic temperature offset can be calculated using the current temperature output of the sensor (T_{SCD4x}), a reference temperature value ($T_{Reference}$), and the previous temperature offset ($T_{Offset_previous}$) obtained using the *get_temperature_offset* command (Section 3.7.2). Recommended temperature offset values are between 0 °C and 20 °C.

$$T_{Offset_actual} = T_{SCD4x} - T_{Reference} + T_{Offset_previous} \tag{1}$$

Write (hexadecimal)	Input parameter: Offset temperature		Response parameter: -		Max. command duration [ms]
	length [bytes]	signal conversion	length [bytes]	signal conversion	
0x241d	3	$word[0] = T_{Offset} [^{\circ}C] * \frac{2^{16}-1}{175}$	-	-	1
Example: set temperature offset to 5.4 °C					
Write (hexadecimal)	0x241d Command	0x07e6 $T_{offset} = 5.4 \text{ } ^{\circ}C$	0x48 CRC of 0x7e6		

Table 13: set_temperature_offset I²C sequence description

3.7.2 get_temperature_offset

Write (hexadecimal)	Input parameter: -		Response parameter: Offset temperature		Max. command duration [ms]
	length [bytes]	signal conversion	length [bytes]	signal conversion	
0x2318	-	-	3	$T_{offset} [^{\circ}C] = word[0] * \frac{175}{2^{16}-1}$	1
Example: temperature offset is 6.2 °C					
Write (hexadecimal)	0x2318 Command				
Wait	1 ms	command execution time			
Response (hexadecimal)	0x0912 $T_{offset} = 6.2\text{ }^{\circ}C$	0x63 CRC of 0x0912			

Table 14: get_temperature_offset I²C sequence description

3.7.3 set_sensor_altitude

Description: Reading and writing the sensor altitude must be done while the SCD4x is in idle mode. Typically, the sensor altitude is set once after device installation. To save the setting to the EEPROM, the *persist_settings* (see Section 3.10.1) command must be issued. The default sensor altitude value is set to 0 meters above sea level. Valid input values are between 0 – 3'000 m.

Write (hexadecimal)	Input parameter: Sensor altitude		Response parameter: -		Max. command duration [ms]
	length [bytes]	signal conversion	length [bytes]	signal conversion	
0x2427	3	word[0] = Sensor altitude [m]	-	-	1
Example: set sensor altitude to 1'950 m					
Write (hexadecimal)	0x2427 Command	0x079e Sensor altitude = 1'950 m	0x09 CRC of 0x079e		

Table 15: set_sensor_altitude I²C sequence description

3.7.4 get_sensor_altitude

Description: The *get_sensor_altitude* command can be sent while the SCD4x is in idle mode to read out the previously saved sensor altitude value set by the *set_sensor_altitude* command.

Write (hexadecimal)	Input parameter: -		Response parameter: Sensor altitude		Max. command duration [ms]
	length [bytes]	signal conversion	length [bytes]	signal conversion	
0x2322	-	-	3	Sensor altitude [m] = word[0]	1
Example: sensor altitude is 1'100 m					
Write (hexadecimal)	0x2322 Command				
Wait	1 ms	command execution time			
Response (hexadecimal)	0x044c Sensor altitude = 1'100 m	0x42 CRC of 0x044c			

Table 16: get_sensor_altitude I²C sequence description

3.7.5 set_ambient_pressure

Description: The *set_ambient_pressure* command can be sent during periodic measurements to enable continuous pressure compensation. Note that setting an ambient pressure overrides any pressure compensation based on a previously set sensor altitude. Use of this command is highly recommended for applications experiencing significant ambient pressure changes to ensure sensor accuracy. Valid input values are between 70'000 – 120'000 Pa. The default value is 101'300 Pa. The read/write bit that is part of the I²C header is used to differentiate between the *get_ambient_pressure* and *set_ambient_pressure* commands

Write (hexadecimal)	Input parameter: Ambient pressure		Response parameter: -		Max. command duration [ms]
	length [bytes]	signal conversion	length [bytes]	signal conversion	
0xe000	3	word[0] = ambient P [Pa] / 100	-	-	1
Example: set ambient pressure to 98'700 Pa					
Write (hexadecimal)	0xe000 Command	0x03db Ambient P = 98'700 Pa	0x42 CRC of 0x03db		

Table 17: set_ambient_pressure I²C sequence description

3.7.6 get_ambient_pressure

Description: The *get_ambient_pressure* command can be sent during periodic measurements to read out the previously saved ambient pressure value set by the *set_ambient_pressure* command. The read/write bit that is part of the I²C header is used to differentiate between the *get_ambient_pressure* and *set_ambient_pressure* commands.

Write (hexadecimal)	Input parameter: -		Response parameter: Ambient pressure		Max. command duration [ms]
	length [bytes]	signal conversion	length [bytes]	signal conversion	
0xe000	-	-	3	ambient P [Pa] = word[0] * 100	1
Example: ambient pressure is 98'700 Pa					
Write (hexadecimal)	0xe000 Command				
Wait	1 ms	command execution time			
Response (hexadecimal)	0x03db Ambient P = 98'700 Pa	0x42 CRC of 0x03db			

Table 18: get_ambient_pressure I²C sequence description

3.8 Field Calibration

To achieve high initial and excellent long-term accuracy, the SCD4x includes two field calibration features: Forced recalibration (FRC) and automatic self-calibration (ASC).

The ASC enables excellent long-term stability of SCD4x without the need for regular user intervention. The algorithm leverages the sensor's measurement history and the assumption that the sensor is exposed to a known minimum background CO₂ concentration at least once during a period of time accumulated while taking measurements. By default, the ASC algorithm assumes that the sensor, while taking measurements, was exposed to outdoor fresh air at 400 ppm CO₂ concentration at least once for >3 minutes after every week of operation accumulated by using one of the following measurement modes for at least 4 hours at a time: periodic measurement mode (Section 3.6), low power periodic measurement mode (Section 3.9) or single shot mode with a measurement interval of 5 minutes (SCD41 and SCD43 only, see Section 3.11).

Performing FRC restores high accuracy by providing the SCD4x with an externally obtained CO₂ reference value. FRC can be applied to quickly correct the sensor's output, e.g. if it is not possible to wait for and/or rely on ASC.

3.8.1 perform_forced_recalibration

Description: To successfully conduct an accurate FRC, the following steps need to be carried out:

1. Operate the SCD4x in the operation mode later used for normal sensor operation (e.g. periodic measurement) for at least 3 minutes (single-shot mode: for > 3 single-shots at 1-minute measurement interval) in an environment with homogenous and constant CO₂ concentration. The sensor must be operated at the voltage desired for the application when performing the FRC sequence. If applicable, the reference value for altitude or pressure compensation must be provided to the sensor beforehand.
2. Issue the *stop_periodic_measurement* command. Wait 500 ms for the command to complete.
3. Issue the *perform_forced_recalibration* command and optionally read out the FRC correction (i.e. the magnitude of the correction) after waiting for 400 ms for the command to complete. A return value of 0xffff indicates that the FRC has failed because the sensor was not operated before sending the command.

Write (hexadecimal)	Input parameter: Target CO ₂ concentration		Response parameter: FRC-correction		Max. command duration [ms]
	length [bytes]	signal conversion	length [bytes]	signal conversion	
0x362f	3	word[0] = Target concentration [ppm CO ₂]	3	FRC correction [ppm CO ₂] = word[0] – 0x8000 word[0] = 0xffff in case of failed FRC	400
Example: perform forced recalibration, providing a reference CO ₂ concentration of 480 ppm to a SCD4x sensor outputting 530 ppm.					
Write (hexadecimal)	0x362f <i>Command</i>	0x01e0 <i>Input: 480 ppm</i>	0xb4 <i>CRC of 0x01e0</i>		
Wait	400 ms	<i>command execution time</i>			
Response (hexadecimal)	0x7fce <i>Response: - 50 ppm</i>	0x7b <i>CRC of 0x7fce</i>			

Table 19: perform_forced_recalibration I²C sequence description

3.8.2 set_automatic_self_calibration_enabled

Description: sets the current state (enabled / disabled) of the ASC. By default, ASC is enabled. To save the setting to the EEPROM, the *persist_settings* (see Section 3.10.1) command must be issued.

Write (hexadecimal)	Input parameter: ASC enabled		Response parameter: -		Max. command duration [ms]
	length [bytes]	signal conversion	length [bytes]	signal conversion	
0x2416	3	word[0] = 1 → ASC enabled word[0] = 0 → ASC disabled	-	-	1
Example: set ASC status: enabled					
Write (hexadecimal)	0x2416 Command	0x0001 ASC enabled	0xb0 CRC of 0x0001		

Table 20: set_automatic_self_calibration_enabled I²C sequence description.

3.8.3 get_automatic_self_calibration_enabled

Write (hexadecimal)	Input parameter: -		Response parameter: ASC enabled		Max. command duration [ms]
	length [bytes]	signal conversion	length [bytes]	signal conversion	
0x2313	-	-	3	word[0] = 1 → ASC enabled word[0] = 0 → ASC disabled	1
Example: read ASC status: disabled					
Write (hexadecimal)	0x2313 Command				
Wait	1 ms	command execution time			
Response (hexadecimal)	0x0000 ASC disabled	0x81 CRC of 0x0000			

Table 21: get_automatic_self_calibration_enabled I²C sequence description

3.8.4 set_automatic_self_calibration_target

Description: sets the value of the ASC baseline target, i.e. the CO₂ concentration in ppm which the ASC algorithm will assume as lower-bound background to which the SCD4x is exposed to regularly within one ASC period of operation. To save the setting to the EEPROM, the *persist_settings* (see Section 3.10.1) command must be issued subsequently.

Write (hexadecimal)	Input parameter: -		Response parameter:		Max. command duration [ms]
	length [bytes]	signal conversion	length [bytes]	signal conversion	
0x243a	3	word[0] = ASC target [ppm CO ₂]	-	-	1
Example: Set ASC target to 435 ppm					
Write (hexadecimal)	0x243a Command	0x01b3 ASC target = 435 ppm	0x99 CRC of 0x01b3		

Table 22: set_automatic_self_calibration_target I²C sequence description

3.8.5 get_automatic_self_calibration_target

Description: reads out the ASC baseline target concentration parameter. The factory default value is 400 ppm.

Write (hexadecimal)	Input parameter: -		Response parameter: ASC baseline target		Max. command duration [ms]
	length [bytes]	signal conversion	length [bytes]	signal conversion	
0x233f	-	-	3	word[0] = ASC target [ppm CO ₂]	1
Example: ASC target is 420 ppm					
Write (hexadecimal)	0x233f <i>Command</i>				
Wait	1 ms <i>command execution time</i>				
Response (hexadecimal)	0x01a4 <i>ASC target is 420 ppm</i>		0x4d <i>CRC of 0x01a4</i>		

Table 23: get_automatic_self_calibration_target I²C sequence description

3.9 Low Power Periodic Measurement Mode

To enable use-cases with a constrained power budget, the SCD4x features a low power periodic measurement mode with a signal update interval of approximately 30 seconds. The low power periodic measurement mode is initiated using the *start_low_power_periodic_measurement* command and read-out in a similar manner as the periodic measurement mode using the *read_measurement* command. Please consult Section 3.6.2 for further instructions.

To periodically check whether a new measurement result is available for read out, the *get_data_ready_status* command (Section 3.9.2) can be used to synchronize to the sensor’s internal measurement interval as an alternative to relying on the ACK/NACK status of the *read_measurement_command* (Section 3.6.2)

3.9.1 start_low_power_periodic_measurement

Description: starts the low power periodic measurement mode. The signal update interval is approximately 30 seconds.

Write (hexadecimal)	Input parameter: -		Response parameter: -		Max. command duration [ms]
	length [bytes]	signal conversion	length [bytes]	signal conversion	
0x21ac	-	-	-	-	not applicable
Example: start low power periodic measurement					
Write (hexadecimal)	0x21ac <i>Command</i>				

Table 24: start_low_power_periodic_measurement I²C sequence description

3.9.2 get_data_ready_status

Description: polls the sensor for whether data from a periodic or single shot measurement is ready to be read out.

Write (hexadecimal)	Input parameter: -		Response parameter: data ready status		Max. command duration [ms]
	length [bytes]	signal conversion	length [bytes]	signal conversion	
0xe4b8	-	-	3	If the least significant 11 bits of word[0] are: 0 → data not ready else → data ready for read-out	1
Example: read data ready status: data not ready					
Write (hexadecimal)	0xe4b8 Command				
Wait	1 ms	command execution time			
Response (hexadecimal)	0x8000	0xa2		Least significant 11 bits are 0 → data not ready CRC of 0x8000	

Table 25: get_data_ready_status I²C sequence description

3.10 Advanced Features

3.10.1 persist_settings

Description: Configuration settings such as the temperature offset, sensor altitude and the ASC enabled/disabled parameters are by default stored in the volatile memory (RAM) only. The *persist_settings* command stores the current configuration in the EEPROM of the SCD4x, ensuring the current settings persist after power-cycling. To avoid unnecessary wear of the EEPROM, the *persist_settings* command should only be sent following configuration changes whose persistence is required. The EEPROM is guaranteed to withstand at least 2000 write cycles. Note that field calibration history (i.e. FRC and ASC, see Section 3.8) is automatically stored in a separate EEPROM dimensioned for the specified sensor lifetime when operated continuously in either periodic measurement mode (see Section 3.5.1), low power periodic measurement mode (see Section 3.9) or single shot mode with 5 minute measurement interval (SCD41 and SCD43 only, see Section 3.11).

Write (hexadecimal)	Input parameter: -		Response parameter: -		Max. command duration [ms]
	length [bytes]	signal conversion	length [bytes]	signal conversion	
0x3615	-	-	-	-	800
Example: persist settings					
Write (hexadecimal)	0x3615 Command				

Table 26: persist_settings I²C sequence description

3.10.2 get_serial_number

Description: Reading out the serial number can be used to identify the chip and to verify the presence of the sensor. The *get_serial_number* command returns 3 words, and every word is followed by an 8-bit CRC checksum. Together, the 3 words constitute a unique serial number with a length of 48 bits (in big endian format).

Write (hexadecimal)	Input parameter: -		Response parameter: serial number			Max. command duration [ms]
	length [bytes]	signal conversion	length [bytes]	signal conversion		
0x3682	-	-	9	Serial number = word[0] << 32 word[1] << 16 word[2]		1
Example: serial number is 273'325'796'834'238						
Write (hexadecimal)	0x3682 Command					
Wait	1 ms <i>command execution time</i>					
Response (hexadecimal)	0xf896 word[0]	0x31 CRC of 0xf896	0x9f07 word[1]	0xc2 CRC of 0x9f07	0x3bbe word[2]	0x89 CRC of 0x3bbe

Table 27: get_serial_number I²C sequence description

3.10.3 perform_self_test

Description: The *perform_self_test* command can be used as an end-of-line test to check the sensor functionality.

Write (hexadecimal)	Input parameter: -		Response parameter: sensor status		Max. command duration [ms]
	length [bytes]	signal conversion	length [bytes]	signal conversion	
0x3639	-	-	3	word[0] = 0 → no malfunction detected word[0] ≠ 0 → malfunction detected	10'000
Example: perform self-test, no malfunction detected					
Write (hexadecimal)	0x3639 Command				
Wait	10000 ms <i>command execution time</i>				
Response (hexadecimal)	0x0000 No malfunction detected		0x81 CRC of 0x0000		

Table 28: perform_self_test I²C sequence description

3.10.4 perform_factory_reset

Description: The *perform_factory_reset* command resets all configuration settings stored in the EEPROM and erases the FRC and ASC algorithm history.

Write (hexadecimal)	Input parameter: -		Response parameter: -		Max. command duration [ms]
	length [bytes]	signal conversion	length [bytes]	signal conversion	
0x3632	-	-	-	-	1'200
Example: perform factory reset					
Write (hexadecimal)	0x3632 Command				

Table 29: perform_factory_reset I²C sequence description

3.10.5 **reinit**

Description: The *reinit* command reinitializes the sensor by reloading user settings from EEPROM. The sensor must be in the idle state before sending the *reinit* command. If the *reinit* command does not trigger the desired re-initialization, a power-cycle should be applied to the SCD4x.

Write (hexadecimal)	Input parameter: -		Response parameter: -		Max. command duration [ms]
	length [bytes]	signal conversion	length [bytes]	signal conversion	
0x3646	-	-	-	-	30
Example: reinit					
Write (hexadecimal)	0x3646 Command				

Table 30: reinit I²C sequence description

3.10.6 **get_sensor_variant**

Description: reads out the SCD4x sensor variant (e.g. SCD40, SCD41 or SCD43).

Write (hexadecimal)	Input parameter: -		Response parameter: sensor variant		Max. command duration [ms]
	length [bytes]	signal conversion	length [bytes]	signal conversion	
0x202f	-	-	3	Word[0]: Bits[15...12] = 0000 → SCD40 Bits[15...12] = 0001 → SCD41 Bits[15...12] = 0101 → SCD43	1
Write (hexadecimal)	0x202f Command				
Wait	1 ms		<i>command execution time</i>		
Example: sensor variant is SCD41. Response bits 0...11 may differ from this example					
Response (hexadecimal)	0x1440	0x51	<i>Product version = SCD41 CRC of 0x1440</i>		
Example: sensor variant is SCD40. Response bits 0...11 may differ from this example					
Response (hexadecimal)	0x0440	0x3F	<i>Product version = SCD40 CRC of 0x0440</i>		
Example: sensor variant is SCD43. Response bits 0...11 may differ from this example					
Response (hexadecimal)	0x5441	0xE9	<i>Product version = SCD43 CRC of 0x5441</i>		

Table 31: get_sensor_variant I²C sequence description

3.11 Single Shot Measurement Mode (SCD41 & SCD43 only)

The SCD41 and SCD43 additionally feature a single shot measurement mode for on-demand measurements. The typical communication sequence is as follows:

1. The sensor is powered up with the *wake_up* command if previously powered down using the *power_down* command.
2. The I²C master sends a *measure_single_shot* command and waits for the indicated *max. command duration* time.
3. The I²C master reads out data with the *read_measurement* command (3.6.2) after the specified *max. command duration* time.
4. Repeat steps 2–3 as required by the application.
5. If desired, power down the sensor with the *power_down* command.

To reduce noise levels, the I²C master can perform several single shot measurements in a row and average the CO₂ output values. Note: The fastest possible sampling interval for single shot measurements is 5 seconds.

The ASC is enabled by default in single shot operation and optimized for single shot measurements performed every 5 minutes. Longer or shorter single shot measurement intervals will result in less or more frequent ASC corrections, respectively. To adapt the ASC parameters for measurement intervals other than 5 minutes, the ASC initial and standard period length parameters can be adjusted (see relevant commands in following subsections and relevant supporting documentation¹⁹). The standard period represents the cumulative duration of the sensor in measurement mode, tracked in blocks of 4 hours, periodically triggering automatic self-calibration. If operated for the very first time, or following a *perform_factory_reset* command, the shorter initial period parameter is used exactly and only once.

Note that, for single shot operation with ASC enabled and measurement intervals of less than 5 minutes, the lifetime of EEPROM used by the ASC is reduced proportionally.

To further reduce the sensor’s power consumption, the sensor may be power cycled between measurements either by cutting/re-applying the supply and I²C voltages or by using the *power_down/wake_up* commands. Note that for power-cycled single shot operation, ASC functionality is not available in either case.

3.11.1 *measure_single_shot*

Description: on-demand measurement of CO₂ concentration, relative humidity and temperature. The sensor output is read out by using the *read_measurement* command (Section 3.6.2).

Write (hexadecimal)	Input parameter: -		Response parameter: -		Max. command duration [ms]
	length [bytes]	signal conversion	length [bytes]	signal conversion	
0x219d	-	-	-	-	5'000
Example: measure single shot					
Write (hexadecimal)	0x219d Command				

Table 32: *measure_single_shot* I²C sequence description

¹⁹ More information on ASC settings and SCD4x low power modes can be found in the application note on “Low Power Operation SCD4x”

3.11.2 measure_single_shot_rht_only

Description: on-demand measurement of relative humidity and temperature only, significantly reduces power consumption. The sensor output is read out by using the *read_measurement* command (Section 3.6.2). CO₂ output is returned as 0 ppm.

Write (hexadecimal)	Input parameter: -		Response parameter: -		Max. command duration [ms]
	length [bytes]	signal conversion	length [bytes]	signal conversion	
0x2196	-	-	-	-	50
<p>Example: measure single shot, RH and T output only</p> <p>Write 0x2196 (hexadecimal) Command</p>					

Table 33: measure_single_shot_rht_only I²C sequence description

3.11.3 power_down

Description: put the sensor from idle to sleep to reduce current consumption. Can be used to power down when operating the sensor in power-cycled single shot mode.

Write (hexadecimal)	Input parameter: -		Response parameter: -		Max. command duration [ms]
	length [bytes]	signal conversion	length [bytes]	signal conversion	
0x36e0	-	-	-	-	1
<p>Example: power down the sensor</p> <p>Write 0x36e0 (hexadecimal) Command</p>					

Table 34: power_down I²C sequence description

3.11.4 wake_up

Description: wake up the sensor from sleep mode into idle mode. Note that the SCD4x does not acknowledge the *wake_up* command. The sensor's idle state after wake up can be verified by reading out the serial number (Section 3.10.2).

Write (hexadecimal)	Input parameter: -		Response parameter: -		Max. command duration [ms]
	length [bytes]	signal conversion	length [bytes]	signal conversion	
0x36f6	-	-	-	-	30
<p>Example: wake up the sensor</p> <p>Write 0x36f6 (hexadecimal) Command</p>					

Table 35: wake_up I²C sequence description

3.11.5 set_automatic_self_calibration_initial_period

Description: sets the duration of the initial period for ASC correction (in hours). By default, the initial period for ASC correction is 44 hours. Allowed values are integer multiples of 4 hours. A value of 0 results in an immediate correction. To save the setting to the EEPROM, the *persist_settings* (see Section 3.10.1) command must be issued.

Note: For single shot operation, this parameter always assumes a measurement interval of 5 minutes, counting the number of single shots to calculate elapsed time. If single shot measurements are taken more / less frequently than once every 5 minutes, this parameter must be scaled accordingly to achieve the intended period in hours (e.g. for a 10-minute measurement interval, the scaled parameter value is obtained by multiplying the intended period in hours by 0.5).

Write (hexadecimal)	Input parameter: ASC initial period		Response parameter: -		Max. command duration [ms]
	length [bytes]	signal conversion	length [bytes]	signal conversion	
0x2445	3	word[0] = ASC initial period [hours]	-	-	1
Example: write ASC initial period of 76 hours					
Write (hexadecimal)	0x2445 Command	0x004c Initial period 76 hours	0xc1 CRC of 0x004c		

Table 36: set_automatic_self_calibration_initial_period I²C sequence description

3.11.6 get_automatic_self_calibration_initial_period

Write (hexadecimal)	Input parameter: -		Response parameter: ASC initial period		Max. command duration [ms]
	length [bytes]	signal conversion	length [bytes]	signal conversion	
0x2340	-	-	3	ASC initial period [hours] = word[0]	1
Example: read ASC initial period of 76 hours					
Write (hexadecimal)	0x2340 Command				
Wait	1 ms	command execution time			
Response (hexadecimal)	0x004c 76 hours	0xc1 CRC of 0x004c			

Table 37: get_automatic_self_calibration_initial_period I²C sequence description

3.11.7 set_automatic_self_calibration_standard_period

Description: sets the standard period for ASC correction (in hours). By default, the standard period for ASC correction is 156 hours. Allowed values are integer multiples of 4 hours. Note: a value of 0 results in an immediate correction. To save the setting to the EEPROM, the *persist_settings* (see Section 3.10.1) command must be issued.

Note: For single shot operation, this parameter always assumes a measurement interval of 5 minutes, counting the number of single shots to calculate elapsed time. If single shot measurements are taken more / less frequently than once every 5 minutes, this parameter must be scaled accordingly to achieve the intended period in hours (e.g. for a 10-minute measurement interval, the scaled parameter value is obtained by multiplying the intended period in hours by 0.5).

Write (hexadecimal)	Input parameter: ASC standard period		Response parameter: -		Max. command duration [ms]
	length [bytes]	signal conversion	length [bytes]	signal conversion	
0x244e	3	word[0] = ASC standard period [hours]	-	-	1
Example: set automatic self-calibration standard period of 156 hours					
Write (hexadecimal)	0x244e <i>Command</i>	0x009c <i>Standard period</i> 156 hours	0xc5 <i>CRC of 0x009c</i>		

Table 38: set_automatic_self_calibration_standard_period I²C sequence description

3.11.8 get_automatic_self_calibration_standard_period

Write (hexadecimal)	Input parameter: -		Response parameter: ASC standard period		Max. command duration [ms]
	length [bytes]	signal conversion	length [bytes]	signal conversion	
0x234b	-	-	3	word[0] = ASC standard period [hours]	1
Example: read ASC standard period of 156 hours					
Write (hexadecimal)	0x234b <i>Command</i>				
Wait	1 ms	<i>command execution time</i>			
Response (hexadecimal)	0x009c <i>Standard period</i> 156 hours	0xc5 <i>CRC of 0x009c</i>			

Table 39: get_automatic_self_calibration_standard_period I²C sequence description

3.12 Checksum Calculation

The 8-bit CRC checksum transmitted after each data word is generated by a CRC algorithm. Its properties are displayed in **Table 40**. The CRC covers the contents of the two previously transmitted data bytes. To calculate the checksum only these two previously transmitted data bytes are used. Note that command words are not followed by CRC.

Property	Value	Example code (C/C++)
Name	CRC-8	<pre> #define CRC8_POLYNOMIAL 0x31 #define CRC8_INIT 0xff uint8_t sensirion_common_generate_crc(const uint8_t* data, uint16_t count) { uint16_t current_byte; uint8_t crc = CRC8_INIT; uint8_t crc_bit; /* calculates 8-Bit checksum with given polynomial */ for (current_byte = 0; current_byte < count; ++current_byte) { crc ^= (data[current_byte]); for (crc_bit = 8; crc_bit > 0; --crc_bit) { if (crc & 0x80) crc = (crc << 1) ^ CRC8_POLYNOMIAL; else crc = (crc << 1); } } return crc; } </pre>
Width	8 bit	
Protected Data	read and/or write data	
Polynomial	0x31 ($x^8 + x^5 + x^4 + 1$)	
Initialization	0xff	
Reflect input	False	
Reflect output	False	
Final XOR	0x00	
Examples	CRC (0xbeef) = 0x92	

Table 40: I²C CRC properties

4.3 Tape & Reel Package

Figure 5 details the tape and reel package specifications. Reels are 7 inches and 13 inches in diameter for the 60-piece and 600-piece package sizes, respectively.

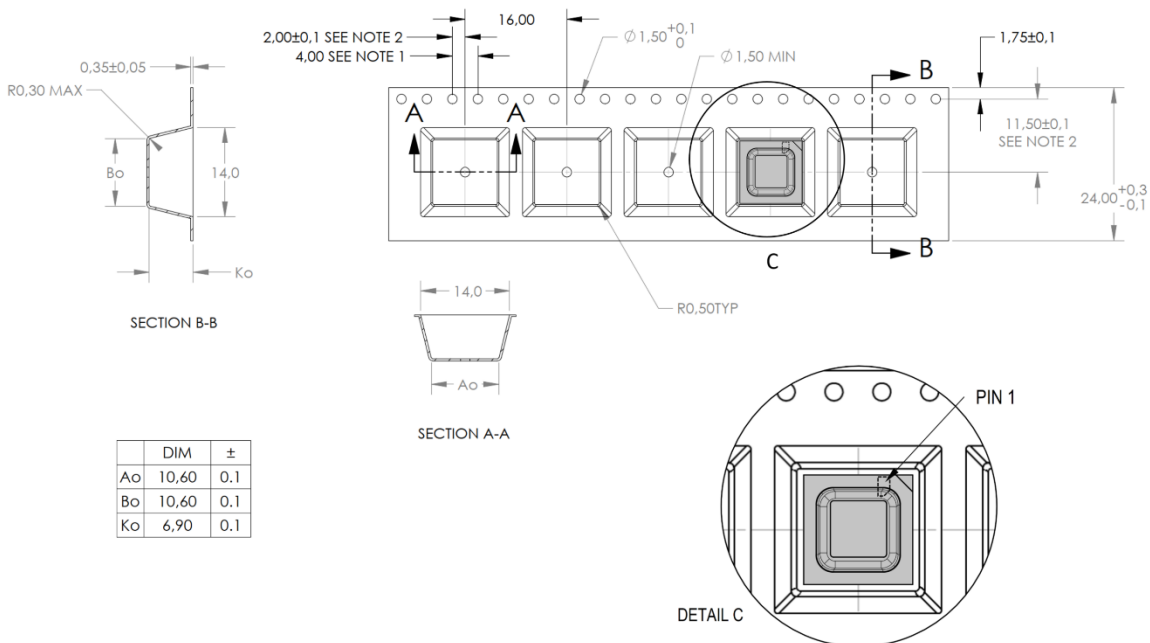

Figure 5: Technical drawing of the packaging tape with sensor orientation in tape. In the drawing, header tape is to the right and trailer tape to the left. All dimensions in millimeters.

4.4 Moisture Sensitivity Level

Sensirion SCD4x sensors must be treated according to Moisture Sensitivity Level 1 (MSL1) as per IPC/JEDEC J-STD-033B1. The manufacturing floor time (out of bag) at the customer's end is not limited under normal factory conditions (≤ 30 °C and 85 %RH). It is recommended to process the sensors within one year of the date of delivery. Exposure to moisture levels or solder reflow temperatures which exceed the limits as stated in this document can result in yield loss and reliability degradation²⁰.

²⁰ More information on SCD4x packing and storage can be found in the user guide "Handling Instructions SCD4x"

4.5 Soldering Instructions

The sensors are designed to withstand a soldering profile based on IPC/JEDEC J-STD-020, with a maximum peak temperature of 245 °C up to 30 sec and Pb-free assembly in IR/Convection reflow ovens. See **Table 41** for more details.

Note that due to the size and shape of the SCD4x sensor, significant temperature differences across the sensor element can occur during reflow soldering. Specifically, the temperature within the sensor cap can be higher than the temperature measured at the pad using usual temperature monitoring methods. Care must be taken that a temperature of 245°C is not exceeded at any time in any part of the sensor.

The SCD4x is not compatible with vapor phase reflow soldering. The dust cover on top of the cap must not be removed or wetted with any liquid. Do not apply extra flux during the reflow soldering nor reflow solder more than once. Do not apply any board wash process step subsequently to the reflow soldering²¹.

Minor temporary accuracy deviations of the CO₂ reading can result from the reflow soldering of the SCD4x. Full sensor accuracy is restored after at most five days after the soldering process, independently of whether the sensor is operated or not.

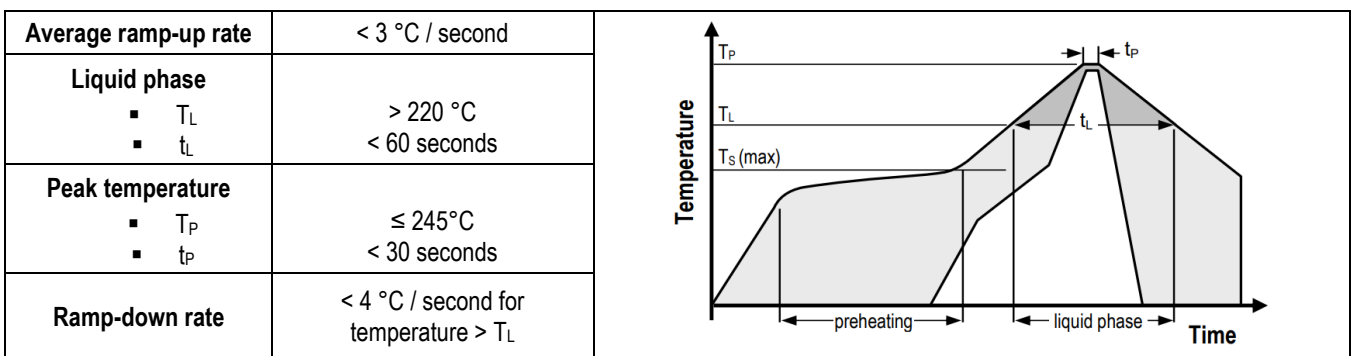

Table 41: Soldering profile parameters

4.6 Traceability and Identification

All SCD4x sensors have a distinct electronic serial number for identification and traceability (see Section 3.10.2). The serial number can be decoded by Sensirion only and allows for tracking through production, calibration, and testing.

All SCD4x sensors include a laser marking on the sidewall of the sensor cap. The laser marking contains the product variant (i.e., SCD40, SCD41 or SCD43) and the product serial number within a data matrix (**Figure 6**).

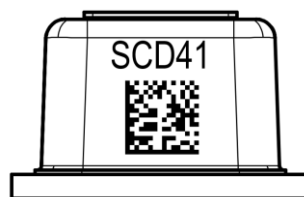

Figure 6: Illustration of a laser marking with product type and data matrix on the sidewall of the sensor cap.

²¹ More information on SCD4x reflow soldering can be found in the user guide "Handling Instructions SCD4x"

5 Ordering Information

Use the part names and product numbers shown in **Table 42** when ordering the SCD4x CO₂ sensor. For the latest product information and local distributors, please visit the Sensirion website.

Part Name	Description	Ordering quantity (pcs)	Product Number
SCD40-D-R1	SCD40 CO2 sensor SMD component as reel, I2C	60 sensors per reel	3.000.496
SCD40-D-R2	SCD40 CO2 sensor SMD component as reel, I2C	600 sensors per reel	3.000.521
SCD41-D-R1	SCD41 CO2 sensor SMD component as reel, I2C	60 sensors per reel	3.000.960
SCD41-D-R2	SCD41 CO2 sensor SMD component as reel, I2C	600 sensors per reel	3.000.961
SCD43-D-R2	SCD43 CO2 sensor SMD component as reel, I2C	600 sensors per reel	3.001.241
SEK-SCD41-Sensor	SEK-SCD41-Sensor set; SCD41 on development board with cables	1	3.000.455
SEK-SCD43-Sensor	SEK-SCD43-Sensor set; SCD43 on development board with cables	1	3.001.244
SEK-SensorBridge	Sensor Bridge to connect SEK-SCD4x-Sensor to computer	1	3.000.124

Table 42: Part names and product numbers for ordering SCD4x

5.1 Historical Information

The parts / product numbers of the SCD4x product family shown in **Table 43** are obsolete.

Period Active	Product Number	Note
Before 01.08.2023	3.000.497	For applicable specifications, see Version 1.3 of the SCD4x Datasheet
Before 01.08.2023	3.000.498	For applicable specifications, see Version 1.3 of the SCD4x Datasheet

Table 43: Obsolete ordering information

6 Revision History

Date	Version	Page(s)	Changes
January 2021	1	all	Initial release
April 2021	1.1	16 - 17	Adjustment max. command time self-test (Section 3.9) and single shot (Section 3.10), minor revisions on other pages
May 2022	1.2	3 12 18 22 all	Clarification on additional sensor accuracy drift (Table 1) Clarification of set_ambient_pressure command description (Section 3.7.5) Addition of power_down and wake_up commands (Section 3.11) Addition of minor temporary accuracy deviation after reflow soldering (Section 4.5) Minor editorial revisions
September 2022	1.3	1,22 All	Correction of hyperlink Minor editorial revisions
February 2023	1.4	3 4 5 6 7 8 10 11 12 17 19 20 22 24 All	Updated SCD41 accuracy values, updated drift parameters and drift conditions (Table 1), correction of tolerance in footnote #2, clarification of footnotes #2, 4 and 5 Clarification of operation mode per average supply current (Table 4), additional information on ESD HBM (Table 5), additional footnote #8, clarification of footnotes #7 and 12 Clarification of recommendations on power supply for sensor operation (Section 2.3) Correction of power-up time and soft reset time, increase of maximum SCL clock frequency to 400 kHz (Section 2.4) Minor editorial revisions for clarification (Section 3.1) Addition of get_ambient_pressure, set_automatic_self_calibration_initial_period, get_automatic_self_calibration_initial_period, set_automatic_self_calibration_standard_period, get_automatic_self_calibration_standard_period and set_automatic_self_calibration_target commands (Table 9), correction of reinit and wake_up execution times (Section 3.4) Addition of recommended temperature offset range, formula correction of signal conversion (Section 3.6.1) Formula correction of signal conversion (Section 3.6.2), addition of valid sensor altitude input values (Section 3.6.3) Addition of valid ambient pressure input values to set_ambient_pressure command (Section 3.6.5) and addition of get_ambient_pressure command (Section 3.6.6) Correction of reinit max. command duration (Section 3.9.5), clarification of typical communication sequence for single shot measurement mode (Section 3.10) Correction of wake_up max. command duration (Section 3.10.4), addition of set_automatic_self_calibration_initial_period (Section 3.10.5) and get_automatic_self_calibration_initial_period commands (Section 3.10.6) Addition of set_automatic_self_calibration_standard_period command (Section 3.10.7) and get_automatic_self_calibration_standard_period command (Section 3.10.8) Additional information on white protection membrane (Section 4.1) Increase of peak reflow soldering temperature to 245°C, clarification of soldering guidance (Section 4.5), addition of information concerning product laser marking (Section 4.6) Minor editorial revisions
July 2023	1.5	4 15 19, 20 22 25 All	Clarified description of supply voltage ripple specification (Section 2, Table 4) Addition of description for get_data_ready_status command (Section 3.8.2) Clarification on ASC availability in power-cycled single shot operation (Section 3.10), Addition of clarification on ASC period parameter scaling for single shot operation (Sections 3.10.5 and 3.10.7) Moved dimensions into Figure 3, removed separate table with dimensions (Section 4.1) Updated product numbers for SCD41, addition of historical ordering information (Section 5) Minor editorial revisions
September 2024	1.6	1 3 4	Updated visuals and product summary, corrected block diagram, added footnotes #1-3 Clarification of default conditions, clarification of conditions for response time specification and description of drift specification (Table 1), clarified measurement mode condition for RH/T response time specification and moved previous footnote #5 into prose text (Sections 1.2 and 1.3), clarification of footnotes #6-8(prev. footnotes 2-4). Changed moisture sensitivity level specification to MSL Level 1 (Section 2.2, Table 5) Clarification of footnote #15 (prev. footnote 12)

		5	Clarification of recommendations on power supply for sensor operation and of I ² C specification (Section 2.3)
		7	Moved Table 8 into separate new sub-section clarifying sensor I ² C address (Section 3.2)
		8	Addition of set_automatic_self_calibration_target, get_automatic_self_calibration_target and get_sensor_variant commands to Table 9 (Section 3.5)
		9	Clarified typical communication sequence description (Section 3.6)
		10	Clarified description of stop_periodic_measurement command (Section 3.6.3)
			Clarified description of on-chip output signal compensation (Section 3.7) and set_temperature_offset command (Section 3.7.1)
		13	Clarified and expanded information on ASC functionality and conditions for use with default parameters (Section 3.8)
		14	Addition of set_automatic_self_calibration_target command (Section 3.8.4)
		15	Addition of get_automatic_self_calibration_target command (Section 3.8.5)
		16	Clarified note on EEPROM lifetime conditions for operation with ASC (Section 3.10.1)
		18	Addition of get_sensor_variant command (Section 3.10.6)
			Addition of note on shortest possible single shot measurement interval, clarified impact of single shot measurement interval on ASC functionality and EEPROM lifetime, removed recommendation to discard initial single shot measurement after power cycle (Section 3.11)
		21	Clarified note on ASC initial period parameter adaption based on single shot measurement interval (Section 3.11.5)
		22	Clarified note on ASC standard period parameter adaption based on single shot measurement interval (Section 3.11.7)
		24	Clarified note on polarity marking of the sensor, updated Figure 3 to add bottom view with respective dimensions (Section 4.1)
			Addition of note on sensor thermal relief hole and respective keep free area, updated Figure 4 for clarity (Section 4.2)
		25	Addition of reel diameters (Section 4.3).
			Updated moisture sensitivity level specification from MSL3 to MSL1, adapted out of bag manufacturing floor time conditions in accordance with MSL1, removed table specifying baking conditions for MSL3 (Section 4.4)
		All	Minor editorial revisions
April 2025	1.7	1	Updated product summary, added product visual for SCD43, Updated & reordered footnotes #1-3, Addition of new footnote #4
		13	Clarified section on ASC functionality (Section 3.8), Added note on pressure/altitude compensation for conducting FRC (Section 3.8.1)
		All	Addition of specifications for SCD43
			Minor editorial revisions and clarifications

Important Notices

Warning, Personal Injury

Do not use this product as safety or emergency stop devices or in any other application where failure of the product could result in personal injury (including death). Do not use this product for applications other than its intended and authorized use. Before installing, handling, using or servicing this product, please consult the data sheet and application notes. Failure to comply with these instructions could result in death or serious injury.

If the Buyer shall purchase or use SENSIRION products for any unintended or unauthorized application, Buyer shall defend, indemnify and hold harmless SENSIRION and its officers, employees, subsidiaries, affiliates and distributors against all claims, costs, damages and expenses, and reasonable attorney fees arising out of, directly or indirectly, any claim of personal injury or death associated with such unintended or unauthorized use, even if SENSIRION is allegedly negligent with respect to the design or the manufacture of the product.

ESD Precautions

The inherent design of this component causes it to be sensitive to electrostatic discharge (ESD). To prevent ESD-induced damage and/or degradation, take customary and statutory ESD precautions when handling this product. See application note "ESD, Latchup and EMC" for more information.

Warranty

SENSIRION solely warrants to the original purchaser of this product for a period of 12 months (one year) from the date of delivery that this product is of the quality, material and workmanship defined in SENSIRION's published specifications of the product. Within such period, if proven to be defective, SENSIRION shall as sole and exclusive remedy, in SENSIRION's discretion, repair this product or send a replacement product, free of charge to the Buyer, provided that:

- notice in writing describing the defects shall be given to SENSIRION within fourteen (14) days after their appearance;
- such defects shall be found, to SENSIRION's reasonable satisfaction, to have arisen from SENSIRION's faulty design, material, or workmanship;
- the defective product shall be returned to SENSIRION's factory at the Buyer's expense; and
- the warranty period for any repaired or replaced product shall be limited to the unexpired portion of the original period.

The Buyer shall at its own expense arrange for any dismantling and reassembly that is necessary to repair or replace the defective product. This warranty does not apply to any equipment which has not been installed or used within the specifications recommended by SENSIRION. EXCEPT FOR THE WARRANTIES EXPRESSLY SET FORTH HEREIN, SENSIRION MAKES NO WARRANTIES, EITHER EXPRESS OR IMPLIED, WITH RESPECT TO THE PRODUCT. ANY AND ALL WARRANTIES, INCLUDING WITHOUT LIMITATION, WARRANTIES OF MERCHANTABILITY OR FITNESS FOR A PARTICULAR PURPOSE, ARE EXPRESSLY EXCLUDED AND DECLINED.

SENSIRION is only liable for defects of this product arising under the conditions of operation provided for in the data sheet and proper use of the goods. SENSIRION explicitly disclaims all warranties, express or implied, if the goods are operated or stored not in accordance with the technical specifications.

SENSIRION does not assume any liability arising out of any application or use of any product or circuit and specifically disclaims any and all liability, including without limitation indirect, consequential, and incidental damages, and loss of profit. No obligation or liability shall arise or grow out of SENSIRION's rendering of technical advice, consulting, or implementation instructions or guidelines. All operating parameters, including without limitation recommended parameters, must be validated for each Buyer's applications by the Buyer's technical experts. Recommended parameters can and do vary in different applications.

SENSIRION reserves the right, without further notice, (i) to change the product specifications and/or the information in this document and (ii) to improve reliability, functions and design of this product.

Headquarters and Subsidiaries

Sensirion AG

Laubisruetistr. 50
CH-8712 Staefa ZH
Switzerland

phone: +41 44 306 40 00
fax: +41 44 306 40 30
info@sensirion.com
www.sensirion.com

Sensirion Taiwan Co. Ltd

phone: +886 2 2218-6779
info@sensirion.com
www.sensirion.com

Sensirion Inc., USA

phone: +1 312 690 5858
info-us@sensirion.com
www.sensirion.com

Sensirion Japan Co. Ltd.

phone: +81 45 270 4506
info-jp@sensirion.com
www.sensirion.com/jp

Sensirion Korea Co. Ltd.

phone: +82 31 337 7700~3
info-kr@sensirion.com
www.sensirion.com/kr

Sensirion China Co. Ltd.

phone: +86 755 8252 1501
info-cn@sensirion.com
www.sensirion.com/cn

To find your local representative, please visit
www.sensirion.com/distributors

Copyright © 2025, by SENSIRION. CMOSens® and PASens® are trademarks of Sensirion. All rights reserved.

Mouser Electronics

Authorized Distributor

Click to View Pricing, Inventory, Delivery & Lifecycle Information:

[Sensirion:](#)

[SEK-SCD43-Sensor](#) [SCD43-D-R2](#)