

15050VA (5920VL)

DC Axial Fan

150X^Φ172X50^L



General Specifications

Motor Protection Auto Restart / Polarity Protection

Insulation Resistance 10MΩ or over with a DC500V Megger
Dielectric Withstand Voltage : AC700V 1s

Allowable Ambient : - 10°C ~ + 70°C (Operating)
Temperature Range - 40°C ~ + 70°C (Storage)
non-condensing environment

Outline

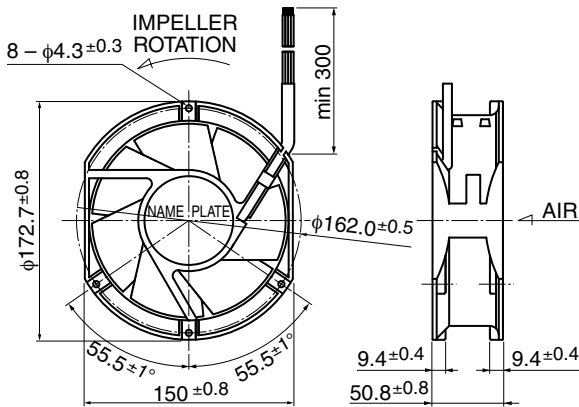

Expected Life

※ Failure Rate: 10% (L10 Life)

25°C 100,000 (Hours)

Panel Out-cuts

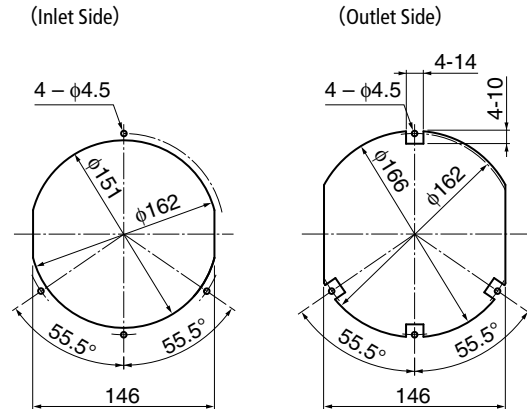

Characteristic Curves

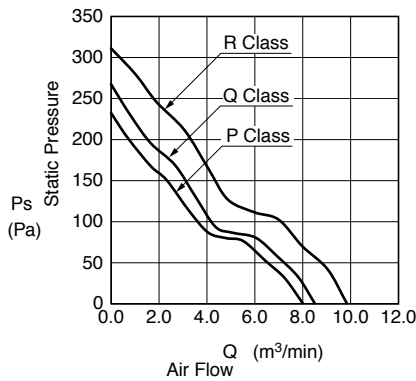

Material

Casing : Aluminum (Black Painting)
Impeller : Plastic (Black) UL94V-0
Bearing : Ball Bearing
Lead Wire : UL10368 AWG22 + : Red, - : Black

Customize service for IP compatible type and Oil-proof type is available for this item. Please contact to our sales representative for more detail.

Specifications

Model	Product Number	Rating Voltage (V)	Operating Voltage (V)	Current (A)*1	Input Power (W)*1	Speed (min-1)*1	Max Air Flow (m ³ /min)*1	(CFM)*1	Max Static Pressure (Pa)	(In H ₂ O)*1	Noise (dB)*1	Mass (g)
15050VA-24M-EA-	00	24	18.0 ~ 26.4	0.80	19.20	3350	7.1	251	165	0.66	58.0	750
15050VA-24N-EA-	00	24	18.0 ~ 26.4	0.90	21.60	3500	7.4	261.0	183	0.74	60.0	
15050VA-24P-EA-	00	24	18.0 ~ 26.4	1.10	26.4	3750	8.0	282	232	0.93	62.0	
15050VA-24Q-EA-	00	24	18.0 ~ 26.4	1.30	31.2	4000	8.5	300	267	1.07	64.0	
15050VA-24R-EA-	00	24	18.0 ~ 26.4	1.80	43.2	4600	9.8	346	312	1.25	68.0	
15050VA-48P-EA-	00	48	38.0 ~ 52.8	0.55	26.4	3750	8.0	282	232	0.93	62.0	
15050VA-48Q-EA-	00	48	38.0 ~ 52.8	0.65	31.2	4000	8.5	300	267	1.07	64.0	
15050VA-48R-EA-	00	48	38.0 ~ 52.8	0.90	43.2	4600	9.8	346	312	1.25	68.0	

Rotation: Counterclockwise as seen from the label side
Airflow Outlet: Label side

*1: Average Values in Free Air

General Specifications

Motor Type: DC Brushless Motor

Motor Protection: Auto Restart/Polarity Protection

Motor withstands reverse connection for positive and negative leads.

Insulation Resistance:

10M Ω or over with a DC500V Megger

Dielectric Withstand Voltage:

AC 700V 1s or 500V 1min

Allowable Ambient Temperature Range:

-10°C ~ +70°C (Operating)

-40°C ~ +70°C (Storage)

(non-condensing environment)

Characteristics Curves

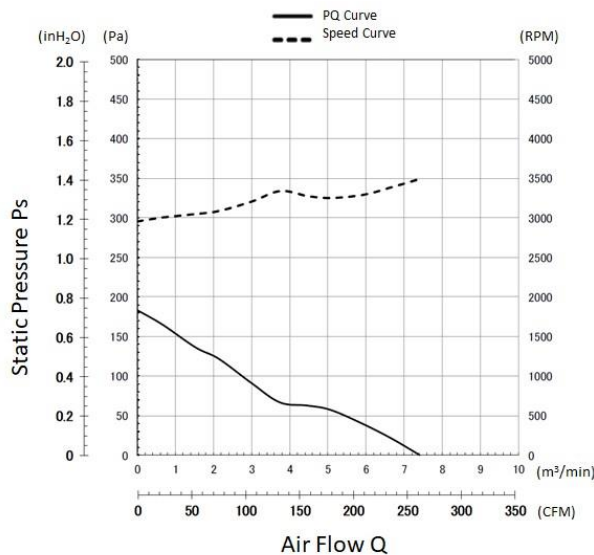

Specifications

MODEL	Rated	Operating	Current		Input Power		Speed	Max.		Max. Static		Noise	Mass
	Voltage	Voltage	Avg	Max	Avg	Max		Air Flow		Pressure			
	(V)	(V)	(A) ^{*1}	(A) ^{*1}	(W) ^{*1}	(W) ^{*1}	(min ⁻¹) ^{*1}	(CFM)	(m ³ /min)	(inH ₂ O)	(Pa)	(dB) ^{*1}	(g)
15050VA-48N-EU-01	48	38.0 ~ 52.8	0.45	0.51	21.60	24.48	3500	261.3	7.40	0.74	183	60.0	750

*1: Values in Free Air

PWM Benefits & Applications

PWM Benefits

- Increased Life Expectancy
- Energy Saving
- Lower Vibration
- Lower Noise
- Current Spike Prevention

PWM Applications

- Routers
- Switches
- Storage
- Data Centers
- Optical Repeaters
- Broadcast Equipment
- Inverters
- UPS
- Battery Chargers
- Fuel Cells
- Industrial Power Supplies
- Welders
- Plasma Cutters
- Instrumentation
- Test Equipment
- Enclosures and more

- Customized fan performances at multiple operating points.
- Peak efficiency resulting in lower total ownership costs.
- Cost effective and better reliability.

Life Expectancy L10

25°C 100,000 Hours

PWM Specifications

PWM CONTROL CONNECTION

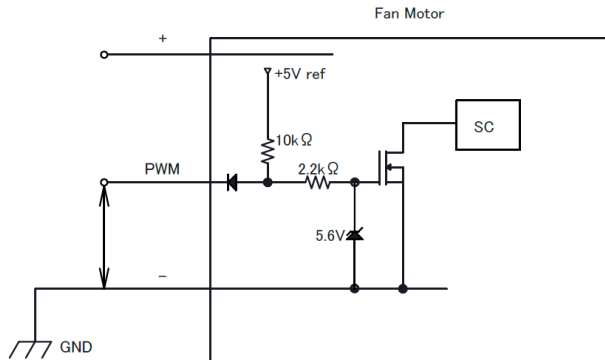

1. PWM Control

- V_{st} = Low Level (0V~0.4V) → Stop (On Duty 0%)
- V_{st} = High Level (4.0V~5.0V) → Full Speed (On Duty 100%)
- V_{st} = Open → Full Speed

2. PWM Duty & PWM Input Pulse

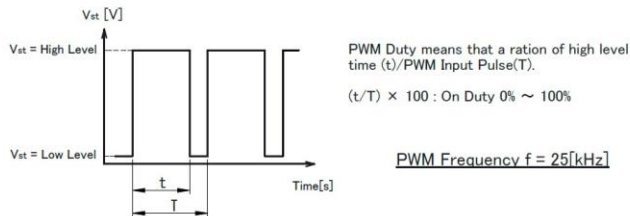

TACHO Specifications

TACHO SIGNAL

1. OUTPUT CIRCUIT : OPEN COLLECTOR
2. SPECIFICATION

$T_a=25^{\circ}\text{C}$
 Absolute Maximum Ratings at $T_a=25^{\circ}\text{C}$
 V_{CE} max : +52.8V
 I_c max : 5mA [$V_{CE}(\text{sat})_{\text{max}} = 2\text{V}$]

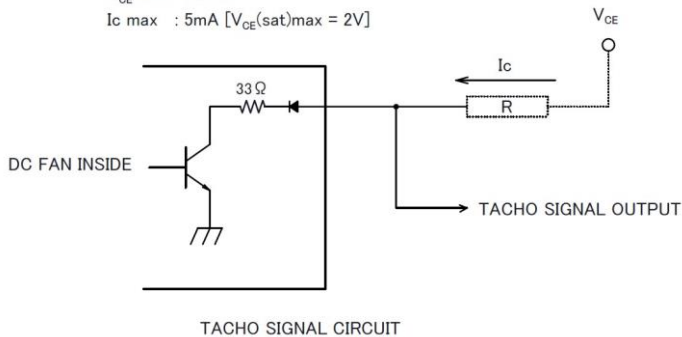

PWM Characteristics Curve

Reference PWM Duty VS Speed
 Conditions: at rating Voltage, $V_{st}=5.0\text{V}$, $f=25\text{kHz}$, $T_a=25^{\circ}\text{C}$

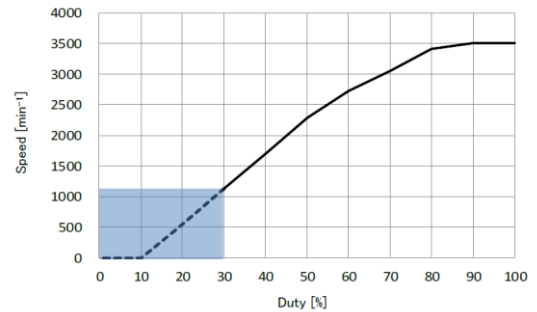

3. The condition for PWM control are as follows.

- When you use this under PWM control, always be sure the motor's operation under practical mounting state.
 Fan motor may not start up caused by PWM control at very low speed condition.
- To run at Rating Voltage.
- Please use the start with Duty 30% or more at 25kHz.
 [At rated voltage input, Ambient temperature 25°C]

3. OUTPUT WAVEFORM : AT RATED VOLTAGE

OUTPUT SIGNAL VOLTAGE

3-1 Case-1

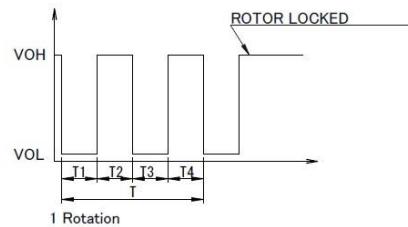

3-2 Case-2

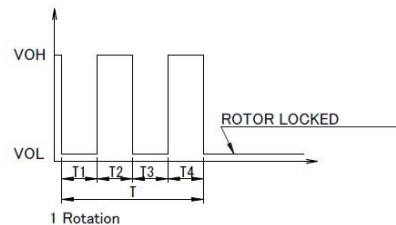

- 1) When the rotor is locked at VOH position of signal, signal keeps VOH position.
- 2) When the rotor is locked at VOL position of signal, signal keeps VOL position.
- 3) $T = T_1 + T_2 + T_3 + T_4 = 60 / m = 1$ rotation
 $m : \text{min}^{-1}$
 Tach Duty Cycle = $50\% \pm 10\%$

Panel Cut-Outs

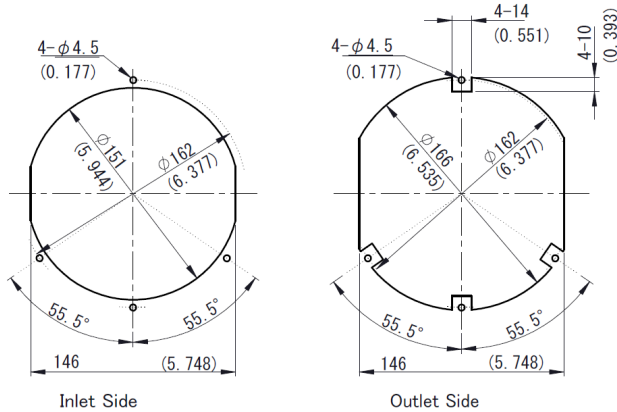

Unit: mm (inch)

Materials

- Casing : Aluminum (Painted Black)
- Impeller : Plastic (Black UL94V-0)
- Bearing : Ball Bearing
- Lead Wire : UL10368 AWG22 and AWG24
 - AWG22:
 - (+) : Red (-) : Black
 - AWG24:
 - PWM : Brown Tach : White

Outline

Name Plate

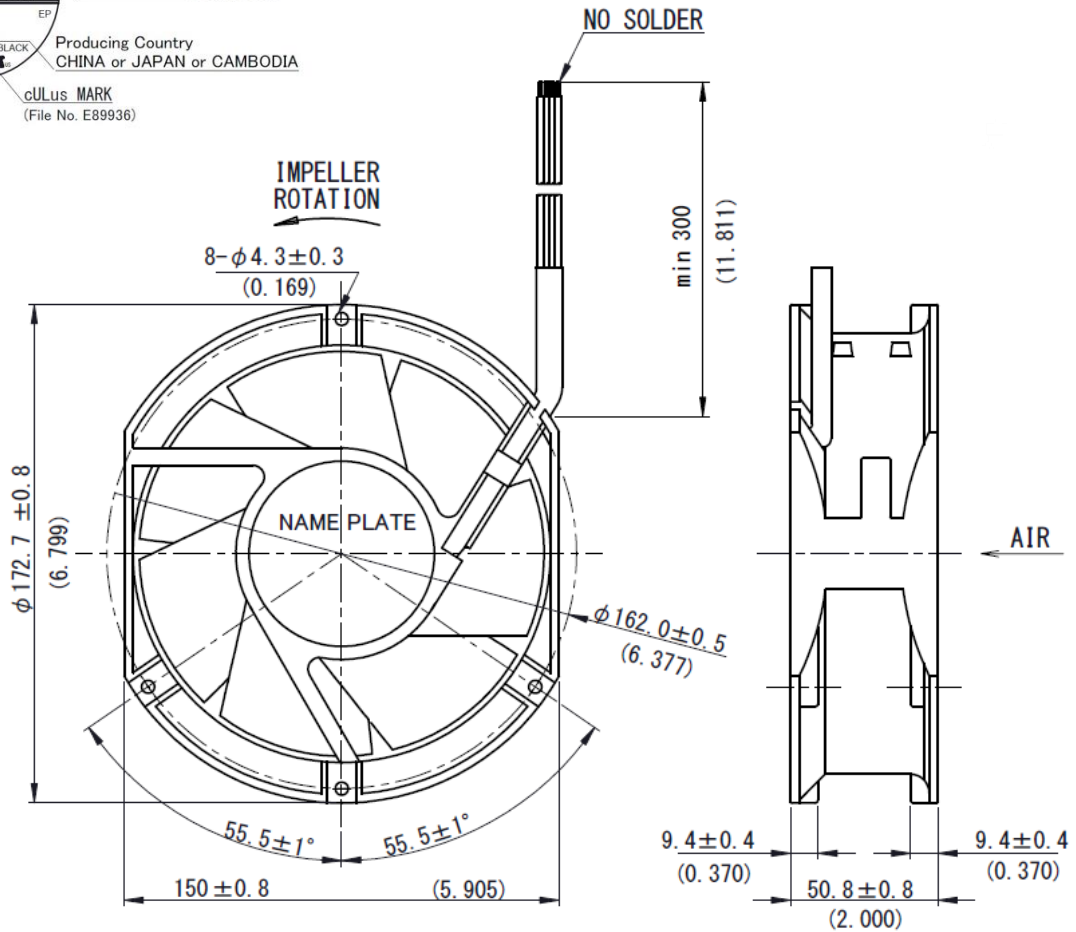
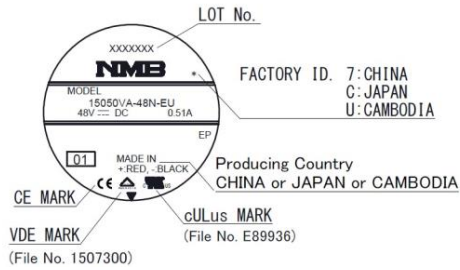

Unit: mm (inch)

General Specifications

Motor Protection:

Auto Restart/Polarity Protection

Insulation Resistance:

10M Ω or over with a DC500V Megger

Dielectric Withstand Voltage: AC 700V 1s

Allowable Ambient Temperature Range:

-10°C ~ +70°C (Operating)

-40°C ~ +70°C (Storage)

IP Code: IP69K

Characteristic Curves

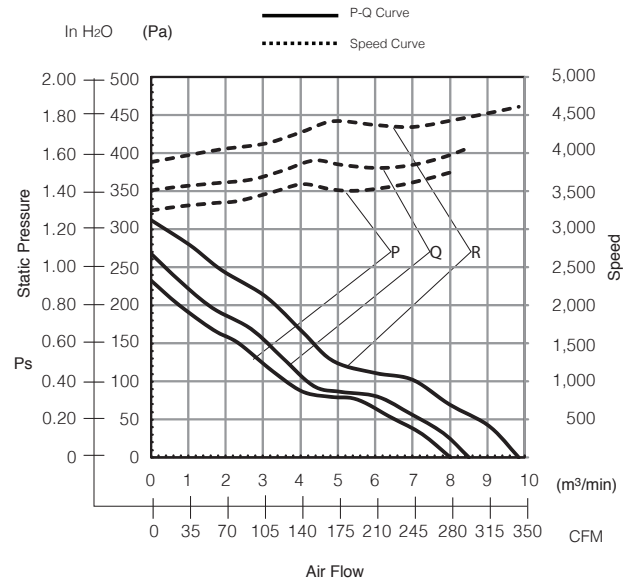

Expected Life

25°C 100,000 Hours (L10)

Material

Casing : Aluminum (Black)

Impeller : Plastic (Black) UL94V-0

Bearing : Ball Bearing

Lead Wire : UL10368, AWG22, +Red, -Black

Outline

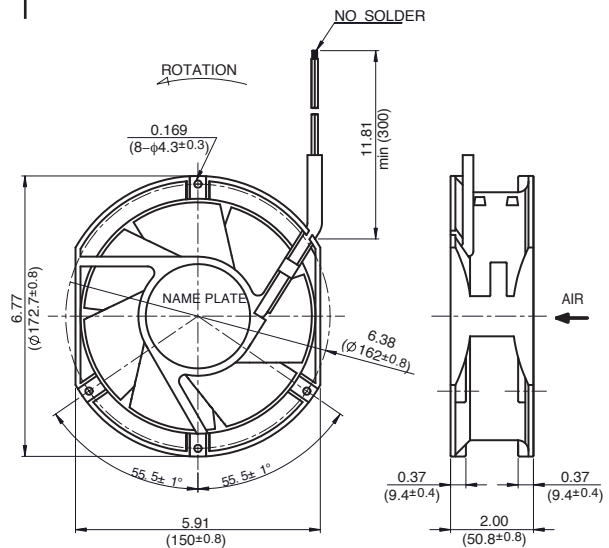

Panel Cut-Outs

Units: inch (mm)

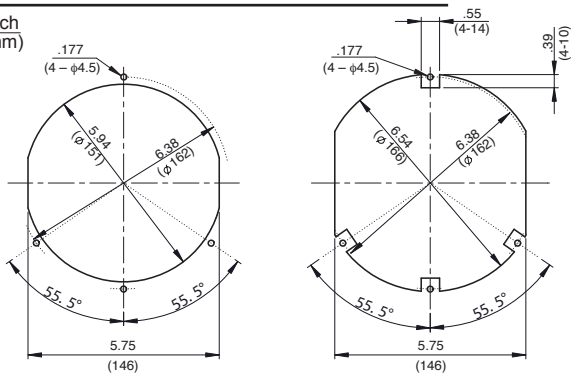

INLET SIDE

OUTLET SIDE

Specifications

MODEL	Rated Voltage	Operating Voltage	Current	Input Power	Speed	Max. Air Flow		Max. Static Pressure		Noise	Mass
	(V)	(V)	(A) ^{*1}	(W) ^{*1}	(min ⁻¹) ^{*1}	CFM ^{*1}	(m ³ /min) ^{*1}	in H ₂ O	(Pa) ^{*1}	(dB) ^{*1}	(g)
15050VA-24P-GA-00	24	18.0 ~ 26.4	1.10	26.4	3750	282.52	8.0	0.93	232.0	62.0	870
15050VA-24Q-GA-00	24	18.0 ~ 26.4	1.30	31.2	4000	300.17	8.5	1.07	267.0	64.0	870
15050VA-24R-GA-00	24	18.0 ~ 26.4	1.80	43.2	4600	346.08	9.8	1.25	312.0	68.0	870
15050VA-48P-GA-00	48	38.0 ~ 52.8	0.55	26.4	3750	282.52	8.0	0.93	232.0	62.0	870
15050VA-48Q-GA-00	48	38.0 ~ 52.8	0.65	31.2	4000	300.17	8.5	1.07	267.0	64.0	870
15050VA-48R-GA-00	48	38.0 ~ 52.8	0.90	43.2	4600	346.08	9.8	1.25	312.0	68.0	870

Rotation: Clockwise

Airflow Outlet: Air Out Over Struts

*1: Average Values in Free Air

Note: PWM/Locked Rotor/Tach Available

Mouser Electronics

Authorized Distributor

Click to View Pricing, Inventory, Delivery & Lifecycle Information:

[NMB Technologies:](#)

[15050VA-48P-EA-00](#) [15050VA-48R-EU-00](#) [15050VA-24N-ET-00](#) [15050VA-24R-EA-00](#) [15050VA-24R-EU-00](#)
[15050VA-48M-EA-00](#) [15050VA-48N-EA-00](#) [15050VA-24N-EA-00](#) [15050VA-48Q-ET-00](#) [15050VA-48R-ET-00](#)
[15050VA-48N-ET-00](#) [15050VA-48N-EL-00](#) [15050VA-24M-ET-00](#) [15050VA-24N-EL-00](#) [15050VA-24M-EA-00](#)
[15050VA-48Q-EL-00](#) [15050VA-24R-EL-00](#) [15050VA-48P-EL-00](#) [15050VA-48M-EL-00](#) [15050VA-24Q-ET-00](#)
[15050VA-24R-ET-00](#) [15050VA-24P-ET-00](#) [15050VA-24P-EL-00](#) [15050VA-48Q-EA-00](#) [15050VA-24L-EA-00](#)
[15050VA-24M-EL-00](#) [15050VA-24L-ET-00](#) [15050VA-24L-EL-00](#) [15050VA-48R-EL-00](#) [15050VA-24Q-EL-00](#)
[15050VA-48P-ET-00](#) [15050VA-48M-ET-00](#)