

4

3

2

1

## MOTOR SPECIFICATIONS:

FRAME SIZE:	NEMA 11	ROTOR INERTIA (g-cm <sup>2</sup> /oz-in <sup>2</sup> ):	12/6.5E-02 NOM
STEP ACCURACY (°):	±0.09	INSULATION CLASS:	B (130°C)
STEP ANGLE (°):	1.8	BEARINGS:	ABEC 3, DOUBLE SHIELDED
INPUT VOLTAGE (VDC):	15 - 30	APPROVALS:	CE, RoHS

## GEARMOTOR SPECIFICATIONS:

TEMP. RISE (°C):	80 MAX	TOTAL WEIGHT (±10g/±0.35oz):	217/7.65
OPERATING AMB. TEMP. RANGE (°C):	0 to +85	RELATIVE HUMIDITY RANGE (%):	90 NON-CONDENSING
STORAGE TEMP. RANGE (°C):	0 to +40		

## GEARHEAD SPECIFICATIONS:

RATIO:	4:1	EFFICIENCY (%):	90
MAX TORQUE CONTINUOUS (Nm/oz-in):	0.5/70.8	BACKLASH (°):	≤1.2
MAX TORQUE (Nm/oz-in):	0.8/113.3	MAX RADIAL LOAD (N/lbf):	≤20/4.49
MAX INPUT SPEED (RPM):	6000	MAX AXIAL LOAD (N/lbf):	≤20/4.49

## NOTES, UNLESS OTHER WISE SPECIFIED:

- THIS ASSEMBLY IS MANUFACTURED IN COMPLIANCE WITH THE CURRENT EU RoHS DIRECTIVE.
- ALL SPECIFICATIONS AND OPERATING INSTRUCTIONS CAN BE FOUND AT APPLIED-MOTION.COM.

## REVISIONS

ECO #	REV.	DESCRIPTION	DATE	APPROVED
7935	A	INITIAL RELEASE	7/2/18	J. KORDIK
8161	B	REVISE FROM L1 TO L2	3/8/19	J. KORDIK
8758	C	REDRAWN IN SOLIDWORKS	4/18/22	L. LIU

 <b>Applied Motion Products</b> <small>A MOONS' COMPANY</small> <b>PROPRIETARY AND CONFIDENTIAL</b> THE INFORMATION CONTAINED IN THIS DRAWING IS THE SOLE PROPERTY OF APPLIED MOTION PRODUCTS. ANY REPRODUCTION IN PART OR AS A WHOLE WITHOUT THE WRITTEN PERMISSION OF APPLIED MOTION PRODUCTS IS PROHIBITED.	THIRD ANGLE PROJECTION	NAME	DATE	<b>TITLE:</b> <b>INTEGRATED STEP-SERVO MOTOR WITH GEARHEAD</b>	
	UNLESS OTHERWISE SPECIFIED: DIMENSIONS ARE IN MILLIMETERS	DRAWN	Y. LAPNET		4/18/22
	TOLERANCES: - ANGULAR: ± 0.5 - ONE DECIMAL PLACE: ± 0.25 - TWO DECIMAL PLACES: ± 0.13	PRE.CHECK			
		PRE.APPROVAL			
MATERIAL	FIN.CHECK	C. BREUNINGER	4/18/22	SIZE	
FINISH	SAP: 4696351005847			DWG. NO.	
DO NOT SCALE DRAWING	ALT DWG. NO.:			<b>B</b> TSM11Q-2HM-G004	
	ALT SAP:			REV	
				<b>C</b>	
				SCALE: 2:1	
				SHEET 1 OF 2	

4

3

2

1

4

3

2

1

B

B

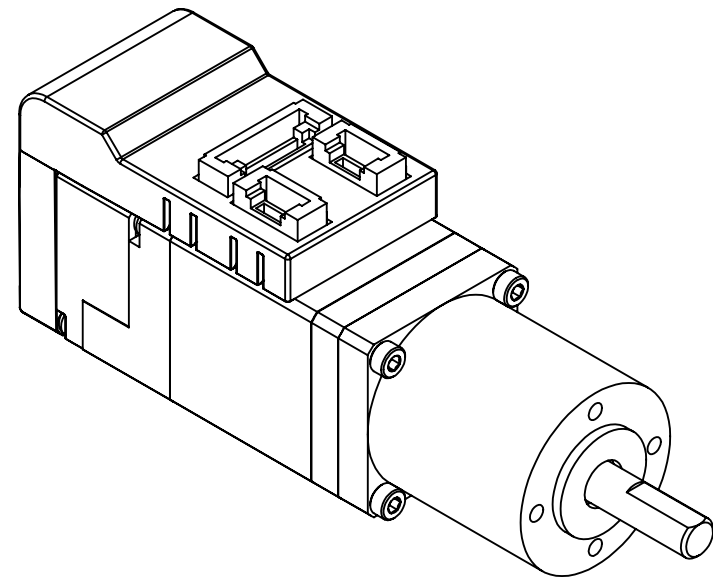
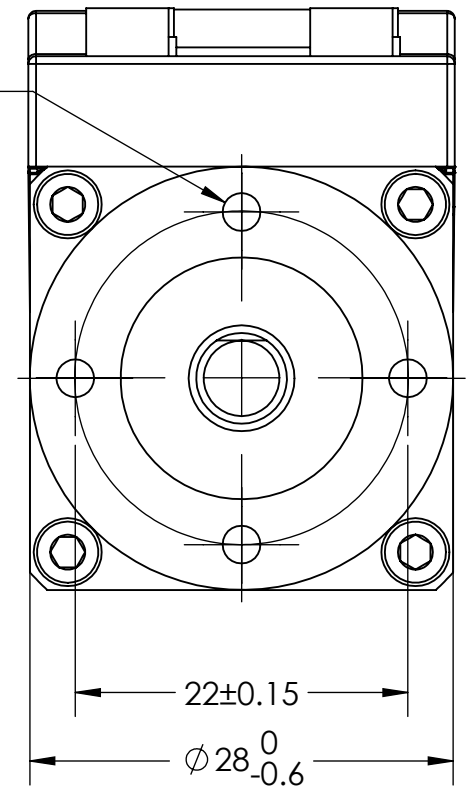
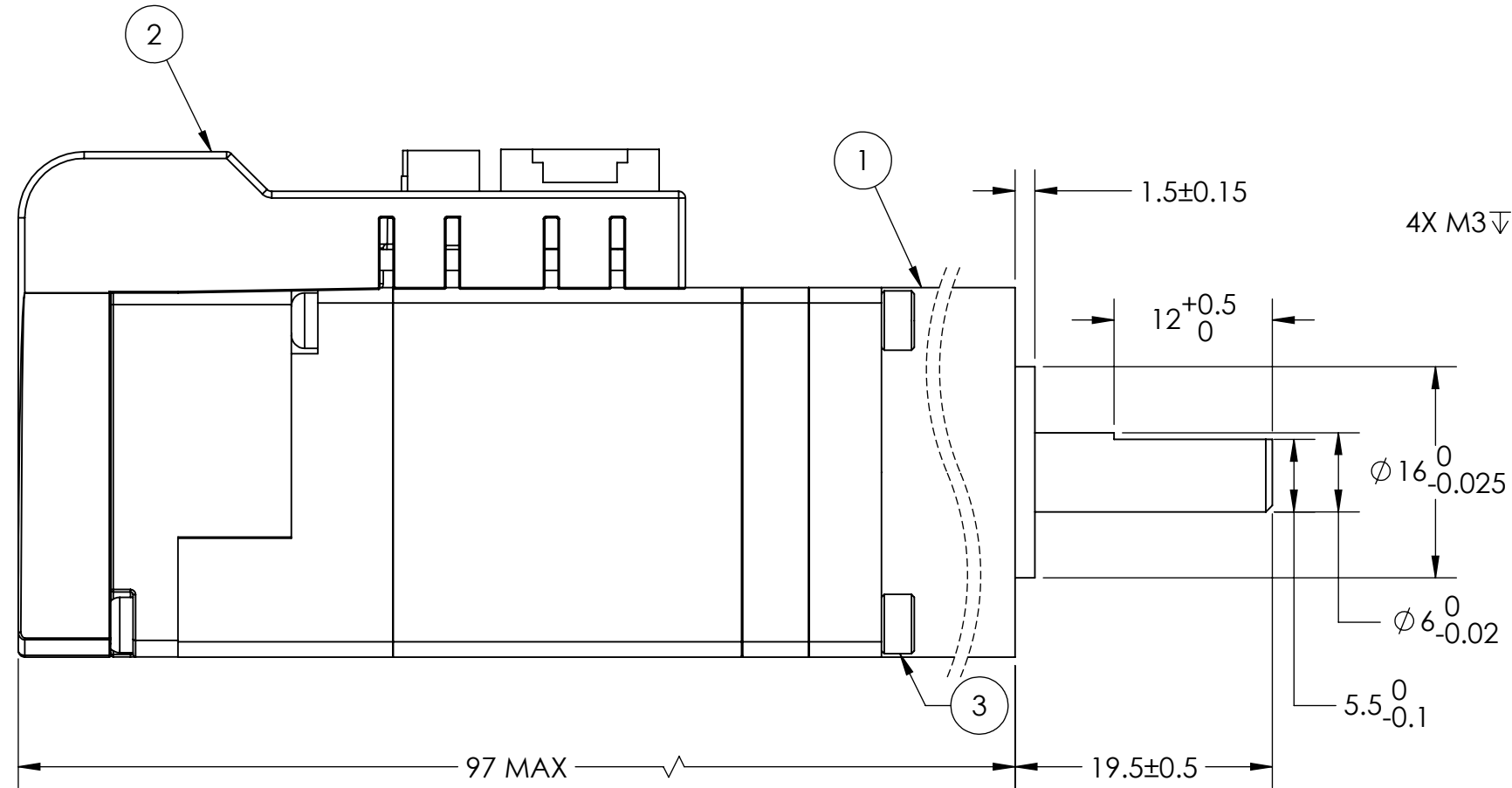
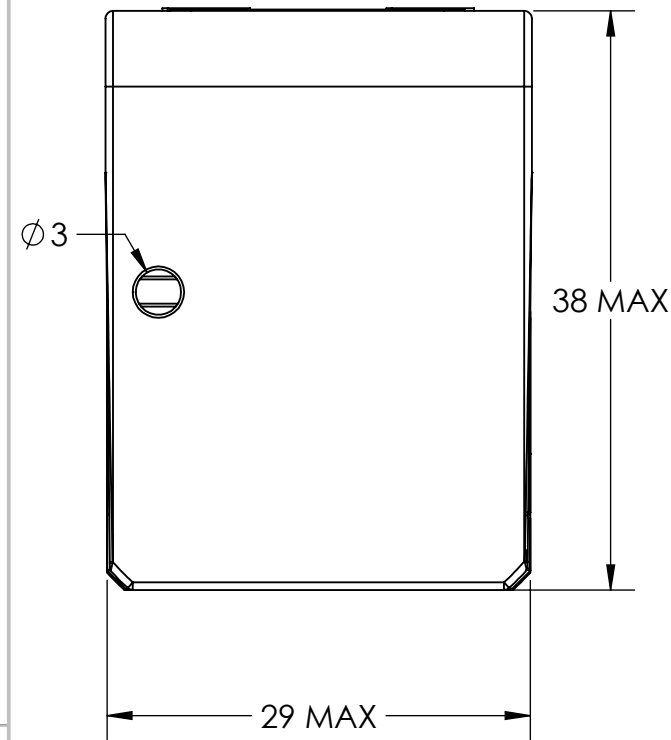

ITEM NO.	SAP PART NUMBER	PART NUMBER	DESCRIPTION	QTY.
1	4332401001498	28PH004.00-L2	PH GEARHEAD	1
2	4696351003106	TSM11Q-2RM-H01	STEP-SERVO MOTOR	1
3	4294404001453	91292A012 OR EQUIVALENT	M2.5X8MM STAINLESS STEEL SOCKET HEAD SCREW	4

**GEARHEAD MATERIALS:**

GEARTRAIN:	Y100 (1144) STEEL
HOUSING:	304 STAINLESS STEEL
INPUT/OUTPUT FLANGE:	LY12 ALUMINUM
OUTPUT SHAFT:	40Cr STEEL
PINION:	Y100 (1144) STEEL

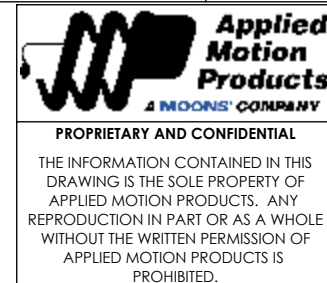

THIRD ANGLE PROJECTION		NAME	DATE
UNLESS OTHERWISE SPECIFIED: DIMENSIONS ARE IN MILLIMETERS		DRAWN	Y. LAPNET
TOLERANCES:		PRE.CHECK	
- ANGULAR: ± 0.5		PRE.APPROVAL	
- ONE DECIMAL PLACE: ± 0.25		FIN.CHECK	C. BREUNINGER
- TWO DECIMAL PLACES: ± 0.13			4/18/22
MATERIAL	SAP: 4696351005847		
FINISH	ALT DWG. NO.:		
DO NOT SCALE DRAWING	ALT SAP:		

TITLE:		
INTEGRATED STEP-SERVO MOTOR WITH GEARHEAD		
SIZE	DWG. NO.	REV
<b>B</b>	TSM11Q-2HM-G004	<b>C</b>
SCALE: 2:1		SHEET 2 OF 2

4

3

2

1

A

A

# Mouser Electronics

Authorized Distributor

Click to View Pricing, Inventory, Delivery & Lifecycle Information:

[Applied Motion:](#)

[TSM11Q-2HM-G004](#)